



## High-Temperature Monobloc Air-to-Water Heat Pumps with Integrated Hydronic Module

PRO-DIALOG +



Quality and Environment  
Management Systems  
Approval



**AQUASNAP**  
Heating

# 61AF 022-105

**Nominal heating capacity 22-105 kW**

The new generation of Aquasnap high-temperature heat pumps was designed for commercial applications such as the heating of offices, apartments and hotels as well as domestic hot water production in new and refurbished buildings.

### Features

The main features of this product range are:

- **Energy savings**  
The 61AF range is certified to the Eurovent energy efficiency class A with a coefficient of performance (COP) of over 4. This complies with the COP required by the Ecolabel certification.
- **Ease-of-installation**  
The high-temperature Aquasnap heat pumps incorporate a hydronic module with a multi-speed pump, as standard. An optional hydronic module with a variable-speed pump that automatically adapts to the system requirements is also available.
- **Easy integration**  
The low noise levels of the 61AF heat pump and its very compact chassis reduce the noise disturbance from the unit.
- **Application flexibility**  
The operating range allows outside temperatures down to -20°C and leaving water temperatures up to 65°C for domestic hot water applications.

- **Availability**
  - Intelligent unit control permits unit operation in extreme conditions, minimising unit shut-down times.
  - Hot water production at 65°C is available continuously.

Carrier quality is your guarantee for the safety and durability of the installation.

The new generation of high-temperature heat pumps incorporates the latest technological features:

- scroll compressors with vapour injection
- low-noise fans made of a composite material
- auto-adaptative microprocessor control
- electronic expansion valve
- multi-speed pump.

The high-temperature Aquasnap heat pumps can be equipped with a hydronic module that is integrated into the heat pump chassis, limiting the installation to straightforward operations like the wiring and the connection of the hot water supply and return piping.

## Quiet operation

- Compressors
  - Low-noise scroll compressors with low vibration level.
  - The compressor assembly is installed on an independent chassis and supported by anti-vibration mountings.
  - Dynamic suction and discharge piping supports, minimising vibration transmission (Carrier patent).
- Evaporator section
  - Vertical evaporator coils
  - Protection grilles on anti-vibration mountings to protect the heat exchanger against possible shocks.
  - Latest-generation low-noise Flying Bird fans, made of a composite material (Carrier patent), are now even quieter and do not generate intrusive low-frequency noise.
  - Rigid fan installation for reduced start-up noise (Carrier patent).

## Easy and fast installation

- Integrated hydronic module (option)
  - Multi-speed centrifugal water pump, based on the pressure loss of the hydronic installation.
  - Water filter protects the water pump against circulating debris.
  - Pump protected against cavitation by a pressure transducer that measures the entering water pressure.
  - Overpressure valve, set to 4 bar.
  - Thermal insulation and frost protection down to -20°C, using an electric resistance heater (see table of options).
- Physical features
  - The unit has a small footprint and a low height (1329 mm) allowing it to blend in with any architectural styles.
  - The unit is enclosed by easily removable panels, covering all components (except condensers and fans).
- Simplified electrical connections
  - Single power supply point without neutral.
  - Main disconnect switch with high trip capacity.
  - Transformer for safe 24 V control circuit supply included.
- Fast commissioning
  - Systematic factory operation test before shipment.
  - Quick-test function for step-by-step verification of the instruments, electrical components and motors.

## Economical operation

- Increased energy efficiency
  - The exceptional energy efficiency level (COP) of the high-temperature Aquasnap heat pumps in the heating mode is the result of a long qualification and optimisation process.
  - The electronic expansion device (EXV) allows operation at a lower condensing pressure (COP optimisation).
  - Dynamic superheat management for better utilisation of the condenser surface.
- Reduced maintenance costs
  - Maintenance-free scroll compressors with vapour injection.
  - Pro-Dialog+ control offers fast diagnosis of possible incidents and their history.

## Environmental care

- Ozone-friendly R-407C refrigerant
  - Chlorine-free refrigerant of the HFC group with zero ozone depletion potential.
  - Very efficient - ensures an increased energy efficiency ratio (COP).
- Leak-tight refrigerant circuit
  - Brazed refrigerant connections for increased leak-tightness.
  - Reduction of leaks due to elimination of capillary tubes (TXVs).
  - Verification of pressure transducers and temperature sensors without transferring refrigerant charge.



## Superior reliability

- State-of-the-art concept
  - Cooperation with specialist laboratories and use of limit simulation tools (finite element calculations) for the design of the critical components, e.g. motor supports, suction/discharge piping etc.
- Auto-adaptive control
  - Control algorithm prevents excessive compressor cycling and permits reduction of the water quantity in the hydronic circuit (Carrier patent).
- Exceptional endurance tests
  - Corrosion resistance tests in salt mist in the laboratory.
  - Accelerated ageing test on components that are submitted to continuous operation: compressor piping, fan supports.
  - Transport simulation test in the laboratory on a vibrating table.

## Pro-Dialog+ control

Pro-Dialog+ combines intelligence with operating simplicity. The control constantly monitors all machine parameters and precisely manages the operation of compressors, expansion devices, fans and of the condenser water pump for optimum energy efficiency.

- Energy management
  - Seven-day internal time schedule clock; permits unit on/off control and operation at a second set point.
  - Set point reset based on the outside air temperature or the return water temperature or on the water heat exchanger delta T.
  - Master/slave control of two heat pumps operating in parallel with operating time equalisation and automatic change-over in case of a unit fault (option).
  - Start/stop based on the outside air temperature.
- Ease-of-use
  - The new backlit LCD interface includes a manual control potentiometer to ensure legibility under any lighting conditions.
  - The information is displayed clearly in English, French, German, Italian and Spanish (for other languages please consult Carrier).
  - The Pro-Dialog+ navigation uses intuitive tree-structure menus, similar to the Internet browsers. They are user-friendly and permit quick access to the principal operating parameters: number of compressors operating, suction/discharge pressure, compressor operating hours, set point, air temperature, entering/leaving water temperature.
  - As standard the unit includes a board for the control of a boiler and four electric resistance heater stages.

## Pro-Dialog+ operator interface



## Remote operating mode with volt-free contacts (standard)

A simple two-wire communication bus between the RS485 port of the Aquasnap high-temperature heat pumps and the Carrier Comfort Network offers multiple remote control, monitoring and diagnostic possibilities.

Carrier offers a vast choice of control products, specially designed to control, manage and supervise the operation of a heating system. Please consult your Carrier representative for more information on these products.

- Start/stop: opening of this contact will shut down the heat pump.
- Dual set point: closing of this contact activates a second heating set point (example: unoccupied mode).
- Demand limit: closing of this contact limits the maximum heat pump capacity to a predefined value.
- User safety: this contact is connected in series with the water flow switch and can be used for any customer safety loop.
- Water pump control.
- Alert indication: this volt-free contact indicates the presence of a minor fault.
- Alarm indication: this volt-free contact indicates the presence of a major fault that has led to the shut-down of the refrigerant circuit.

## Remote interface (accessory)

This accessory includes a box that can be mounted inside the building. The power supply is provided via a 220 V/24 V transformer supplied. This interface allows access to the same menus as the unit interface and can be installed up to 300 m from the 61AF unit.

## Flying Bird IV fan

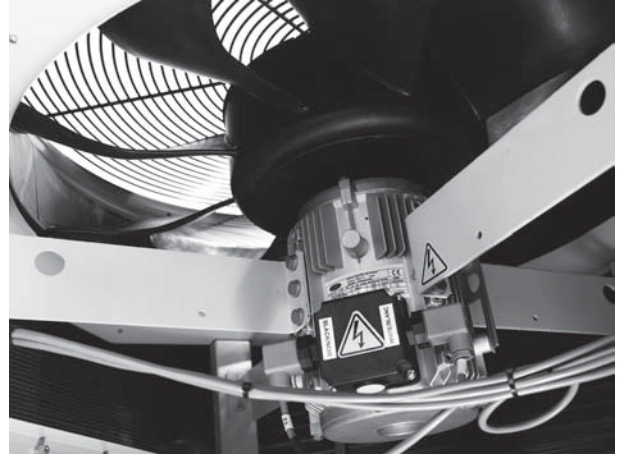

# Options and accessories

Options	No.	Description	Advantages	Use
Anti-corrosion protection, traditional coils	3A	Fins made of pre-treated aluminium (polyurethane or epoxy)	Improved corrosion resistance, recommended for marine environments	61AF 022-105
Ductable version	11	Discharge ducting - max. 100 Pa	Enhances unit adjustment during installation (e.g. under a roof)	61AF 022-105
Low noise level	15	Acoustic compressor enclosure	Noise emission reduction	61AF 022-105
Low noise level	15LS	Acoustic compressor enclosure and fan speed reduction, when ambient air temperature is above 20°C.	Noise emission reduction	61AF 022-105
Soft starter	25	Electronic compressor starter	Reduced compressor start-up current	61AF 022-105
Frost protection down to -20°C	42	Electric heater on the hydronic module (option 116)	Hydronic module frost protection at low outside temperature	61AF 022-105 with option 116F
Low-pressure single-pump hydronic module	116F	See hydronic module chapter	Easy and fast installation	61AF 022-105
JBus gateway	148B	Two-directional communications board, complies with JBus protocol	Easy connection by communication bus to a building management system	61AF 022-105
BacNet gateway	148C	Two-directional communications board, complies with BacNet protocol	Easy connection by communication bus to a building management system	61AF 022-105
LonTalk gateway	148D	Two-directional communications board, complies with LonTalk protocol	Easy connection by communication bus to a building management system	61AF 022-105
Heating system control*	157	Additional remotely installed control box, allows control of the various heating system components	Allows control of pre-configured heating systems	61AF 022-105
Water screw connection between the customer's condenser and the unit	265	Victaulic screw connection at the condenser (standard on sizes 022-030)	Permits customer connections to be screwed to the unit	61AF 035-055
Welded water connection between the customer's condenser and the unit	267	Welded Victaulic connection	Permits customer connections to be welded to the unit	61AF 035-055
Accessories		Description	Advantages	Use
Remote user interface		Remotely installed user interface (via communication bus).	Remote heat pump control up to 300 m	61AF 022-105
JBus gateway communication		Two-directional communications board, complies with JBus protocol	Connection by communication bus to a building management system	61AF 022-105
BacNet gateway communication		Two-directional communications board, complies with BacNet protocol	Connection by communication bus to a building management system	61AF 022-105
LonTalk gateway communication		Two-directional communications board, complies with LonTalk protocol	Connection by communication bus to a building management system	61AF 022-105
Twinning (lead-lag kit)		Unit equipped with an additional field-installed leaving water temperature sensor, allowing master/slave operation of two units connected in parallel	Operation of two units connected in parallel with operating time equalisation	61AF 022-105

\* Option available in 2011.

## Electrical data and operating conditions notes:

- 61AF 022-105 units have a single power connection point located immediately upstream of the main disconnect switch.
- The control box includes the following standard features:
  - a main disconnect switch,
  - starter and motor protection devices for the compressor, the fan and the pump,
  - the control devices.
- Field connections: All connections to the system and the electrical installations must be in full accordance with all applicable local codes.
- The Carrier 61AF units are designed and built to ensure conformance with these codes. The recommendations of European standard EN 60204-1 (machine safety - electrical machine components - part 1: general regulations - corresponds to IEC 60204-1) are specifically taken into account, when designing the electrical equipment.

## Notes:

- Generally the recommendations of IEC 60364 are accepted as compliance with the requirements of the installation directives. Conformance with EN 60204-1 is the best means of ensuring compliance with the Machinery Directive § 1.5.1.
- Annex B of EN 60204-1 describes the electrical characteristics used for the operation of the machines.

- The operating environment for the 61AF units is specified below:
  - Environment\* - Environment as classified in EN 60721 (corresponds to IEC 60721):
    - outdoor installation\*
    - ambient temperature range: -20°C to +40°C, class 4K4H
    - altitude: ≤ 2000 m
    - presence of hard solids, class 4S2 (no significant dust present)
    - presence of corrosive and polluting substances, class 4C2 (negligible)
  - Power supply frequency variation: ± 2 Hz.
  - The neutral (N) conductor must not be connected directly to the unit (if necessary use a transformer).
  - Overcurrent protection of the power supply conductors is not provided with the unit.
  - The factory-installed disconnect switch is of a type suitable for power interruption in accordance with EN 60947-3 (corresponds to IEC 60947-3)
  - The units are designed for connection to TN networks (IEC 60364). For IT networks the earth connection must not be at the network earth. Provide a local earth, consult competent local organisations to complete the electrical installation.

**Caution: If particular aspects of an actual installation do not conform to the conditions described above, or if there are other conditions which should be considered, always contact your local Carrier representative.**

- \* The required protection level for this class is IP43BW (according to reference document IEC 60529). All 61AF units are protected to IP44CW and fulfil this protection condition.

# Physical data

61AF		022	030	035	045	055	075	105
<b>Nominal heating capacity*</b>	kW	20.8	25.7	32.2	43.6	52.2	66.7	102
Power input	kW	5.8	7.3	9.2	11.8	14	19.4	28.1
Coefficient of performance (COP)	kW/kW	3.6	3.5	3.5	3.7	3.7	3.4	3.6
Eurovent class, heating		A	A	A	A	A	A	A
<b>Nominal heating capacity**</b>	kW	21.2	26.1	32.8	43.8	52.8	64.7	102
Power input	kW	4.9	6.1	7.8	9.9	11.9	16.1	23.6
Coefficient of performance (COP)	kW/kW	4.3	4.3	4.2	4.4	4.4	4.0	4.3
Eurovent class, heating		A	A	A	A	A	B	A
<b>Operating weight***</b>								
Standard unit (without hydronic kit)	kg	343	396	421	509	533	900	1020
Standard unit (plus hydronic module option)	kg	349	403	436	524	549	926	1046
<b>Sound levels</b>								
Sound power level 10 <sup>-12</sup> W****	dB(A)	81	82	83	83	84	84	85
Sound pressure level at 10 m†	dB(A)	50	51	51	51	53	52	53
<b>Compressor</b>		Hermetic scroll 48.3 r/s						
Quantity		1	1	1	1	1	2	2
Number of capacity stages		1	1	1	1	1	2	2
<b>Refrigerant</b>		R-407C						
Charge	kg	8.0	8.8	9.7	10.0	13.2	22.0	26.5
<b>Capacity control</b>		Pro-Dialog+						
Minimum capacity	%	100	100	100	100	100	50	50
<b>Condenser</b>		Direct-expansion plate heat exchanger						
Water volume	l	4.9	6.4	8.2	9.6	12.1	16.4	22.7
Max. water-side operating pressure without hydronic module	kPa	1000	1000	1000	1000	1000	1000	1000
Max. water-side operating pressure with hydronic module	kPa	400	400	400	400	400	400	400
<b>Fan</b>		Axial with rotating shroud, Flying Bird IV						
Quantity		1	1	1	1	1	2	2
Total air flow (high speed)	l/s	3800	3800	3800	3800	3800	7600	7600
Speed	r/s	12	12	12	12	12	12	12
<b>Evaporator</b>		Grooved copper tubes and aluminium fins						
<b>Hydronic module (option 116)</b>		Pump, Victaulic screen filter, safety valve, purge valves (water and air), cavitation pressure sensor						
Three-speed single pump		Pump, Victaulic screen filter, safety valve, purge valves (water and air), cavitation pressure sensor						
<b>Water connections with/without hydronic module</b>		Victaulic						
Connections††	inch	1-1/4	1-1/4	1-1/2	1-1/2	1-1/2	2	2
Outside diameter	mm	42.4	42.4	48.3	48.3	48.3	60.3	60.3
<b>Chassis paint colour</b>		Colour code: RAL 7035						

\* Standardised Eurovent conditions: entering leaving condenser water temperature = 40°C/45°C, outside air temperature db/wb = 7°C/6°C

\*\* Standardised Eurovent conditions: entering leaving condenser water temperature = 30°C/35°C, outside air temperature db/wb = 7°C/6°C

\*\*\* Weight shown is a guideline only. To find out the unit refrigerant charge, please refer to the unit nameplate.

\*\*\*\* In accordance with ISO 9614-1 and certified by Eurovent. The values have been rounded and are for information only and not contractually binding

† For information, calculated from the sound power level Lw(A)

†† Units 61AF 022 and 61AF 030 include two sleeves for a 1-1/4" Victaulic to 1-1/4" screw connection as standard.

# Electrical data

61AF - standard unit (without hydronic module)		022	030	035	045	055	075	105
<b>Power circuit</b>								
Nominal power supply	V-ph-Hz	400-3-50						
Voltage range	V	360-440						
<b>Control circuit supply</b>		24 V, via internal transformer						
<b>Maximum start-up current (Un)*</b>								
Standard unit	A	104.6	102.6	131.0	171.0	191.0	154.5	221.5
Unit with electronic starter option	A	56.1	55.1	70.0	90.8	101.2	101.5	142.5
<b>Unit power factor at maximum capacity**</b>		0.82						
<b>Maximum unit power input**</b>	kW	8.7	11.6	12.9	14.6	16.8	25.8	33.7
<b>Nominal unit current draw***</b>	A	14.3	16.9	20.2	23.2	27.9	39.7	55.1
<b>Maximum unit current draw (Un)****</b>	A	16.1	21.3	24.1	27.1	31.1	47.5	61.5
<b>Maximum unit current draw (Un-10%)†</b>	A	21.1	28.4	32.2	36.4	42.0	63.7	83.3
<b>Customer-side unit power reserve</b>		Customer reserve at the 24 V control power circuit						
<b>Short-circuit stability and protection</b>		See table on the next page						

\* Maximum instantaneous start-up current (maximum operating current of the compressor + fan current + locked rotor current of the compressor).

\*\* Power input, compressor and fan, at the unit operating limits (saturated suction temperature 10°C, saturated condensing temperature 65°C) and nominal voltage of 400 V (data given on the unit nameplate).

\*\*\* Standardised Eurovent conditions: condenser entering/leaving water temperature = 40°C/45°C, outside air temperature db/wb = 7°C/6°C.

\*\*\*\* Maximum unit operating current at maximum unit power input and 400 V (values given on the unit nameplate).

† Maximum unit operating current at maximum unit power input and 360 V.

# Short-circuit stability current, main disconnect without fuse (TN system\*)

61AF - standard unit (main disconnect switch)		022	030	035	045	055	075	105
<b>Value with unspecified upstream protection</b>								
Short-term current at 1 s (I <sub>sw</sub> )	kA rms	0.6	0.6	0.6	1.26	1.26	1.26	2
Admissible peak current (I <sub>pk</sub> )	kA pk	4.5	4.5	4.5	6	6	6	10
<b>Maximum value with upstream protection by Siemens circuit breaker</b>								
Conditional short-circuit current (I <sub>cc</sub> )	kA rms	5.4	7	7	7.7	7.7	6.1	10
Siemens circuit breaker - Compact range		32	40	40	50	63	80	100
Reference number**		5SY6332-7	5SY6340-7	5SY6340-7	5SY4350-7	5SY4363-8	5SP4380-7	5SP4391-7
<b>Maximum value with upstream protection by fuses (gL/gG)</b>								
Conditional short-circuit current (I <sub>cc</sub> )	kA rms	17	50	50	50	50	14.5	22
Siemens fuse (gL/gG)		40	40	40	63	63	80	125

\* Earthing system type

\*\* If another current limitation protection system is used, its time-current and thermal constraint (I<sup>2</sup>t) trip characteristics must be at least equivalent to those of the recommended Siemens circuit breaker. Contact your nearest Carrier office.  
The short-circuit stability current values above are in accordance with the TN system.

## Operating limits

### Operating range

61AF		Minimum	Maximum
<b>Condenser</b>			
Entering water temperature at start-up	°C	8	57
Leaving water temperature during operation	°C	30	65
Entering/leaving water temperature difference	K	3	**
<b>Evaporator</b>			
Entering air temperature*	°C	-20	40

\* Outside temperature: For transport and storage of the 61AF units the minimum and maximum allowable temperatures are -20°C and +50°C. It is recommended that these temperatures are used for transport by container.

\*\* Refer to the minimum unit flow rate.

**Note:** Do not exceed the maximum operating temperature.

### Plate heat exchanger water flow rate

61AF	Flow rate, l/s		
	Minimum	Maximum* with hydronic module	Maximum** without hydronic module
022	0.4	1.6	1.8
030	0.5	1.7	2.4
035	0.7	3.3	3.1
045	0.8	3.3	3.8
055	0.9	3.2	4.6
075	1.2	5.9	6.4
105	1.6	6.1	8.5

\* Maximum flow rate at an available pressure of 15 kPa.

\*\* Maximum flow rate at a water temperature difference of 3 K in the plate heat exchanger.

**Note:** For a domestic hot water application (leaving water temperature = 65°C), the water temperature difference must be at least 8 K.

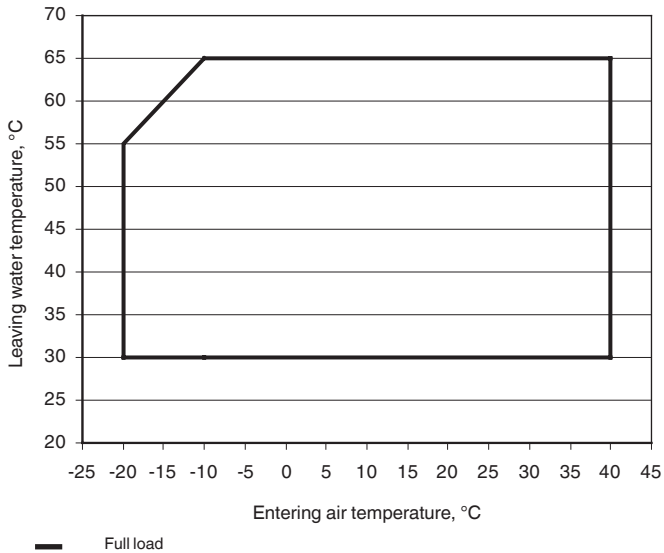

# Dimensions/clearances

## 61AF 022-035 units with and without hydronic module

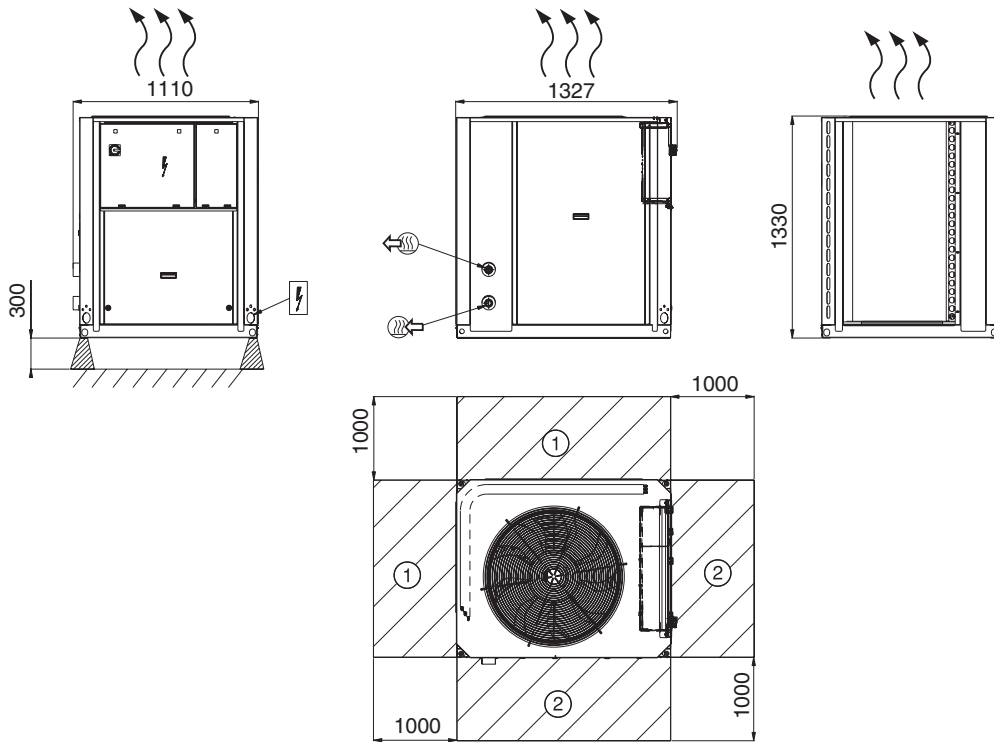

### Legend

All dimensions are in mm

- ① Required clearances for air flow
- ② Recommended space for maintenance
- Water inlet
- Water outlet
- Air outlet, do not obstruct
- Control box
- Power cable connection

## 61AF 045-055 units with and without hydronic module

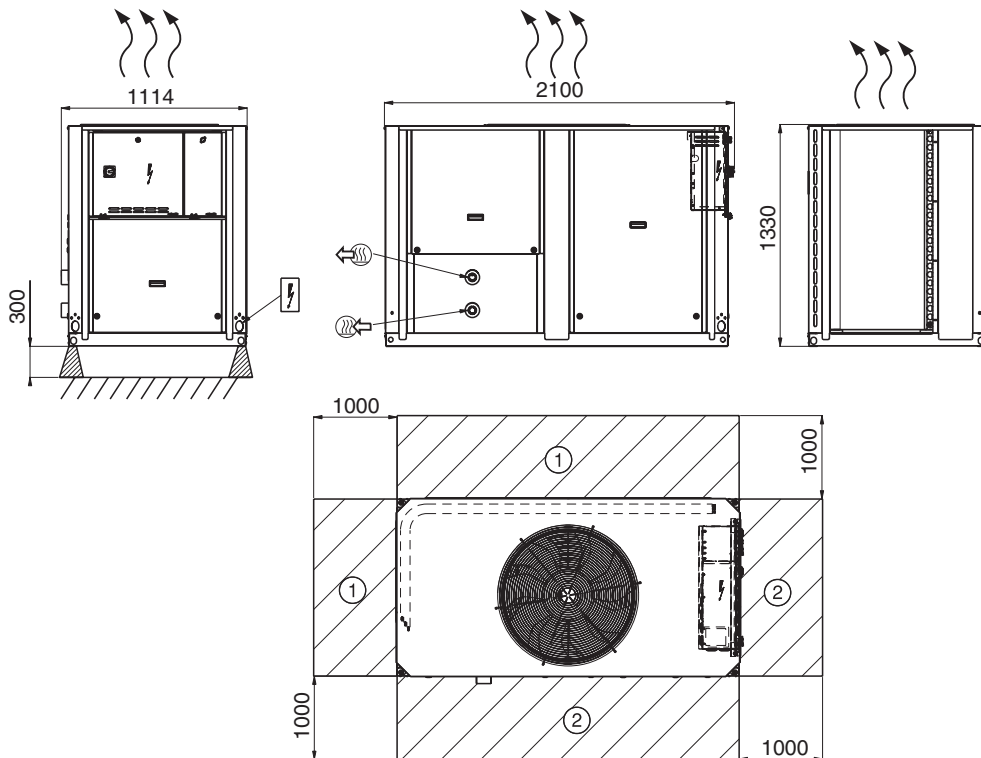

### NOTES:

- A Non-certified drawings. Refer to the certified dimensional drawings supplied with the unit or available on request, when designing an installation. For the location of fixing points, weight distribution and coordinates of the centre of gravity refer to the certified dimensional drawings.
- B In multiple-unit installations (maximum four units), the side clearance between the units should be increased from 1000 to 2000 mm.
- C The height of the solid surface must not exceed 2 m.

# Dimensions/clearances (continued)

## 61AF 075-105 units with and without hydronic module

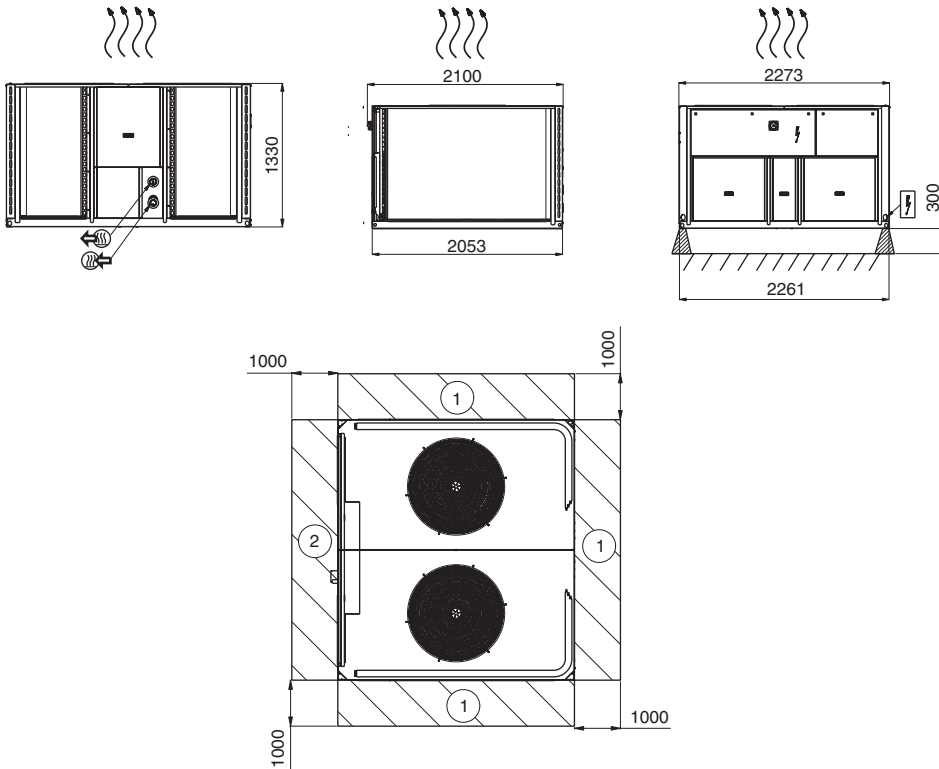

### Legend

All dimensions are in mm

- ① Required clearances for air flow
- ② Recommended space for maintenance
- ⊕ Water inlet
- ⊖ Water outlet
- ⋈ Air outlet, do not obstruct
- ⚡ Control box
- ⚡ Power cable connection

### NOTES:

- A Non-certified drawings. Refer to the certified dimensional drawings supplied with the unit or available on request, when designing an installation. For the location of fixing points, weight distribution and coordinates of the centre of gravity refer to the certified dimensional drawings.
- B In multiple-unit installations (maximum four units), the side clearance between the units should be increased from 1000 to 2000 mm.
- C The height of the solid surface must not exceed 2 m.



# Heating capacities

61AF EWT °C		Outside air temperature, °C																													
		-20				-15				-10				-5				0				2				5					
		Cap	Unit	Flow	Dp	Cap	Unit	Flow	Dp	Cap	Unit	Flow	Dp	Cap	Unit	Flow	Dp	Cap	Unit	Flow	Dp	Cap	Unit	Flow	Dp	Cap	Unit	Flow	Dp	Cap	Unit
kW	kW	l/s	kPa	kW	kW	l/s	kPa	kW	kW	l/s	kPa	kW	kW	l/s	kPa	kW	kW	l/s	kPa	kW	kW	l/s	kPa	kW	kW	l/s	kPa	kW	kW	l/s	kPa
022	25	10.2	4.80	0.49	1	12.1	4.80	0.58	2	13.9	4.80	0.67	2	15.9	4.80	0.76	3	18.0	4.60	0.87	4	19.0	4.60	0.91	4	20.4	4.60	0.98	5		
030		10.1	5.70	0.58	1	13.1	5.70	0.58	1	16.0	5.70	0.77	2	19.0	5.80	0.91	3	21.9	5.60	1.05	3	23.2	5.60	1.11	4	25.2	5.70	1.21	4		
035		15.6	6.60	0.75	1	18.1	6.80	0.87	2	21.0	6.90	1.01	3	24.3	7.00	1.16	3	27.7	6.90	1.33	4	29.2	7.00	1.40	5	31.6	7.00	1.52	5		
045		20.0	8.50	0.96	1	24.4	8.70	1.17	3	28.5	9.00	1.37	3	33.1	9.20	1.59	5	38.1	9.10	1.83	6	40.1	9.10	1.93	6	41.3	9.00	1.98	7		
055		25.6	9.40	1.23	2	29.9	10.0	1.43	3	34.5	10.4	1.66	4	39.8	10.7	1.91	5	45.3	10.8	2.17	6	47.5	10.8	2.28	6	50.3	10.9	2.42	7		
075		32.0	14.0	1.54	2	37.6	14.4	1.80	3	43.8	14.7	2.10	4	50.7	14.9	2.44	5	58.3	14.7	2.80	7	61.6	14.8	2.96	7	63.1	14.8	3.03	8		
105		47.6	19.3	2.29	4	54.9	19.9	2.64	5	64.0	20.4	3.08	6	74.1	20.9	3.56	8	85.4	21.2	4.10	11	90.2	21.2	4.33	12	97.6	21.7	4.69	14		
022	30	9.8	5.20	0.47	1	11.8	5.20	0.57	2	13.9	5.20	0.67	2	15.8	5.20	0.76	3	17.9	4.90	0.86	3	18.8	4.90	0.90	4	20.2	4.90	0.97	4		
030		10.2	5.90	0.49	1	13.1	6.00	0.62	1	15.9	6.00	0.76	2	18.8	6.10	0.91	3	21.7	6.00	1.04	3	22.9	6.10	1.10	4	24.8	6.10	1.19	4		
035		15.7	7.10	0.76	1	18.2	7.30	0.87	2	20.9	7.50	1.01	2	24.1	7.60	1.16	3	27.5	7.60	1.32	4	29.0	7.60	1.39	4	31.2	7.70	1.50	5		
045		18.7	9.10	0.89	1	23.4	9.30	1.12	3	28.2	9.60	1.36	3	32.7	9.80	1.57	4	37.6	9.80	1.81	6	39.6	9.80	1.90	6	41.8	9.80	2.01	7		
055		25.6	10.0	1.23	2	29.8	10.6	1.43	3	34.4	11.1	1.65	4	39.5	11.5	1.90	5	45.0	11.7	2.16	6	47.2	11.7	2.27	6	50.4	11.8	2.43	7		
075		31.8	14.9	1.53	2	37.3	15.4	1.79	3	43.4	15.8	2.09	4	50.3	16.1	2.42	5	57.8	16.0	2.78	6	61.0	16.0	2.93	7	63.8	16.1	3.07	8		
105		47.8	20.6	2.30	3	55.1	21.4	2.65	5	63.9	22.0	3.07	6	73.9	22.6	3.55	8	84.9	22.9	4.09	10	89.7	23.0	4.31	12	97.2	23.4	4.67	13		
022	35	10.0	5.50	0.48	1	11.9	5.50	0.57	2	13.9	5.50	0.67	2	15.7	5.60	0.76	3	17.8	5.30	0.86	3	18.6	5.30	0.90	4	20.0	5.30	0.96	4		
030		10.4	6.20	0.50	1	13.2	6.30	0.63	1	15.9	6.40	0.76	2	18.7	6.60	0.90	2	21.5	6.50	1.03	3	22.7	6.50	1.09	4	24.6	6.60	1.18	4		
035		15.9	7.70	0.77	1	18.3	7.90	0.88	2	21.0	8.10	1.01	2	24.0	8.30	1.16	3	27.4	8.20	1.32	4	28.8	8.30	1.39	4	30.9	8.40	1.49	5		
045		18.7	9.60	0.89	1	23.3	9.90	1.11	3	28.0	10.2	1.35	3	32.3	10.5	1.56	4	37.2	10.6	1.79	5	39.1	10.6	1.88	6	42.1	10.7	2.03	7		
055		25.7	10.6	1.24	2	29.8	11.3	1.44	3	34.3	11.9	1.65	3	39.3	12.3	1.89	4	44.7	12.6	2.16	6	46.9	12.6	2.26	6	50.2	12.8	2.42	7		
075		31.7	15.9	1.53	2	37.1	16.4	1.79	3	43.2	16.9	2.08	4	49.9	17.4	2.41	5	57.3	17.3	2.76	6	60.5	17.5	2.91	7	64.7	17.6	3.12	8		
105		48.1	22.0	2.32	3	55.4	23.0	2.67	5	64.0	23.8	3.08	6	73.8	24.5	3.56	8	84.7	24.9	4.08	10	89.4	25.0	4.31	11	96.8	25.4	4.66	13		
022	40	10.1	5.90	0.48	1	12.0	5.90	0.58	2	14.0	6.00	0.67	2	15.8	6.00	0.76	3	17.7	5.80	0.86	3	18.6	5.80	0.90	4	19.9	5.80	0.96	4		
030		9.5	6.60	0.45	1	12.5	6.70	0.60	1	15.4	6.90	0.74	2	18.4	7.20	0.88	2	21.4	7.10	1.03	3	22.5	7.10	1.09	3	24.4	7.20	1.18	4		
035		16.1	8.30	0.78	1	18.5	8.60	0.89	2	21.1	8.80	1.02	2	24.0	9.00	1.16	3	27.3	9.00	1.32	4	28.6	9.00	1.38	4	30.7	9.10	1.48	5		
045		19.1	10.3	0.91	1	23.5	10.6	1.12	3	27.9	11.0	1.35	3	32.1	11.3	1.55	4	36.7	11.5	1.77	5	38.7	11.5	1.87	6	41.7	11.7	2.01	6		
055		25.9	11.5	1.25	2	30.0	12.2	1.45	3	34.4	12.8	1.66	3	39.2	13.3	1.89	4	44.6	13.6	2.15	5	46.7	13.6	2.25	6	50.0	13.9	2.41	7		
075		31.7	17.0	1.53	2	37.1	17.6	1.79	3	43.0	18.2	2.08	4	49.7	18.8	2.40	5	57.0	18.8	2.75	6	60.1	19.0	2.90	7	65.0	19.3	3.13	8		
105		48.5	23.5	2.34	3	55.9	24.7	2.70	5	64.4	25.8	3.11	6	74.0	26.7	3.57	8	84.8	27.1	4.09	10	89.4	27.3	4.31	11	96.6	27.8	4.66	13		
022	45	10.4	6.30	0.50	1	12.2	6.40	0.58	2	14.1	6.50	0.68	2	15.9	6.50	0.77	3	17.8	6.40	0.86	3	18.6	6.40	0.90	4	19.9	6.40	0.96	4		
030		9.3	7.10	0.44	1	12.3	7.30	0.59	1	15.3	7.40	0.73	2	18.3	7.80	0.88	2	21.4	7.70	1.03	3	22.5	7.80	1.09	3	24.3	7.90	1.17	4		
035		15.9	9.00	0.76	1	18.7	9.30	0.90	2	21.2	9.50	1.03	2	24.1	9.70	1.16	3	27.2	9.70	1.32	4	28.6	9.80	1.38	4	30.6	10.0	1.48	5		
045		17.0	11.1	0.81	1	21.8	11.5	1.04	3	28.0	11.9	1.35	3	32.0	12.3	1.55	4	36.5	12.4	1.76	5	38.4	12.6	1.86	5	41.3	12.7	2.00	6		
055		25.8	12.7	1.23	2	30.4	13.3	1.47	3	34.7	13.9	1.67	3	39.3	14.3	1.90	4	44.5	14.7	2.15	5	46.7	14.8	2.26	6	49.8	15.0	2.41	6		
075		31.8	18.1	1.54	2	37.1	18.9	1.79	3	43.1	19.7	2.08	4	49.6	20.3	2.40	5	56.8	20.5	2.75	6	59.9	20.7	2.89	7	64.7	21.1	3.13	8		
105		49.0	25.0	2.37	3	56.6	26.6	2.73	5	64.9	27.9	3.14	6	74.5	29.0	3.60	8	85.0	29.7	4.11	10	89.6	29.9	4.33	11	96.8	30.4	4.67	13		
022	50	10.7	6.80	0.51	1	12.5	6.90	0.60	2	14.3	7.00	0.69	2	16.1	7.10	0.78	3	18.0	7.00	0.87	3	18.7	7.00	0.91	4	19.9	7.00	0.97	4		
030		10.5	7.60	0.50	1	13.2	7.90	0.63	1	16.0	8.10	0.76	2	18.8	8.50	0.90	2	21.5	8.50	1.04	3	22.6	8.60	1.09	3	24.3	8.70	1.18	4		
035		16.3	9.70	0.78	1	18.9	10.0	0.92	2	21.4	10.3	1.04	2	24.2	10.5	1.17	3	27.2	10.6	1.32	4	28.6	10.7	1.38	4	30.5	10.9	1.48	4		
045		18.9	12.1	0.90	1	23.3	12.5	1.11	3	27.7	12.8	1.32	3	32.1	13.3	1.55	4	36.4	13.6	1.76	5	38.2	13.7	1.85	5	41.1	13.9	1.99	6		
055		26.6	14.1	1.27	2	31.0	14.6	1.50	3	35.1	15.2	1.70	3	39.6	15.6	1.92	4	44.6	16.0	2.16	5	46.7	16.1	2.26	6	49.8	16.4	2.41	6		
075		32.0	19.4	1.55	2	37.3	20.4	1.81	3	43.2	21.2	2.09	4	49.7	22.0	2.41	5	56.8	22.3	2.75	6	59.8	22.6	2.90	6	64.6	23.0	3.13	7		
105		49.7	26.7	2.41	3	57.5	28.7	2.78	5	65.7	30.3	3.18	6	75.3	31.7	3.65	8	85.7	32.6	4.15	10	90.1	32.9	4.36	11	97.2	33.5	4.71	12		
022	55	-	-	-	-	-	-	-	-	14.9	8.30	0.36	1	16.7	8.50	0.41	1	18.5	8.40	0.45	1	19.2	8.50	0.47	1	20.4	8.50	0.49	1		
030		-	-	-	-	-	-	-	-	16.6	9.60	0.40	1	19.2	10.2	0.46	1	21.9	10.2	0.52	1	23.0	10.3	0.56	1	24.6	10.5	0.60	1		
035		-	-	-	-	-	-	-	-	20.9	12.1	0.50	1	24.1	12.4	0.58	1	27.3	12.4	0.65	1	28.6	12.5	0.70	1	30.6	12.7	0.74	1		
045		-	-	-	-	-	-	-	-	28.7	15.3	0.68	1	32.7	15.9	0.79	1	36.6	16.1	0.89	1	38.4	16.3	0.93	1	41.1	16.6	1.00	2		
055		-	-	-	-	-	-	-	-	36.6	18.4	0.89	1	40.2	18.7	0.96	1	45.2	19.1	1.08	1	47.2	19.2	1.15	2	50.3	19.5	1.22	2		
075		-	-	-	-	-	-	-	-	43.9	24.3	1.07	1	50.3	25.2	1.22	1	57.2	25.7	1.39	2	60.2	26.0	1.46	2						

# Heating capacities

61AF EWT °C		Outside air temperature, °C																													
		7				10				15				20				25				30				35					
		Cap	Unit	Flow	Dp	Cap	Unit	Flow	Dp	Cap	Unit	Flow	Dp	Cap	Unit	Flow	Dp	Cap	Unit	Flow	Dp	Cap	Unit	Flow	Dp	Cap	Unit	Flow	Dp		
kW	kW	l/s	kPa	kW	kW	l/s	kPa	kW	kW	l/s	kPa	kW	kW	l/s	kPa	kW	kW	l/s	kPa	kW	kW	l/s	kPa	kW	kW	l/s	kPa	kW	kW	l/s	kPa
022	25	21.5	4.60	1.03	5	23.0	4.60	1.11	6	23.2	4.60	1.11	6	23.2	4.60	1.11	6	23.2	4.50	1.11	6	23.2	4.50	1.11	6	23.2	4.50	1.11	6		
030		26.5	5.70	1.27	5	28.6	5.70	1.37	6	32.1	5.70	1.54	7	35.3	5.60	1.70	8	38.7	5.90	1.85	10	42.1	5.70	2.01	12	42.1	5.70	2.01	12		
035		33.3	7.10	1.60	6	36.0	7.20	1.73	7	40.4	7.30	1.94	8	38.2	7.40	1.83	7	39.6	7.50	1.89	8	41.8	7.60	2.00	9	41.8	7.60	2.00	9		
045		42.8	9.10	2.04	7	44.6	9.10	2.13	8	47.8	9.20	2.28	9	50.9	9.30	2.43	10	54.0	9.40	2.58	11	57.1	9.50	2.73	13	57.1	9.50	2.73	13		
055		51.4	10.9	2.47	7	52.4	10.9	2.50	8	55.1	11.0	2.63	8	58.9	11.1	2.81	10	62.7	11.2	2.99	11	66.5	11.3	3.18	12	66.5	11.3	3.18	12		
075		64.1	14.8	3.08	8	66.2	14.8	3.18	9	69.7	14.8	3.35	9	73.3	14.9	3.52	10	76.9	14.9	3.70	11	80.6	14.9	3.87	12	84.3	14.9	4.05	13		
105		102	21.9	4.90	15	109	22.3	5.23	17	121	23.2	5.81	21	123	23.3	5.92	22	126	23.4	6.03	22	128	23.6	6.14	23	130	23.7	6.25	24		
022	30	21.2	4.90	1.02	5	22.8	4.90	1.09	5	23.5	4.90	1.13	6	23.5	4.90	1.13	6	23.5	4.90	1.13	6	23.5	4.90	1.13	6	23.5	4.90	1.13	6		
030		26.1	6.10	1.26	5	28.1	6.10	1.35	5	31.7	6.20	1.53	7	34.9	6.20	1.68	8	38.4	6.40	1.84	10	41.8	6.50	2.00	11	41.8	6.50	2.00	11		
035		32.8	7.70	1.58	6	35.4	7.80	1.70	6	39.8	8.00	1.92	8	42.9	8.10	2.05	9	46.2	8.30	2.21	10	50.4	8.40	2.41	12	50.4	8.40	2.41	12		
045		43.6	9.90	2.08	7	46.1	9.90	2.20	8	50.2	10.1	2.40	10	54.4	10.2	2.60	11	58.6	10.3	2.80	13	62.8	10.4	3.00	15	62.8	10.4	3.00	15		
055		51.9	11.9	2.49	7	53.2	12.0	2.54	8	56.7	12.2	2.71	9	61.2	12.3	2.92	10	65.7	12.5	3.14	12	70.2	12.7	3.35	13	70.2	12.7	3.35	13		
075		64.7	16.1	3.11	8	66.7	16.2	3.21	8	70.1	16.2	3.37	9	73.7	16.3	3.55	10	77.3	16.3	3.72	11	81.0	16.4	3.90	12	84.7	16.4	4.07	13		
105		102	23.6	4.89	15	108	24.0	5.20	16	120	24.8	5.76	20	124	25.1	5.99	21	127	25.2	6.10	22	129	25.3	6.21	23	131	25.5	6.32	24		
022	35	20.9	5.30	1.01	5	22.5	5.40	1.08	5	23.9	5.40	1.15	6	23.9	5.30	1.15	6	23.9	5.30	1.15	6	23.9	5.30	1.15	6	23.9	5.30	1.15	6		
030		25.9	6.70	1.25	4	27.8	6.70	1.34	5	31.3	6.80	1.51	6	34.6	6.80	1.67	8	38.1	7.10	1.82	9	41.5	7.20	1.98	11	41.5	7.20	1.98	11		
035		32.5	8.50	1.56	5	35.0	8.60	1.68	6	39.3	8.70	1.90	7	42.3	8.90	2.02	8	45.5	9.10	2.17	10	49.6	9.20	2.37	12	49.6	9.20	2.37	12		
045		44.1	10.8	2.11	7	47.0	10.8	2.25	8	52.0	11.0	2.48	10	56.9	11.1	2.72	12	61.9	11.2	2.96	14	66.9	11.3	3.19	17	66.9	11.3	3.19	17		
055		52.0	12.9	2.51	7	53.5	13.1	2.56	8	57.3	13.3	2.74	9	62.2	13.6	2.97	10	67.1	13.8	3.21	12	72.0	14.1	3.44	14	72.0	14.1	3.44	14		
075		65.6	17.7	3.16	8	67.3	17.7	3.24	8	70.8	17.8	3.41	9	74.3	17.9	3.58	10	77.8	18.0	3.75	11	81.5	18.0	3.93	12	85.2	18.1	4.10	13		
105		102	25.7	4.90	14	108	26.1	5.20	16	119	26.8	5.73	19	126	27.3	6.07	21	128	27.4	6.18	22	130	27.5	6.29	23	133	27.6	6.40	24		
022	40	20.8	5.80	1.00	4	22.3	5.80	1.07	5	24.4	5.80	1.18	6	24.4	5.80	1.18	6	24.4	5.80	1.18	6	24.4	5.80	1.18	6	24.4	5.80	1.18	6		
030		25.7	7.30	1.24	4	27.6	7.30	1.33	5	30.9	7.40	1.49	6	34.4	7.50	1.66	7	37.8	7.80	1.81	9	41.2	8.00	1.97	11	41.2	8.00	1.97	11		
035		32.2	9.20	1.55	5	34.6	9.30	1.67	6	38.9	9.50	1.88	7	41.8	9.70	2.00	8	45.0	9.90	2.15	9	49.0	10.1	2.34	11	49.0	10.1	2.34	11		
045		43.6	11.8	2.08	7	46.6	11.9	2.22	8	51.5	12.1	2.46	10	56.4	12.3	2.69	12	61.3	12.5	2.93	14	66.2	12.7	3.16	16	66.2	12.7	3.16	16		
055		52.2	14.0	2.52	7	53.8	14.2	2.57	8	58.0	14.5	2.77	9	63.2	14.9	3.02	10	68.4	15.2	3.27	12	73.7	15.6	3.52	14	73.7	15.6	3.52	14		
075		66.7	19.4	3.22	8	68.1	19.4	3.28	8	71.6	19.5	3.45	9	75.1	19.7	3.62	10	78.6	19.8	3.79	11	82.2	19.9	3.97	12	85.9	20.0	4.14	13		
105		102	28.1	4.90	14	108	28.5	5.22	16	119	29.2	5.74	19	128	29.8	6.17	22	130	30.0	6.27	22	132	30.1	6.38	23	135	30.2	6.49	24		
022	45	20.8	6.40	1.00	4	22.1	6.40	1.07	5	24.7	6.40	1.19	6	24.9	6.40	1.21	6	24.9	6.40	1.21	6	24.9	6.40	1.21	6	24.9	6.40	1.21	6		
030		25.5	8.00	1.23	4	27.4	8.10	1.33	5	30.7	8.20	1.49	6	34.3	8.40	1.66	7	37.6	8.70	1.80	9	41.1	8.90	1.96	10	41.1	8.90	1.96	10		
035		32.0	10.1	1.55	5	34.3	10.2	1.66	6	38.5	10.4	1.86	7	41.2	10.6	1.97	8	44.2	10.9	2.11	9	48.1	11.1	2.30	11	48.1	11.1	2.30	11		
045		43.3	12.8	2.07	7	46.2	13.0	2.21	8	51.1	13.3	2.44	9	55.9	13.6	2.67	11	60.8	13.9	2.90	13	65.6	14.1	3.14	15	65.6	14.1	3.14	15		
055		52.0	15.2	2.51	7	53.6	15.4	2.56	7	57.5	15.8	2.75	8	62.6	16.2	2.99	10	67.7	16.6	3.23	12	72.8	16.9	3.48	13	72.8	16.9	3.48	13		
075		67.8	21.3	3.28	8	69.3	21.3	3.35	9	72.5	21.5	3.50	9	76.1	21.7	3.68	10	79.6	21.8	3.85	11	83.2	22.0	4.02	12	86.9	22.1	4.20	13		
105		102	30.8	4.92	14	109	31.3	5.25	16	120	32.1	5.77	19	130	32.8	6.29	22	132	33.0	6.40	23	135	33.1	6.51	23	137	33.3	6.62	24		
022	50	20.8	7.10	1.01	4	22.1	7.10	1.07	5	24.5	7.10	1.19	6	25.6	7.10	1.24	6	25.6	7.10	1.24	6	25.6	7.10	1.24	6	25.6	7.00	1.24	6		
030		25.5	8.80	1.23	4	27.4	8.90	1.33	5	30.6	9.10	1.48	6	34.1	9.30	1.65	7	37.3	9.60	1.78	8	40.7	9.90	1.94	10	40.7	9.90	1.94	10		
035		31.9	11.0	1.55	5	34.1	11.1	1.65	5	38.1	11.4	1.84	7	40.6	11.6	1.94	7	43.5	11.8	2.08	8	47.1	12.1	2.25	10	47.1	12.1	2.25	10		
045		43.1	14.1	2.06	6	45.9	14.3	2.19	7	50.7	14.6	2.42	9	55.5	15.0	2.65	11	60.3	15.3	2.88	13	65.0	15.7	3.11	15	65.0	15.7	3.11	15		
055		51.9	16.5	2.52	7	53.4	16.8	2.55	7	57.2	17.2	2.74	8	62.2	17.6	2.97	10	67.1	18.0	3.21	11	72.1	18.4	3.44	13	72.1	18.4	3.44	13		
075		67.9	23.3	3.29	8	70.8	23.5	3.43	9	73.7	23.7	3.57	9	77.3	23.9	3.74	10	80.9	24.2	3.91	11	84.5	24.4	4.09	12	88.1	24.6	4.27	13		
105		102	33.9	4.94	14	110	34.5	5.31	16	120	35.4	5.82	19	132	36.3	6.37	22	135	36.5	6.55	23	138	36.7	6.66	24	140	36.9	6.77	25		
022	55	21.1	8.60	0.51	1	22.4	8.60	0.54	1	24.5	8.70	0.60	2	26.9	8.70	0.65	2	27.1	8.70	0.66	2	27.1	8.70	0.66	2	27.1	8.70	0.66	2		
030		25.7	10.6	0.62	1	27.4	10.8	0.67	1	30.6	11.1	0.74	2	33.8	11.3	0.82	2	37.0	11.7	0.88	2	40.2	12.0	0.96	3	40.2	12.0	0.96	3		
035		31.8	12.9	0.77	1	33.9	13.0	0.82	2	37.4	13.3	0.91	2	39.7	13.6	0.95	2	42.2	14.0	1.01	2	45.5	14.3	1.09	3	45.5	14.3	1.09	3		
045		42.8	16.8	1.02	2	45.5	17.0	1.09	2	49.9	17.5	1.19	2	54.3	17.9	1.30	3	58.7	18.4	1.40	3	63.1	18.8	1.51	4	63.1	18.8	1.51	4		
055		52.3	19.6	1.27	2	53.6	19.9	1.28	2	57.3	20.3	1.37	2	62.1	20.7	1.48	3	66.9	21.1	1.60	3	71.6	21.5	1.71	3	71.6	21.5	1.71	3</		

# Hydronic module (option 116)

The hydronic module option reduces the installation time. The heat pump is factory-equipped with the main hydronic components required for the installation: screen filter, water pump, safety valve, water pressure transducer, flow switch.

The Pro-Dialog+ control allows integration of system and water pump protection devices (insufficient water flow rate, water pressure, water flow rate etc.).

The pump supplied with the hydronic module is a multi-speed pump.

An automatic pump start-up algorithm protects the heat exchanger and the hydronic module piping against frost down to -10°C outside air temperature, as standard. If necessary, increased frost protection down to -20 °C is possible by adding heaters to the hydronic module piping (see option 42).

The hydronic module option is integrated into the heat pump without increasing its dimensions and saves the space normally used for the water pump.

## Hydronic module



## Typical hydronic circuit diagram

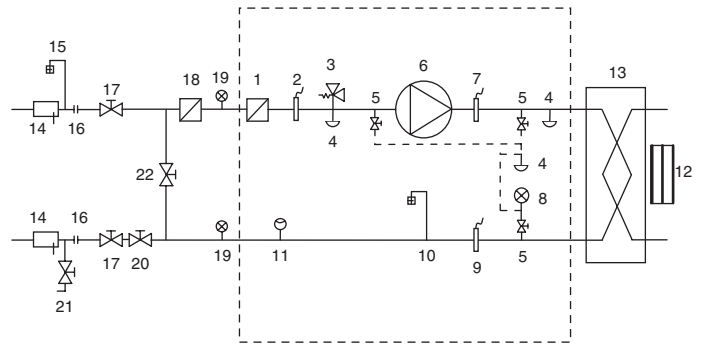

### Legend

#### Components of the unit and hydronic module

- 1 Victaulic screen filter
- 2 Pressure sensor  
Note: Gives pump suction pressure information (see installation manual)
- 3 Safety valve
- 4 Water drain valve
- 5 Shut-off valve
- 6 Water pump
- 7 Temperature sensors, BPHE inlet  
Note: Gives heat exchanger entering temperature information (see installation manual)
- 8 Pressure gauge  
Note: Allows measuring of the pump suction pressure, the pump leaving pressure and the heat exchanger leaving pressure
- 9 Temperature sensor, BPHE outlet  
Note: Gives heat exchanger leaving temperature information (see installation manual)
- 10 Automatic air vent
- 11 Flow switch
- 12 Plate heat exchanger frost protection heater
- 13 Plate heat exchanger

#### Installation components

- 14 Temperature probe well
  - 15 Air vent
  - 16 Flexible connection
  - 17 Shut-off valve
  - 18 Screen filter (obligatory for a unit without hydronic module)
  - 19 Pressure gauge
  - 20 Water flow control valve
  - 21 Charge valve
  - 22 Frost protection bypass valve (when shut-off valves [17] are closed during winter)
- Hydronic module (unit with hydronic module)

#### Notes:

- Units without hydronic module (standard units) are equipped with a flow switch and two temperature sensors (7 and 9).
- For units equipped with hydronic module, the pressure sensor located upstream of the pump to prevent cavitation is installed on a connection without Schraeder valves. Depressurise and drain the system before any intervention.

## Physical and electrical data, units with hydronic module

61AF		022	030	035	045	055	075	105
<b>Operating weight*</b>								
Unit with hydronic module	kg	349	403	436	524	549	926	1044
<b>Hydronic module</b>								
Maximum operating pressure	kPa	400	400	400	400	400	400	400
Water filter		Victaulic screen filter						
<b>Pumps</b>								
Water pump		TOP-S 25	TOP-S 25	TOP-S40	TOP-S40	TOP-S40	TOP-S50	TOP-S50
Shaft power input	kW	0.18	0.18	0.35	0.35	0.35	0.45	0.45
Power input**	kW	0.42	0.42	0.63	0.63	0.63	0.95	0.95
Nominal operating current draw	A	0.4	0.4	0.6	0.6	0.7	1.3	1.5
Maximum current draw at 400 V***	A	0.8	0.8	1.3	1.3	1.3	1.7	1.7
<b>Water connections (with hydronic module)</b>								
Connections	inch	1-1/4	1-1/4	1-1/2	1-1/2	1-1/2	2	2
Outside diameter	mm	42.4	42.4	48.3	48.3	48.3	60.3	60.3

\* Weight shown is a guideline only. To find out the unit refrigerant charge, please refer to the unit nameplate.

\*\* To obtain the maximum power input for a unit with hydronic module, add the maximum unit power input to the pump power input.

\*\*\* To obtain the maximum operating current draw for a unit with hydronic module, add the maximum unit current draw to the pump current draw.

# Available static system pressure

Plate heat exchanger pressure drop - for pure water at 20°C

## 61AF 022-045

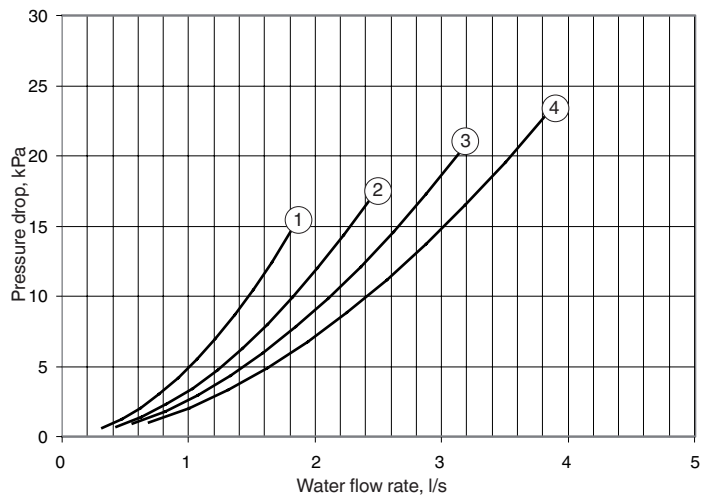

- 1 61AF 022
- 2 61AF 030
- 3 61AF 035
- 4 61AF 045

## 61AF 055-105

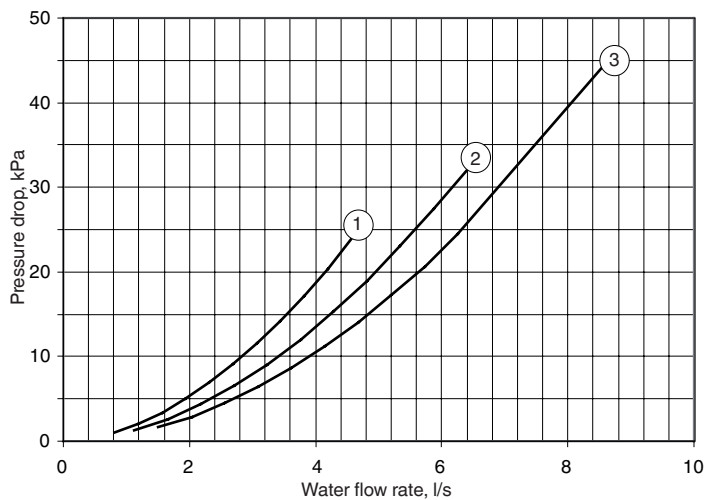

- 1 61AF 055
- 2 61AF 075
- 3 61AF 105

## Pump pressure/flow rate curves for units with hydronic module - for pure water at 20°C

The 61AF units are equipped with a fixed-speed pump with three different speeds.

These speeds can be manually adjusted by changing the speed terminal board inside the terminal box (this operation can only be carried out by approved personnel). The speed initially selected corresponds to standard use for heating water loops. If this speed needs to be changed, the pressure/flow curves for the three speeds are shown below.

61AF	Condenser water flow rate, l/s	
	Minimum	Maximum*
022	0.4	1.8
030	0.5	2.4
035	0.7	3.1
045	0.8	3.8
055	0.9	4.6
075	1.1	6.4
105	1.5	8.5

\* Maximum flow rate at a water temperature difference of 3 K in the plate heat exchanger (unit without hydronic module)

### 61AF 022-030

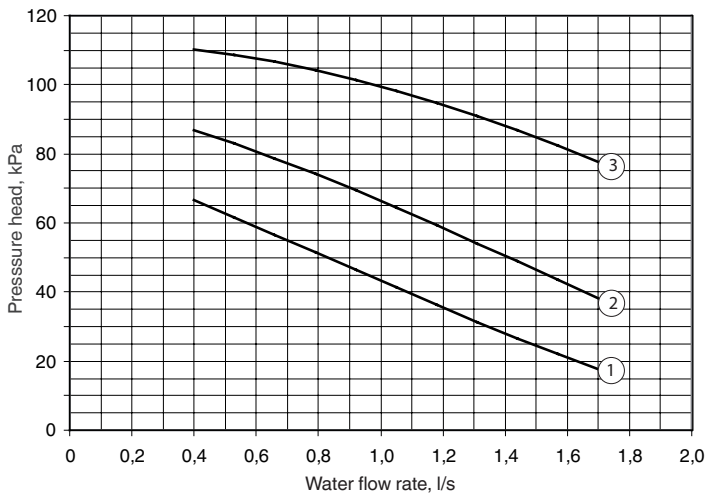

- 1 61AF 022-030 (speed 1)
- 2 61AF 022-030 (speed 2): selected
- 3 61AF 022-030 (speed 3)

### 61AF 035-055

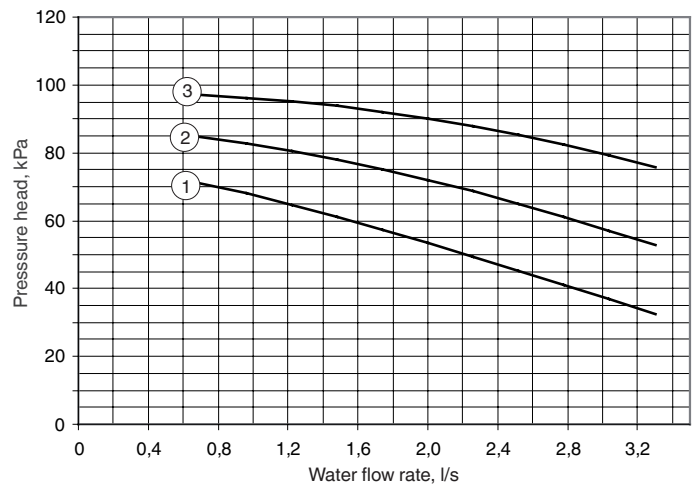

- 1 61AF 035-055 (speed 1)
- 2 61AF 035-055 (speed 2): selected
- 3 61AF 035-055 (speed 3)

### 61AF 075-105

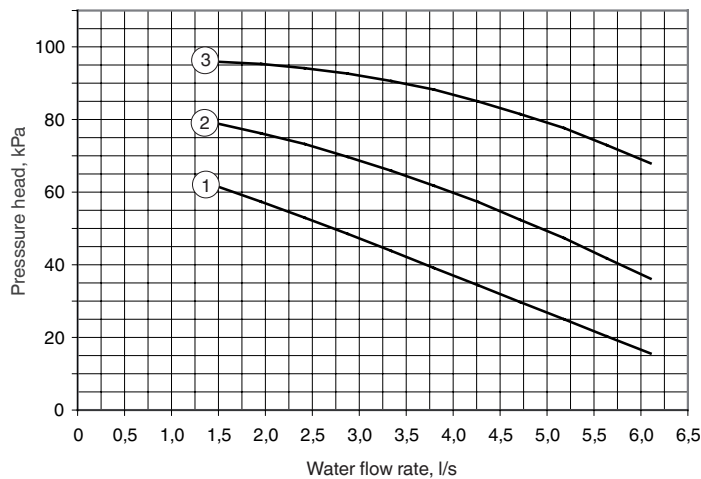

- 1 61AF 075-105 (speed 1)
- 2 61AF 075-105 (speed 2): selected
- 3 61AF 075-105 (speed 3)

# Available static system pressure (cont.)

## Available system pressure for units with hydronic module - for pure water at 20°C

The available pressure curves for the 61AF units are given for the speed initially selected. If the speed is changed by the user, the curves below do not apply.

61AF	Condenser water flow rate, l/s	
	Minimum	Maximum*
022	0.4	1.6
030	0.5	1.7
035	0.7	3.3
045	0.8	3.3
055	0.9	3.2
075	1.1	5.9
105	1.5	8.5

\* Maximum flow rate at an available pressure of 15 kPa (unit with hydronic module).

### 61AF 022-030

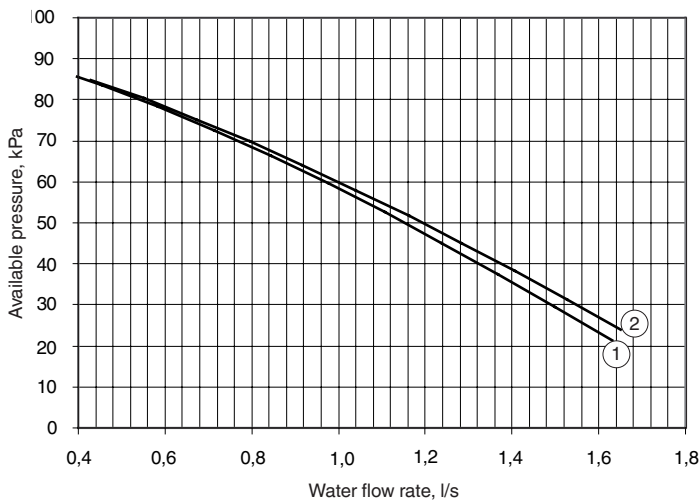

- 1 61AF 022
- 2 61AF 030

### 61AF 035-055

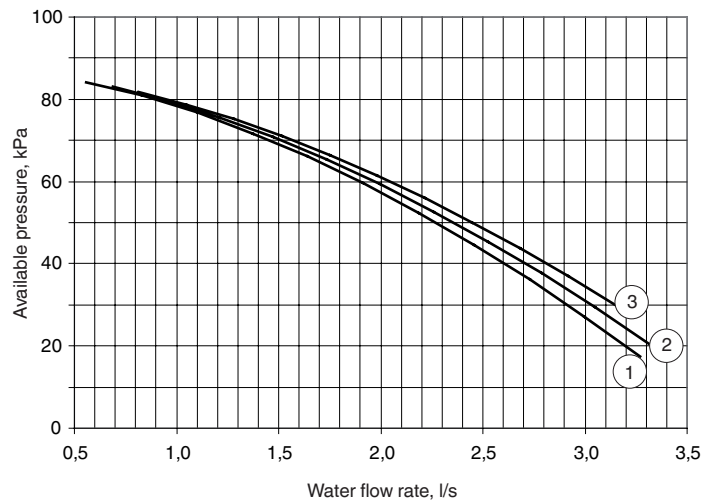

- 1 61AF 035
- 2 61AF 045
- 3 61AF 055

### 61AF 075-105

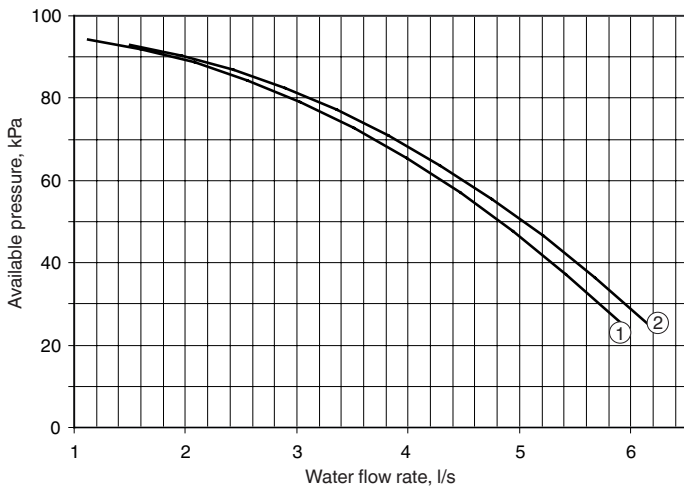

- 1 61AF 075
- 2 61AF 105



Carrier is participating in the Eurovent Certification Programme for liquid chilling packages. Products are as listed in the Eurovent Directory of Certified Products or on the Internet site [www.eurovent-certification.com](http://www.eurovent-certification.com).



Order No.: 16110-20, 10.2010. Supersedes order No.: 16110-20, 03.2010.  
Manufacturer reserves the right to change any product specifications without notice.  
The cover photo is solely for illustration purposes and is not contractually binding.

Manufactured by: Carrier SCS, Montluel, France.  
Printed in the Netherlands.