



United Technologies

PRODUCT SELECTION DATA

AIR-COOLED FIXED-SPEED SCREW CHILLER



- Very economical operation
- Low sound levels
- Simple installation
- Environmentally responsible
- Exceptional reliability

30XB / 30XBP 250-1700

Nominal cooling capacity 267-1682 kW - 50 Hz

AQUAFORCE[®]

The AquaForce™ 30XB and 30XBP liquid chillers are the economic solution for commercial and industrial applications where high reliability and economic operation in all climate conditions are key customer requirements.

The AquaForce™ 30XB and 30XBP liquid chillers are designed to meet current and future regulations for energy efficiency and operating sound levels. They use the latest Carrier technologies:

- Carrier 06T twin-rotor fixed-speed screw compressors.
- Low noise 6th generation of Carrier Flying Bird™ fans with AC motor (30XB) or EC motor (30XBP).
- Carrier flooded shell-and-tube evaporator with new copper tube design for low pressure drops
- 2nd generation of “V” shape Carrier Novation™ microchannel heat exchangers with optional Enviro-Shield coatings.
- Carrier Touch Pilot® control with color touch screen user interface that includes 10 languages and integrated web-server.



CARRIER participates in the ECP programme for LCP/HP
Check ongoing validity of certificate:
www.eurovent-certification.com
www.certiflash.com



Original document

CUSTOMER BENEFITS

The range is available in 3 efficiency levels.

■ 30XB standard unit

The AquaForce™ 30XB is equipped with fixed-speed screw compressors and fixed-speed fans with AC motors. The 30XB offers an economical solution whilst providing high full load efficiency for process applications and operation in high ambients.

(Average SEPR of 5.2, average SEER of 4.2, average EER of 3.1)

■ 30XBwith variable-speed AC fan motors (Option 17)

The 30XB with variable-speed AC fan motors offers an economical solution to enhance seasonal energy efficiency levels for comfort applications.

(Average SEPR of 5.5, average SEER of 4.3, average EER of 3.1)

■ 30XBP premium unit

The 30XBP premium unit is equipped with EC fans and additional heat exchange surface to improve both the full load and part load energy efficiency. The 30XBP provides very cost effective operation in both process and comfort applications through the use of state of the art EC fan technology.

(Average SEPR of 5.9, average SEER of 4.4, average EER of 3.2)

Very economical operation

Exceptionally high full load and part load energy efficiency:

- 30XB version with Eurovent energy efficiency class A and B, ESEER up to 4.3 and SEER 12/7°C up to 4.4 with option 17 in accordance with EN14825.
- 30XBP version with Eurovent energy efficiency class A, ESEER up to 4.4 and SEER 12/7°C up to 4.6 in accordance with EN14825.
- Twin-rotor screw compressor equipped with a high-efficiency motor and a variable capacity valve that permits exact matching of the cooling capacity to the load.
- Novation™ aluminium condenser with high-efficiency micro-channels.
- Flooded shell-and-tube evaporator with new generation of cooler tubes to reduce exchanger pressure drops, especially in applications with high percentage of glycol.
- Electronic expansion device permitting operation at a lower condensing pressure and improved utilisation of the evaporator heat exchange surface (superheat control).
- Economiser system with electronic expansion device for increased cooling capacity.

Low operating sound levels

■ Compressors

- Discharge dampers integrated in the oil separator (Carrier patent).
- Silencer on the economiser return line.
- Compressor and oil separator acoustic enclosure, reducing radiated noise (option).

■ Condenser section

- Condenser coils in wide angle V configuration, allowing quieter air flow across the coil
- Low-noise 6th generation Flying Bird fans, made of a composite material (Carrier patent), are now even quieter and do not generate intrusive low-frequency noise
- Inverter driven EC fans on 30XBP version eliminate start stop noise during part load operation.
- Rigid fan mounting preventing start-up noise (Carrier patent).

Simple installation

■ Integrated hydraulic module (option)

- Centrifugal low or high-pressure water pump (as required), based on the pressure loss of the hydraulic installation

- Single or dual pump (as required) with run time balancing and automatic changeover to the back-up pump if a fault develops
- Water filter to protect pump against circulating debris
- High-capacity membrane expansion tank ensures pressurisation of the water circuit
- Thermal insulation and aluminium cladding (option)
- Pressure sensor to check filter condition and for direct numerical display of the water flow rate with an estimate of the instantaneous cooling capacity at the control interface
- Water flow control valve.

■ Simplified electrical connections

- Main disconnect switch with high trip capacity
- Transformer to supply the integrated control circuit (400/24 V).

■ Fast commissioning

- Systematic factory operation test before shipment
- Quick-test function for step-by-step verification of the controls, expansion devices, fans and compressors.

Environmental responsibility

■ R-134a refrigerant

- Range designed for use with R-134a refrigerant with the possibility to upgrade to ultra-low global warming potential R-1234ze refrigerant on site in the future.
- 40% reduction in the refrigerant charge through the use of micro-channel heat exchangers

■ Leak-tight refrigerant circuit

- Reduction of leaks as no capillary tubes and flare connections are used
- Verification of pressure transducers and temperature sensors without transferring refrigerant charge
- Liquid line service valve for simplified maintenance (option).

Exceptional reliability

■ Screw compressors

- Industrial-type screw compressors with oversized bearings and motor cooled by suction gas.
- All compressor components are easily accessible on site minimising down-time.
- Dedicated electronic compressor protection module.

■ Air condenser

2nd generation of "V" shape Carrier Novation™ aluminium microchannel heat exchangers (MCHE) with high corrosion resistance. The all aluminium design eliminates the formation of galvanic currents between aluminium and copper that cause coil corrosion in saline or corrosive environments.

■ Evaporator

Thermal insulation with aluminium sheet finish (option) for improved resistance to mechanical and UV damage.

■ Auto-adaptive control

- Control algorithm prevents excessive compressor cycling (Carrier patent)
- Automatic compressor unloading in case of abnormally high condensing pressure. If condenser coil fouling or fan failure occurs, the Aquaforce continues to operate, but at reduced capacity

■ Exceptional endurance tests

- Partnerships with specialised laboratories and use of sophisticated finite element stress analysis for the design of critical components.
- Transport simulation test in the laboratory on a vibrating table. The test is based on a military standard and equivalent to 4000 km by truck.
- Salt mist corrosion resistance test in the laboratory for increased corrosion resistance.

TECHNICAL INSIGHTS

Touch Pilot Control

Touch Pilot, user interface



- New innovative smart control features:
 - An intuitive and user-friendly, coloured, 5" interface (7" optional)
 - Direct access to the unit's technical drawings and the main service documents
 - Screen-shots with concise and clear information in local languages
 - Complete menu, customised for different users (end user, service personnel and Carrier-factory technicians)
 - Easy access to the control panel with inclined touch screen mounting to ensure legibility under any lighting conditions
 - Safe operation and unit setting: password protection ensures that unauthorised people cannot modify any advanced parameters
 - Simple and "smart" intelligence uses data collection from the constant monitoring of all machine parameters to optimise unit operation.
- Energy management:
 - Internal time schedule clock controls chiller on/off times and operation at a second set-point
 - The DCT (Data Collection Tool) records the alarms history to simplify and facilitate service operations.

Remote Management (Standard)

- Units with Touch Pilot control can be easily accessed from the internet, using a PC with an Ethernet connection. This makes remote control quick and easy and offers significant advantages for service operations.
- Aquaforce is equipped with an RS485 serial port that offers multiple remote control, monitoring and diagnostic possibilities. When networked with other Carrier equipment through the CCN (Carrier Comfort Network - proprietary protocol), and in conjunction with one of Carrier's network products (Chiller System Manager or Plant system Manager) it forms part of a fully integrated and balanced HVAC system (optional).
- Aquaforce also communicates with other building management systems via optional communication gateways.
- The following commands/visualisations are possible from remote connection:
 - Start/stop of the machine
 - Dual set-point management: through a dedicated contact is possible to activate a second set-point (for example, during unoccupied mode).

- Demand limit setting: to limit the maximum chiller capacity to a predefined value
- Water pump control: these outputs control the contactors of one/two evaporator water pumps
- Automatic changeover of pumps in the event of a fault (only with options 116C/116G).
- Operation visualisation: indication if the unit is operating or in stand-by (no cooling load), (no cooling load) - alarm visualisation.

Remote Management (EMM option)

- The Energy Management Module (EMM) offers extended remote control possibilities:
 - Room temperature: Permits set-point reset based on the building indoor air temperature (if Carrier thermostat are installed)
 - Set-point reset: Allows reset of the cooling set-point based on a 4-20 mA or 0-10 V signal
 - Demand limit: Permits limitation of the maximum chiller capacity based on 0-10 V signal
 - Demand limit 1 and 2: Closing of these contacts limits the maximum chiller capacity to two predefined values
 - User safety: This contact can be used for any customer safety loop; opening the contact generates a specific alarm
 - Ice storage end: When ice storage has finished, this input permits return to the second set-point (unoccupied mode)
 - Time schedule override: closing this contact cancels the programmed time schedule.
 - Out of service: This signal indicates that the chiller is completely out of service
 - Chiller capacity: This analogue output (0-10 V) gives an immediate indication of the chiller capacity
 - Alert indication: This volt-free contact indicates the necessity to carry out a maintenance operation or the presence of a minor fault
 - Compressors running status: Set of outputs (one for each compressor) indicating which compressors are running.

06T Screw Compressor

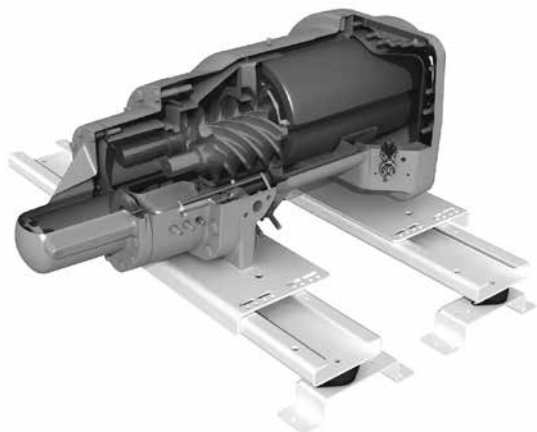

99.7%* of units without a compressor failure

* Quality rate measured over a period of 15 years operation

The Carrier 06T screw compressor benefits from Carrier's long experience in the development of twin-rotor screw compressors. The compressor is equipped with bearings with oversized rollers, oil pressure lubricated for reliable and durable operation, even at maximum load.

A variable control valve controlled by the oil pressure permits infinitely variable cooling capacity. This system allows optimal adjustment of the compressor cooling capacity and ensures exceptionally high stability of the chilled water leaving temperature.

Among the other advantages: if a fault occurs e.g. if the condenser is fouled or at very high outside temperature, the compressor does not switch off, but continues operation with a reduced capacity (unloaded mode).

The compressor is equipped with a separate oil separator that minimises the amount of oil in circulation in the refrigerant circuit and, with its integrated silencer, considerably reduces discharge gas pulsations for much quieter operation.

Novation® Heat Exchangers with Micro-Channel coil Technology

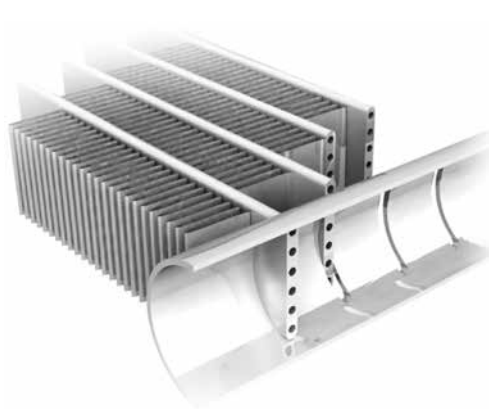

Already utilised in the automobile and aeronautical industries for many years, the Novation™ MCHE micro-channel heat exchanger used in the Aquaforce is entirely made of aluminium. This one-piece concept significantly increases its corrosion resistance by eliminating the galvanic currents that are created when two different metals (copper and aluminium) come into contact in traditional heat exchangers. Unlike traditional heat exchangers the Novation™ MCHE heat exchanger can be used in moderate marine and urban environments (Carrier recommendation).

From an energy efficiency point-of-view the Novation™ MCHE heat exchanger is approximately 10% more efficient than a traditional coil and allows a 40% reduction in the amount of refrigerant used in the chiller. The low thickness of the Novation™ MCHE reduces air pressure losses by 50% and makes it susceptible to very little fouling (e.g. by sand). Cleaning of the Novation™ MCHE heat exchanger is very fast using a high-pressure washer.

Carrier Novation® MCHE with Super Enviro-shield® coating, the ideal customer choice

To further enhance long-term performance, and to protect coils from early deterioration, Carrier offers (as options) dedicated treatments for installations in corrosive environments.

The Novation™ MCHE with Enviro-Shield protection (option 262) are recommended for installations in moderately corrosive environments. The Enviro-Shield protection utilises corrosion inhibitors which actively arrest oxidation in case of mechanical damage.

The Novation™ MCHE with the exclusive Super Enviro-Shield protection (option 263) are recommended for installations in corrosive environments. The Super Enviro-Shield protection consist in an extremely durable and flexible epoxy coating uniformly applied over all coil surfaces for complete isolation from the contaminated environment.

TECHNICAL INSIGHTS

Novation® Heat Exchangers with Micro-Channel coil Technology

After a total of more than 7,000 hours of testing following various test standards in UTC laboratories, the Carrier Novation® MCHE with Super Enviro-shield® coating appears to be the ideal customer choice to minimize the harmful effects of corrosive atmospheres and ensure long equipment life.

- Best corrosion resistance per ASTM B117/D610 test
- Best heat transfer performance per Carrier Marine 1 test
- Proven reliability per ASTM B117 test

Coil Types (ranked by performance)	Visual Corrosion Evaluation	Heat Transfer Performance Degradation	Time to Failure	Test Campaign Conclusions
Super Enviro-shield® Novation™ MCHE	Very good	Very good	No coil leak	Best
Super Enviro-shield® Cu/Al coil	Very good	Good	No coil leak	Very good
Enviro-shield® Novation™ MCHE	Very good	Good	No coil leak	Very good
Al/Al coil	Very good	Good	No coil leak	Very good
Novation™ MCHE	Good	Good	No coil leak	Good
Cu/Cu coil	Good	Good	Leak	Acceptable
Blygold® Cu/Al coil	Good	Good	No coil leak	Acceptable
Precoat Cu/Al coil	Bad	Bad	No coil leak	Bad
Cu/Al coil	Bad	Bad	No coil leak	Bad

New Generation of Flying Bird VI fans with EC motor



The 30XB and 30XBP utilize Carrier's 6th generation Flying Bird™ fan technology, engineered for maximum efficiency, super low noise, and wide operating range. The fan includes Carrier patented rotating shroud technology and back-swept blades with a unique wave-serration trailing edge inspired from nature.

It was designed and optimized for the 30XB air management system configuration and heat exchanger technology and is offered with induction and EC motor options. The fan meets the latest European eco-design requirements for fan efficiency. The fan uses Carrier's robust and proven injection molded composite-thermoplastic construction.

OPTIONS

Options	No.	Description	Advantages	Use for 30XB / 30XBP
Coil with anti-corrosion post treatment	2B	Factory application of Blygold Polual treatment on the copper/aluminum coils	Improved corrosion resistance, recommended for industrial, rural and marine environments	30XB/30XBP 250-1700
Corrosion protection, traditional coils	3A	Fins made of pre-treated aluminum (polyurethane and epoxy)	Improved corrosion resistance, recommended for moderate marine and urban environments	30XB/30XBP 250-1700
Medium-temperature brine solution	5	Implementation of new control algorithms and redesigned evaporator to allow chilled brine solution production down to -6°C when ethylene glycol is used (-3°C with propylene glycol)	Covers specific applications such as ice storage and industrial processes	30XB/30XBP 250-1700
Low-temperature brine solution	6	Implementation of new control algorithms and redesigned evaporator to allow chilled brine solution production down to -12°C when ethylene glycol is used (-8°C with propylene glycol)	Covers specific applications such as ice storage and industrial processes	30XB/30XBP 250-1700
Light-brine solution, down to -3°C	8	Implementation of new control algorithms to allow chilled brine solution production down to -3°C when ethylene glycol is used (0°C with propylene glycol)	Matches with most application requirements for ground-sourced heat pumps and fits with many industrial processes requirements	30XB/30XBP 250-1700
Unit equipped for air discharge ducting	10	Fans equipped with discharge connection flanges - maximum available pressure 60 Pa	Facilitates connections to the discharge ducts	30XB/30XBP 250-1700
Low noise level	15	Aesthetic and sound absorbing compressor enclosure	Noise level reduction	30XB/30XBP 250-1700
Very low noise level	15LS	Aesthetic and sound absorbing compressor enclosure associated with low-speed fans	Noise level reduction in sensitive environments	30XB/30XBP 250-1700
Ultra low noise level	15LS+	Acoustic compressor enclosure, low-speed fans and enhanced sound insulation of main noise sources	Noise level reduction in sensitive environments	30XB 250-1700
Variable speed fans	17	Unit equipped with variable speed fans	Enhances the unit seasonal energy efficiency performance and reduces the noise emission thanks to a smooth fan speed variation.	30XB 250-1700
IP54 control box	20A	Increased leak tightness of the unit	Protects the inside of the electrical box from dust, water and sand. In general this option is recommended for installations in polluted environments	30XB/30XBP 250-1700
Tropicalisation of the electrical box	22	Electrical box equipped with an electrical heater and a fan. Electrical connections on the compressors painted with a special varnish and covered with an anti-condensation foam.	Allows safe operation in typical "tropical" climate. This option is recommended for all applications where humidity inside the electrical box can reach 80% at 40°C and unit can remain in stand-by for a long time under these conditions.	30XB/30XBP 250-1700
Grilles and enclosure panels	23	Metal grilles on the 4 unit sides, plus side enclosure panels at each end of each coil	Improves aesthetics, protection against intrusion to the unit interior, coil and piping protection against impacts.	30XB/30XBP 250-1700
Enclosure panels	23A	Side enclosure panels at each end of each coil	Improves aesthetics, coil and piping protection against impacts.	30XB/30XBP 250-1700
Low inrush current	25C	Specific compressor loading and unloading sequence to limit the unit start-up current	Reduced start-up current	30XB/30XBP 250-1700
Winter operation down to -20°C	28	Fan speed control via frequency converter	Stable unit operation for air temperature down to -20°C	30XB 250-1700
Water exchanger frost protection	41A	Electric resistance heater on the water exchanger and discharge valve	Water exchanger frost protection down to -20°C outside temperature	30XB/30XBP 250-1700
Evaporator & hydraulic module frost protection	41B	Electric resistance heater on water exchanger, discharge valve and hydraulic module	Water exchanger and hydraulic module frost protection down to -20°C outside temperature	30XB/30XBP 250-500
Total heat recovery	50	Unit equipped with additional heat exchanger in parallel with the condenser coils.	Production of free hot-water simultaneously with chilled water production	30XB/30XBP 250-1000
Master/slave operation	58	Unit equipped with supplementary water outlet temperature sensor kit (to be field installed) allowing master/slave operation of two units connected in parallel	Optimised operation of two units connected in parallel operation with operating time equalisation	30XB/30XBP 250-1700
Single power connection point	81	Unit power connection via one main supply connection	Quick and easy installation	30XB/30XBP 1100-1550
Service valve set	92	Liquid line valve (evaporator inlet), compressor suction and discharge line valves and economiser line valve	Allow isolation of various refrigerant circuit components for simplified service and maintenance	30XB/30XBP 250-1700
Compressor discharge valves	93A	Shut-off valve on the compressor discharge piping	Simplified maintenance	30XB/30XBP 250-1700
Evaporator with one pass more	100A	Evaporator with one pass more on the water side	Optimise chiller operation when the chilled water circuit is designed with low waterflows (high evaporator delta T)	30XB/30XBP 250-1700
Evaporator with one pass less	100C	Evaporator with one pass less on the water side. Evaporator inlet and outlet on opposite sides.	Easy to install, depending on site. Reduced pressure drops	30XB/30XBP 250-1000
21 bar evaporator	104	Reinforced evaporator for extension of the maximum water-side service pressure to 21 bar (standard 10 bar)	Covers applications with a high water column evaporator side (typically high-rise buildings)	30XB/30XBP 250-1700
Reversed evaporator water connections	107	Evaporator with reversed water inlet/outlet	Easy installation on sites with specific requirements	30XB/30XBP 250-1700
HP single-pump hydraulic module	116B	Complete hydraulic module equipped with water filter, expansion tank with relief valve, one high pressure pump, drain valve and water flow control valve. For more details, refer to the dedicated chapter	Easy and fast installation (plug & play). Increased system reliability	30XB/30XBP 250-500
HP dual-pump hydraulic module	116C	Complete hydraulic module equipped with water filter, expansion tank with relief valve, two high pressure pumps, drain valve and water flow control valve. For more details, refer to the dedicated chapter	Easy and fast installation (plug & play). Increased system reliability	30XB/30XBP 250-500

OPTIONS

Options	No.	Description	Advantages	Use for 30XB / 30XBP
LP single-pump hydraulic module	116F	Complete hydraulic module equipped with water filter, expansion tank with relief valve, one low pressure pump, drain valve and water flow control valve. For more details, refer to the dedicated chapter	Easy and fast installation (plug & play). Increased system reliability	30XB/30XBP 250-500
LP dual-pump hydraulic module	116G	Complete hydraulic module equipped with water filter, expansion tank with relief valve, two low pressure pumps, drain valve and water flow control valve. For more details, refer to the dedicated chapter	Easy and fast installation (plug & play). Increased system reliability	30XB/30XBP 250-500
Dx Free Cooling system on two circuits	118A	Patented Carrier free-cooling system with cooling micro-pump on both refrigerant circuits. Operation without glycol, no extra free-cooling coil. See Dx Free-cooling option chapter	Energy savings for applications with cooling demand throughout the entire year	30XB/30XBP 250-1000
J-Bus gateway	148B	Bi-directional communication board complying with JBus protocol	Connects the unit by communication bus to a building management system	30XB/30XBP 250-1700
Lon gateway	148D	Bi-directional communication board complying with Lon Talk protocol	Connects the unit by communication bus to a building management system	30XB/30XBP 250-1700
Bacnet over IP	149	Bi-directional high-speed communication using BACnet protocol over Ethernet network (IP)	Easy and high-speed connection by ethernet line to a building management system. Allows access to multiple unit parameters	30XB/30XBP 250-1700
Energy Management Module	156	EMM Control board with additional inputs/outputs. See Energy Management Module option chapter	Extended remote control capabilities (Set-point reset, ice storage end, demand limits, boiler on/off command...)	30XB/30XBP 250-1700
7" user interface	158A	Control supplied with a 7 inch colour touch screen user interface	Enhanced ease of use.	30XB/30XBP 250-1700
Input contact for Refrigerant leak detection	159	0-10 V signal to report any refrigerant leakage in the unit directly on the controller (the leak detector itself must be supplied by the customer)	Immediate customer notification of refrigerant losses to the atmosphere, allowing timely corrective actions	30XB/30XBP 250-1700
Dual relief valves on 3-way valve	194	Three-way valve upstream of dual relief valves on the evaporator and the oil separator	Valve replacement and inspection facilitated without refrigerant loss. Comforms to European standard EN378/BGVD4	30XB/30XBP 250-1000
Compliance with Swiss regulations	197	Additional tests on the water heat exchangers: supply (additional of PED documents) supplementary certificates and test certifications	Conformance with Swiss regulations	30XB/30XBP 250-1700
Compliance with Russian regulations	199	EAC certification	Conformance with Russian regulations	30XB/30XBP 250-1700
Compliance with Australian regulations	200	Unit approved to Australian code	Conformance with Australian regulations	30XB/30XBP 250-1700
Power factor correction	231	Capacitors for automatic regulation of power factor (cos phi) value to 0,95.	Reduction of the apparent electrical power, compliance with minimum power factor limit set by utilities	30XB/30XBP 250-1000
Traditional coils (Cu/Al)	254	Coils made of copper tubes with aluminum fins	None	30XB 250-1700 (not available for size 1500)
Traditional coils (Cu/Al) without slots	255	Coils made of copper tubes with aluminum fins without slots	None	30XB 250-1700 (not available for size 1500)
Insulation of the evap. in/out ref. lines	256	Thermal insulation of the evaporator entering/leaving refrigerant lines with flexible, UV resistant insulation	Prevents condensation on the evaporator entering/leaving refrigerant lines	30XB/30XBP 250-1700
Enviro-Shield anti-corrosion protection	262	Coating by conversion process which modifies the surface of the aluminum producing a coating that is integral to the coil. Complete immersion in a bath to ensure 100% coverage. No heat transfer variation, tested 4000 hours salt spray per ASTM B117	Improved corrosion resistance, recommended for use in moderately corrosive environments	30XB/30XBP 250-1700
Super Enviro-Shield anti-corrosion protection	263	Extremely durable and flexible epoxy polymer coating applied on micro channel heat exchangers by electro coating process, final UV protective topcoat. Minimal heat transfer variation, tested 6000 hours constant neutral salt spray per ASTM B117, superior impact resistance per ASTM D2794	Improved corrosion resistance, recommended for use in extremely corrosive environments	30XB/30XBP 250-1700
Welded evaporator connection kit	266	Victaulic pipe adapters for welded joints	Easy installation	30XB/30XBP 250-1700
Compressor enclosure	279a	Compressor enclosure	Improved aesthetic, compressor protection against external elements (dust, sand, water...)	30XB/30XBP 250-1700
Evaporator with aluminum jacket	281	Evaporator covered with an aluminum sheet for thermal insulation protection	Improved resistance to aggressive climate conditions	30XB/30XBP 250-1700
230V electrical plug	284	230V AC power supply source provided with plug socket and transformer (180 VA, 0,8 Amps)	Permits connection of a laptop or an electrical device during unit commissioning or servicing	30XB/30XBP 250-1700
Carrier Connect link (only European distribution companies)	298	3G router board NOTE 1: require option 149 NOTE 2: when more than one machine is installed on site, only one of them shall be equipped with option 298 while all of them must be equipped with option 149 NOTE 3: if the Carrier® PlantCTRL™ is on site, option 298 shall be integrated in the Carrier® PlantCTRL™ while option 149 is still mandatory for each single unit.	Enabler for Carrier Connect service offer	30XB/30XBP 250-1700
Compliance with UAE regulation	318	Additional label on the unit with rated power input, rated current and EER following AHRI 550/590	Compliance with ESMA standard UAE 5010-5 :2014.	30XB/30XBP 250-1700
Compliance with Qatar regulation	319	Specific nameplate on the unit with power supply 415 V+/-6%	Compliance with KAHRAMAA regulation in Qatar.	30XB/30XBP 250-1700

HYDRAULIC MODULE (OPTIONS 116B, C, F, G)

Typical water circuit diagram

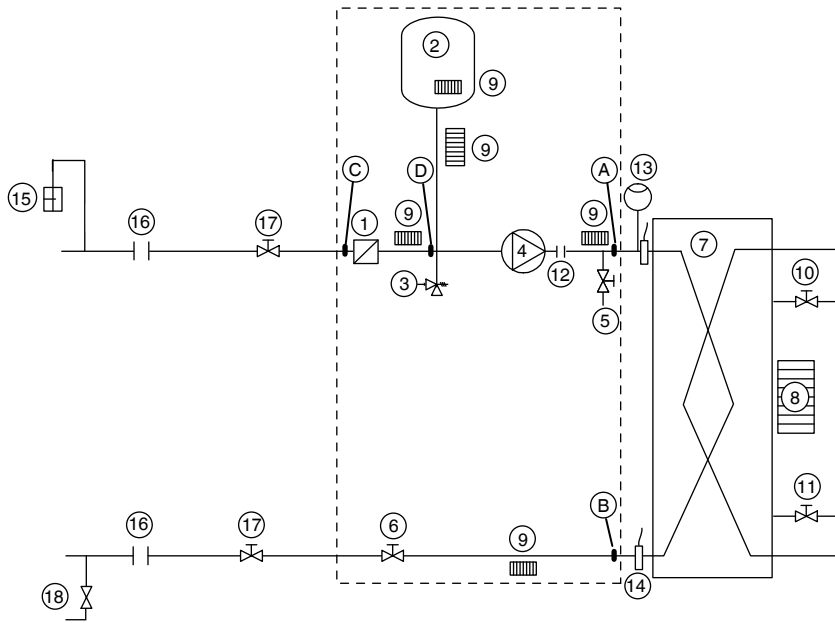

Legend

Components of unit and hydraulic module

- A Pressure sensor (A-B = Δp evaporator)
- B Pressure sensor
- C Pressure sensor (C-D = Δp water filter)
- D Pressure sensor
- 1 Victaulic screen filter
- 2 Expansion tank
- 3 Relief valve
- 4 Water pump
- 5 Drain valve
- 6 Water flow control valve
- 7 Evaporator
- 8 Evaporator defrost heater (option)
- 9 Hydraulic module defrost heater
- 10 Air vent (evaporator)
- 11 Water purge (evaporator)
- 12 Expansion compensator (flexible connections)
- 13 Flow switch
- 14 Water temperature sensor

System components (field-supplied)

- 15 Air vent
- 16 Flexible connection
- 17 Shut-down valves
- 18 Charge valve
- Hydraulic module (option)

ELECTRICAL DATA (OPTIONS 116B, C, F, G)

The pumps that are factory-installed in these units comply with the European Ecodesign directive ErP. The additional electrical data required by regulation 640/2009 is given in the installation, operation and maintenance manual.

This regulation concerns the application of directive 2009/125/EC on the eco-design requirements for electric motors.

PUMP CURVE (OPTIONS 116B, C, F, G)

Conditions and limits of use:

- Fresh water 20°C
- In case of use of the glycol, the maximum water flow is reduced.
- When the glycol is used, it's limited to 40%.

Single pump low pressure

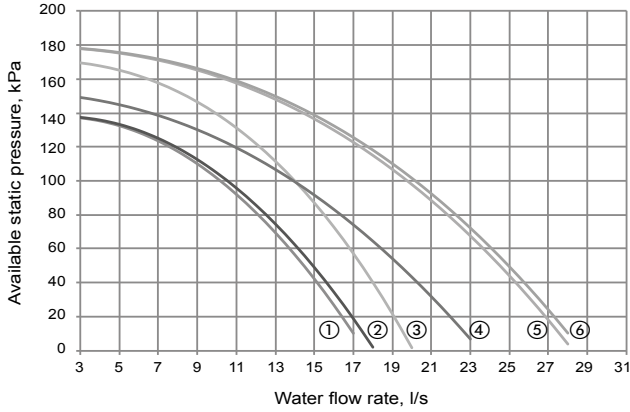

- | | | | |
|---|--------------|---|--------------|
| 1 | 30XB/XBP 250 | 4 | 30XB/XBP 400 |
| 2 | 30XB/XBP 300 | 5 | 30XB/XBP 450 |
| 3 | 30XB/XBP 350 | 6 | 30XB/XBP 500 |

Dual pump low pressure

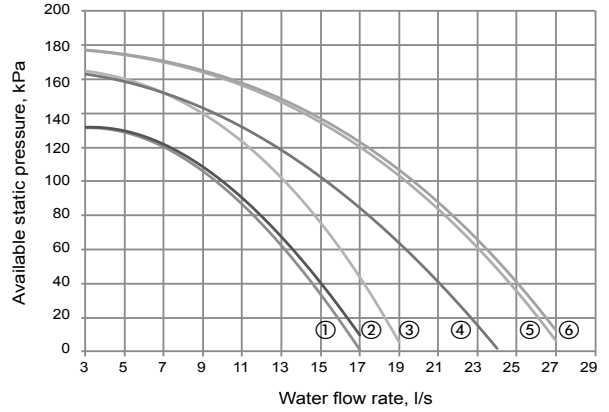

- | | | | |
|---|--------------|---|--------------|
| 1 | 30XB/XBP 250 | 4 | 30XB/XBP 400 |
| 2 | 30XB/XBP 300 | 5 | 30XB/XBP 450 |
| 3 | 30XB/XBP 350 | 6 | 30XB/XBP 500 |

Single pump high pressure

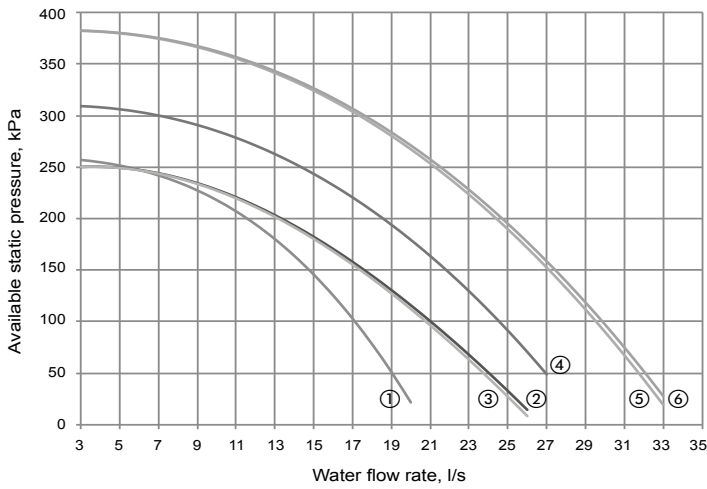

- | | | | |
|---|--------------|---|--------------|
| 1 | 30XB/XBP 250 | 4 | 30XB/XBP 400 |
| 2 | 30XB/XBP 300 | 5 | 30XB/XBP 450 |
| 3 | 30XB/XBP 350 | 6 | 30XB/XBP 500 |

Dual pump high pressure

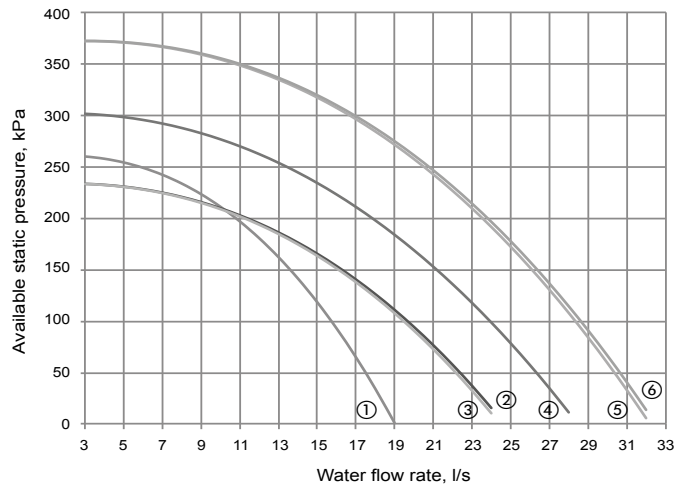

- | | | | |
|---|--------------|---|--------------|
| 1 | 30XB/XBP 250 | 4 | 30XB/XBP 400 |
| 2 | 30XB/XBP 300 | 5 | 30XB/XBP 450 |
| 3 | 30XB/XBP 350 | 6 | 30XB/XBP 500 |

TOTAL HEAT RECLAIM (OPTION 50)

Suitable for heating, domestic hot water production, agriculture and food industry, industrial processes and other hot-water requirements.

With the total heat reclaim option it is possible to reduce the energy consumption bill considerably, when compared to conventional heating equipment such as fossil fuel boilers or electric water tanks.

Operating principle

If hot water production is required, the compressor discharge gases are directed towards the heat reclaim condenser. The refrigerant releases its heat to the hot water that leaves the condenser at a temperature of up to 60°C. In this way 100% of the heat rejected by the liquid chiller can be used to produce hot water. When the demand for heat is satisfied, the hot gas is again directed towards the air condenser where the heat is rejected to the outside air by the fans. Hot water temperature control is ensured by the chiller Touch Pilot control that independently controls the reclaim operation of each refrigerant circuit.

NOTE: Heat reclaim is only possible, possible if the unit is producing cooling at the same time.

Condenser water temperature (°C)	Minimum	Maximum
Entering temperature at start-up	12.5*	55
Entering temperature during operation	20	55
Leaving temperature during operation	25	60
Evaporator water temperature (°C)	Minimum	Maximum
Entering temperature at start-up	-	45
Entering temperature during operation	6.8	21

* The entering water temperature at start-up must not fall below 12.5°C. For installations with a lower temperature a three-way valve must be used.
Note: If the evaporator leaving water temperature is below 4°C, a glycol-water solution or the frost protection option must be used.

In part-load operation, the limitation of the condenser leaving water temperature is due to the operating range of the screw compressor. If the condenser leaving water temperature is above the limit value given in the curves below, the unit will automatically change over to air-cooled operating mode:

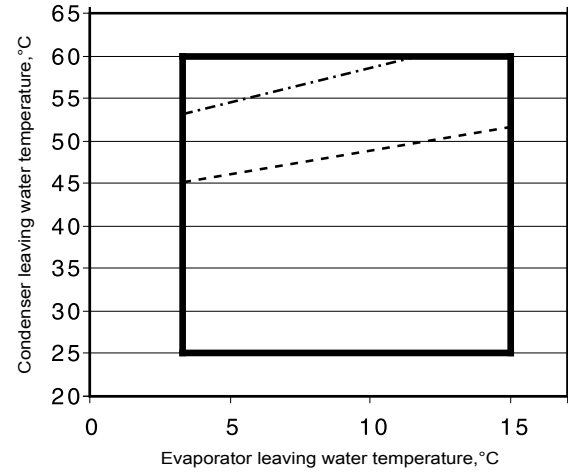

— Full load
 - - - Part load limit, approx. 60%
 - - - Minimum load limit, approx. 30%

Part load operating limits (evaporator leaving water temperature = 7°C)

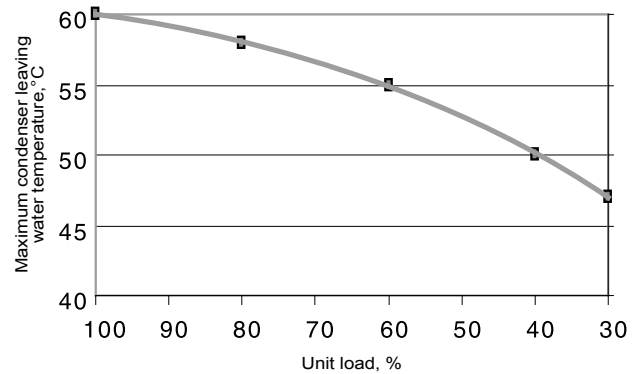

DX FREE COOLING SYSTEM (OPTION 118A)

The DX free cooling option permits significant energy savings for all applications that require cooling in winter. In the free cooling mode the compressors are stopped and only the fan and refrigerant micro-pump are running. The changeover from compressor cooling mode to free cooling mode is automatically controlled by the Touch Pilot control, based on the chiller cooling load and the temperature difference between chilled water and ambient air.

IMPORTANT: In order to optimise chiller performance, it is recommended to use the leaving water set point reset function.

Operating principle

When the chilled water to air temperature difference exceeds a threshold value, the Touch Pilot control carries out a comparison between the instantaneous chiller cooling capacity and the available free cooling capacity. If the operating conditions allow free cooling operation, the compressors are stopped, a set of valves on the suction piping connects the evaporator with the condenser, allowing the migration of the refrigerant gas to the condenser. The refrigerant condenses in the condenser coils, and the refrigerant micro-pump transfers the liquid to the evaporator. The cooling capacity in free cooling mode is controlled by the opening of the electronic expansion valve (EXV).

Operation in combined FC (free-cooling) and MC (mechanical cooling) mode is possible in the two independent refrigerant circuits. This can optimise the free-cooling operation and at the same time ensures that the cooling requirements of the system are met.

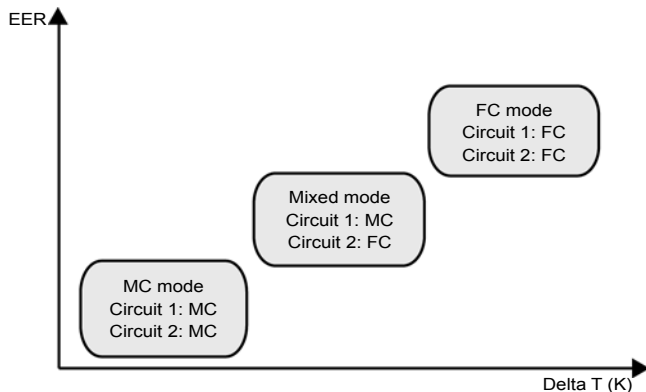

Legend

MC Mechanical cooling (compressors)
FC Free cooling
Delta T Difference between the leaving water temperature and the entering air temperature, K

Advantages of the DX free cooling system

- **Operation without glycol**
 Unlike traditional hydraulic free-cooling systems that require the use of a glycol solution, the Aquaforce DX free cooling chiller works with pure water. The evaporator is protected against frost down to -20°C by an electric resistance heater (option).
- **Low water pressure losses**
 The Aquaforce DX free cooling chiller does not include a three-way valve nor free cooling coils connected in series with the evaporator. The Aquaforce free cooling chiller has the same water pressure losses as a standard chiller.
- **Weight and dimensions gain**
 - The DX free cooling option has practically no impact on the weight of the liquid chiller.
 - The Aquaforce free cooling chiller has the same dimensions as a standard chiller.

- **Increased energy efficiency**
 - In free cooling mode only the fans and the refrigerant micro-pump run. At an air-water temperature difference of 10K, for example, the average chiller energy efficiency (EER) is 23 (kW/kW).
 - In the mechanical cooling mode chiller cooling capacity and efficiency are not compromised by the use of a water-glycol solution.
 - As the pressure losses of the water circuit are low, the water pumps use less energy.

COOLING CAPACITIES

30XB & 30XBP 250 to 1000 in Free Cooling mode (Option 118A)

LWT (10°C)	Condenser entering air temperature, °C					
	0		-5		-10	
	Qc kW	EER kW/kW	Qc kW	EER kW/kW	Qc kW	EER kW/kW
250	143	21,9	183	27,7	186	28,0
300	143	22,3	183	28,3	186	28,5
350	143	22,0	183	27,9	186	28,1
400	183	20,2	255	27,9	275	29,8
450	183	20,0	255	27,7	275	29,6
500	203	19,9	284	27,7	307	29,6
600	253	19,7	373	28,7	416	31,7
700	277	20,2	408	29,5	454	32,6
750	272	19,9	400	29,1	446	32,2
800	275	19,7	405	28,8	451	31,8
850	324	19,9	477	29,1	531	32,2
900	328	20,4	483	29,8	538	32,9
1000	368	20,6	542	30,2	604	33,3

Note: Calculations according to the standard performances (in accordance with EN14511-3:2011) and Eurovent-certified. Evaporator fouling factor 0 m² K/W.

Legend

LWT Leaving water temperature, °C
Qc Cooling capacity, kW
EER Energy efficiency ratio, kW/kW

OPERATING LIMITS

Cooling mode			
Evaporator	Minimum	Maximum	
Entering water temperature at start-up	°C	-	45
Entering water temperature during operation	°C	6,8	21
Leaving water temperature during operation	°C	3,3	15
Condenser (air)	Minimum	Maximum	
Outdoor ambient operating temperature	°C	-10	55*
With winter operation option (option 28)	°C	-20	55*
Free-cooling mode			
Evaporator	Minimum	Maximum	
Entering water temperature at start-up	°C	-	45
Leaving water temperature during operation	°C	3,3	26*
Condenser (air)	Minimum	Maximum	
Outdoor ambient operating temperature	°C	-10	20
With winter operation option (option 28)	°C	-20	20

* Maximum configurable set-point

FAN WITH AVAILABLE PRESSURE (OPTION 10)

This option allows a duct connection at the discharge side of the condenser fan. The unit is equipped with a duct connection frame. The chiller can operate at a static discharge pressure of up to 60 Pa with reduced performance. The performance can be estimated using the coefficients below, applicable at the conditions shown in the curve below.

Selection method

The base performances for the calculation are those of option 119 (only Novation™ MCHE heat exchangers, see pages 24 and 25 of this manual). To obtain the capacities at the static duct pressure, apply the coefficients shown in the table below.

30XB option 10

Fan pressure drop	Pa	Correction factors			
		0	20	40	60
Air flow	%	0	-3,5%	-7,5%	-12,1%
Cooling capacity	%	0	-0,5%	-1,0%	-1,5%
EER	%	0	-1,5%	-3,5%	-5,0%
Power input	%	0	+1,0%	+2,5%	+3,5%

Note: All fans must be individually ducted.

Example

30XB-0800 with 40 Pa pressure drop

Performance at the following conditions:

- 35°C outside air temperature
- 12/7°C entering/leaving water temperature

30XB option 10

		0 Pa	Correction factors	40 Pa
Air flow	l/s	57840	-7,5%	53502
Cooling capacity	kW	788	-1,0%	781
EER	kW/kW	3,14	-3,5%	3,03
Power input	kW	251	2,5%	257

Application limits for correction factors for high air temperatures

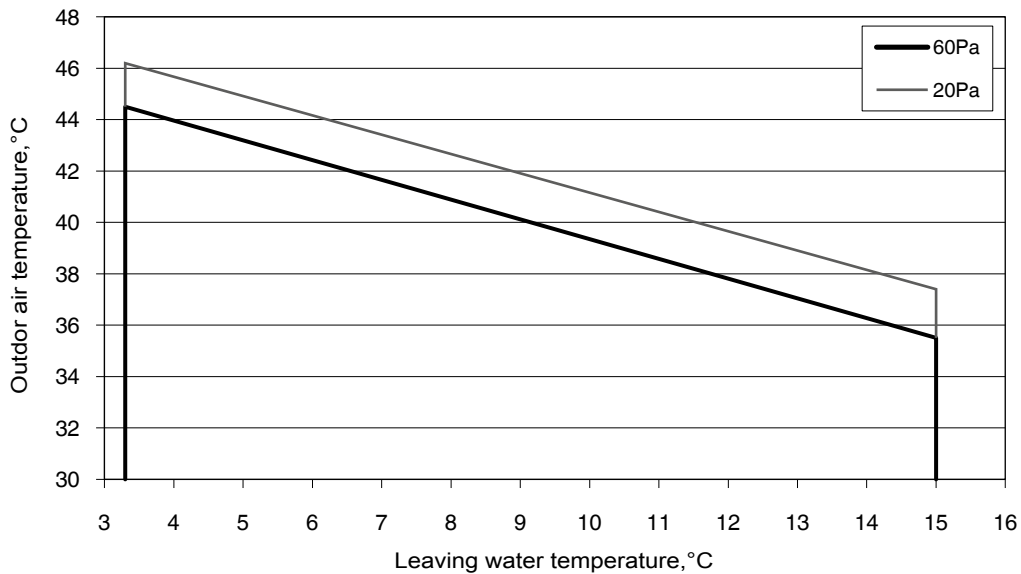

PHYSICAL DATA, SIZES 30XB-250 TO 800

30XB			250	300	350	400	450	500	600	700	750	800		
Cooling														
Standard unit & with option 17			CA1 Nominal capacity	kW	274	299	327	393	444	496	615	682	726	788
Full load performances (*)			CA1 EER	kW/kW	3,14	3,11	3,11	3,22	3,11	3,1	3,15	3,34	3,11	3,14
			CA1 Eurovent class		A	A	A	A	A	A	A	A	A	A
Standard unit			SEER _{12/7°C} Comfort low temp.	kWh/kWh	4,16	4,21	4,27	4,07	4,10	NA	NA	4,31	4,10	4,23
Seasonal energy efficiency			η _{s cool} 12/7°C	%	163	165	168	160	161	NA	NA	169	161	166
			SEER _{23/18°C} Comfort medium temp.	kWh/kWh	4,80	4,79	4,89	4,97	5,02	4,65	4,70	5,02	4,82	-
			SEPR _{12/7°C} Process high temp.	kWh/kWh	4,74	5,15	5,51	4,95	5,33	4,98	5,20	5,50	5,06	5,09
			ESEER	kW/kW	3,87	3,93	4	3,85	3,93	3,76	3,83	4,1	3,88	4,01
Seasonal energy efficiency			SEER _{12/7°C} Comfort low temp.	kWh/kWh										
			η _{s cool} 12/7°C	%										
			SEER _{23/18°C} Comfort medium temp.	kWh/kWh										
			SEPR _{12/7°C} Process high temp.	kWh/kWh										
			ESEER	kW/kW	4,09	4,3	4,13	4,13	4,09	3,84	4,05	4,25	4,03	4,17
Unit with option 15LS (+) / option 15LS (+) & 17			CA1 Nominal capacity	kW	270	294	321	382	430	485	606,9	660,9	698	767
Full load performances (*)			CA1 EER	kW/kW	3,1	3,05	3,07	3,17	2,98	2,93	3,12	3,2	3	2,97
			CA1 Eurovent class		A	B	B	A	B	B	A	A	B	B
Unit with 15LS (+)			SEER _{12/7°C} Comfort low temp.	kWh/kWh	4,30	4,34	4,54	4,34	4,25	4,15	4,11	4,38	4,10	4,11
Seasonal energy efficiency			η _{s cool} 12/7°C	%	169	171	179	171	167	163	162	172	161	162
			SEER _{23/18°C} Comfort medium temp.	kWh/kWh	4,79	4,79	5,06	5,23	5,16	4,75	4,73	4,95	4,83	-
			SEPR _{12/7°C} Process high temp.	kWh/kWh	5,03	5,24	5,98	5,17	5,50	5,13	5,66	5,69	5,40	5,52
			ESEER	kW/kW	3,98	4,24	4,22	4,14	4,17	3,92	4,12	4,13	4,05	4,1
Unit with Option 17 & 15LS (+)			SEER _{12/7°C} Comfort low temp.	kWh/kWh										
Seasonal energy efficiency			η _{s cool} 12/7°C	%										
			SEER _{23/18°C} Comfort medium temp.	kWh/kWh										
			SEPR _{12/7°C} Process high temp.	kWh/kWh										
			ESEER	kW/kW	4,03	4,29	4,24	4,19	4,18	4,14	4,14	4,16	4,06	4,12
Sound levels														
Standard unit														
Sound power ⁽¹⁾			dB(A)	99	99	99	99	101	99	101	99	103	103	
Sound pressure at 10 m ⁽²⁾			dB(A)	67	67	67	67	69	67	68	67	70	70	
Unit + option 15⁽³⁾														
Sound power ⁽¹⁾			dB(A)	93	93	94	95	95	95	97	96	97	98	
Sound pressure at 10 m ⁽²⁾			dB(A)	61	61	62	63	63	63	65	63	64	65	
Unit + option 15LS⁽³⁾														
Sound power ⁽¹⁾			dB(A)	87	87	87	90	91	91	93	92	94	94	
Sound pressure at 10 m ⁽²⁾			dB(A)	54	54	54	57	58	58	59	58	60	60	
Unit + option 15LS+⁽³⁾														
Sound power ⁽¹⁾			dB(A)	-	-	-	-	89	89	91	90	91	92	
Sound pressure at 10 m ⁽²⁾			dB(A)	-	-	-	-	56	56	57	56	58	58	
Dimensions														
Standard unit														
Length			mm	3604	3604	3604	4798	4798	4798	7186	7186	7186	7186	
Width			mm	2253	2253	2253	2253	2253	2253	2253	2253	2253		
Height			mm	2297	2297	2297	2297	2297	2297	2297	2297	2297		

(*) In accordance with standard EN14511-3:2013.
 CA1 Cooling mode conditions: Evaporator water entering/leaving temperature 12°C/7°C, outside air temperature 35°C, evaporator frosting factor 0 m².K/W
 η_{s cool} 12/7°C & SEPR Réglementation Ecodesign applicable (UE) No 2016/2281
 (1) In dB ref=10⁻¹² W, 'A' weighted. Declared dual-number noise emission values in accordance with ISO 4871 with an associated uncertainty of +/-3dB(A). Measured in accordance with ISO 9614-1 and certified by Eurovent.
 (2) In dB ref 20μPa, 'A' weighted. Declared dual-number noise emission values in accordance with ISO 4871 with an associated uncertainty of +/-3dB(A). For information, calculated from the sound power Lw(A).
 (3) Options : 15 = Low noise, 15LS = Very Low noise, 118a = Dx freecooling option, 50= heat recovery.



PHYSICAL DATA, SIZES 30XB-250 TO 800

30XB		250	300	350	400	450	500	600	700	750	800
Operating weight⁽⁴⁾											
Standard unit	kg	3025	3059	3080	3669	3734	3802	4797	4928	5211	5522
Unit + option 15 ⁽³⁾	kg	3293	3327	3348	3968	4033	4101	5128	5259	5542	5853
Unit + option 118a ⁽³⁾	kg	3109	3143	3164	3773	3838	4186	4929	5060	5358	5669
Unit + option 50 ⁽³⁾	kg	3370	3404	3425	4102	4245	4601	5551	5782	6065	6382
Compressors											
06T semi-hermetic screw compressor, 50 r/s											
Circuit A		1	1	1	1	1	1	1	1	1	1
Circuit B		1	1	1	1	1	1	1	1	1	1
No. of control stages											
Refrigerant⁽⁴⁾											
R134a											
Circuit A	kg	37	35	35	51	52	54	58	58	65	69
	teqCO ₂	52,9	50,1	50,1	72,2	74,4	76,5	82,9	82,9	93,0	98,7
Circuit B	kg	39	36	37	37	37	33	59	62	58	65
	teqCO ₂	55,1	51,5	52,9	52,2	52,9	46,5	84,4	88,7	82,9	93,0
Oil											
Circuit A	l	20,8	20,8	20,8	23,5	23,5	23,5	23,5	23,5	27,6	27,6
Circuit B	l	20,8	20,8	20,8	20,8	20,8	20,8	23,5	23,5	23,5	23,5
Capacity control		Touch Pilot, , Electronic Expansion Valve (EXV)									
Minimum capacity	%	15	15	15	15	15	15	15	15	15	15
Air heat exchanger											
Aluminum micro-channel coils (MCHE)											
Fans											
FLYING-BIRD 6, axial fan with rotating impeller											
Standard unit											
Quantity		6	6	6	8	8	8	11	12	12	12
Maximum total air flow	l/s	28920	28920	28920	38560	38560	38560	53020	57840	57840	57840
Maximum rotation speed	r/s	15,7	15,7	15,7	15,7	15,7	15,7	15,7	15,7	15,7	15,7
Unit + option 15LS											
Maximum total air flow	l/s	23580	23580	23580	31440	31440	31440	43230	47160	47160	47160
Maximum rotation speed	r/s	11,7	11,7	11,7	11,7	11,7	11,7	11,7	11,7	11,7	11,7
Water heat exchanger											
Flooded multi-tube type											
Water volume	l	58	61	61	66	70	77	79	94	98	119
Max. water-side operating pressure without hydraulic module	kPa	1000	1000	1000	1000	1000	1000	1000	1000	1000	1000
Hydraulic module (option)											
Pump, Victaulic screen filter, relief valve, water and air drain valve, pressure sensors, expansion tank (option)											
Pump		Centrifugal pump, monocoil, 48,3r/s, low or high pressure (as required), single or dual (as required)									
Expansion vessel volume	l	50	50	50	50	50	80				
Max. water-side operating pressure with hydraulic module	kPa	400	400	400	400	400	400				
Water connections without or with hydraulic module											
Victaulic® type											
Connections	inch	5 or 4	5 or 4	5 or 4	5 or 4	5 or 4	5 or 4	5	6	6	6
External diameter ⁽⁵⁾	mm	114,3 or 141,3	114,3 or 141,3	114,3 or 141,3	114,3 or 141,3	114,3 or 141,3	114,3 or 141,3	141,3	168,3	168,3	168,3
Casing paint											
Colour code RAL 7035											

(3) Options : 15 = Low noise, 15LS = Very Low noise, 118a = Dx freecooling option, 50= heat recovery.

(4) Values are guidelines only. Refer to the unit name plate.

(5) Depends of options

PHYSICAL DATA, SIZES 30XB-850 TO 1700

30XB			850	900	1000	1100	1200	1300	1400	1500	1550	1700	
Cooling													
Standard unit & with option 17	CA1 Nominal capacity	kW	828	890	965	1126	1244	1332	1440	1492	1532	1689	
	Full load performances (*)	CA1 EER	kW/kW	3,13	3,13	2,97	3,08	3,1	3,18	3,08	3,12	3,23	3,25
		CA1 Eurovent class		A	A	B	B	A	A	B	A	A	A
Standard unit	SEER _{12/7°C} Comfort low temp.	kWh/kWh	NA	4,17	NA	4,10	4,22	NA	4,14	4,10	4,24	4,12	
	Seasonal energy efficiency	ηs cool _{12/7°C}	%	NA	164	NA	161	166	NA	163	161	167	162
		SEER _{23/18°C} Comfort medium temp.	kWh/kWh	4,61	4,66	4,36	4,78	4,91	4,64	4,68	4,78	-	-
		SEPR _{12/7°C} Process high temp.	kWh/kWh	5,17	5,08	5,13	5,31	5,46	5,33	5,43	5,11	5,31	5,24
		ESEER	kW/kW	3,87	3,98	3,75	3,91	4,13	3,88	3,92	3,84	4,02	3,91
Seasonal energy efficiency	SEER _{12/7°C} Comfort low temp.	kWh/kWh											
		ηs cool _{12/7°C}	%										
	Unit with Option 17	SEER _{23/18°C} Comfort medium temp.	kWh/kWh										
		SEPR _{12/7°C} Process high temp.	kWh/kWh										
			ESEER	kW/kW	3,96	4,16	3,81	3,97	4,16	4,09	3,94	3,84	
Unit with option 15LS (+) / option 15LS (+) & 17	CA1 Nominal capacity	kW	775	859	929	1111	1211	1298	1391	1418	1457	1627	
	Full load performances (*)	CA1 EER	kW/kW	2,8	2,97	2,96	2,9	3,03	2,9	2,77	2,94	2,96	3,1
		CA1 Eurovent class		C	B	B	B	B	C	B			
Unit with 15LS (+)	SEER _{12/7°C} Comfort low temp.	kWh/kWh	NA	4,11	NA	NA	NA	NA	NA	NA	4,14	NA	
	Seasonal energy efficiency	ηs cool _{12/7°C}	%	NA	161	NA	NA	NA	NA	NA	163	NA	
		SEER _{23/18°C} Comfort medium temp.	kWh/kWh	4,47	4,56	-	4,49	-	4,12	4,19	4,42	-	-
		SEPR _{12/7°C} Process high temp.	kWh/kWh	5,23	5,37	5,31	5,10	5,34	4,98	4,93	NA	5,39	5,23
		ESEER	kW/kW	3,74	3,86	3,73	3,74	4,06	3,56	3,49	3,67	3,9	3,86
Unit with Option 17 & 15LS (+)	SEER _{12/7°C} Comfort low temp.	kWh/kWh											
	Seasonal energy efficiency	ηs cool _{12/7°C}	%										
		SEER _{23/18°C} Comfort medium temp.	kWh/kWh										
		SEPR _{12/7°C} Process high temp.	kWh/kWh										
		ESEER	kW/kW	4,16	3,85	3,86	3,96	4,16	3,73	3,60	3,50		
Sound levels													
Standard unit													
	Sound power ⁽¹⁾	dB(A)	101	104	102	103	102	104	104	104	104	104	
	Sound pressure at 10 m ⁽²⁾	dB(A)	70	71	69	70	69	71	71	71	71	70	
Unit + option 15⁽³⁾													
	Sound power ⁽¹⁾	dB(A)	97	99	98	98	98	100	99	99	100	100	
	Sound pressure at 10 m ⁽²⁾	dB(A)	65	66	65	65	65	67	65	65	67	66	
Unit + option 15LS⁽³⁾													
	Sound power ⁽¹⁾	dB(A)	94	95	94	94	94	99	95	96	96	96	
	Sound pressure at 10 m ⁽²⁾	dB(A)	60	62	65	65	61	65	61	-1	61	61	
Unit + option 15LS+⁽³⁾													
	Sound power ⁽¹⁾	dB(A)	91	93	92	93	93	97	94	95	93	93	
	Sound pressure at 10 m ⁽²⁾	dB(A)	58	60	59	60	60	66	61	62	60	60	
Dimensions													
Standard unit													
	Length	mm	7186	7186	8380	9574	10770	11962	11962	13157	9574/ 4798	8380/ 8380	
	Width	mm	2253	2253	2253	2253	2253	2253	2253	2253	2253	2253	
	Height	mm	2297	2297	2297	2297	2297	2297	2297	2297	2297	2297	

(*) In accordance with standard EN14511-3:2013.
 CA1 Cooling mode conditions: Evaporator water entering/leaving temperature 12°C/7°C, outside air temperature 35°C, evaporator frosting factor 0 m².K/W
 ηs cool_{12/7°C} & SEPR Réglementation Ecodesign applicable (UE) No 2016/2281
 (1) In dB ref=10⁻¹² W, 'A' weighted. Declared dual-number noise emission values in accordance with ISO 4871 with an associated uncertainty of +/-3dB(A). Measured in accordance with ISO 9614-1 and certified by Eurovent.
 (2) In dB ref 20µPa, 'A' weighted. Declared dual-number noise emission values in accordance with ISO 4871 with an associated uncertainty of +/-3dB(A). For information, calculated from the sound power Lw(A).
 (3) Options : 15 = Low noise, 15LS = Very Low noise, 118a = Dx freecooling option, 50= heat recovery.



PHYSICAL DATA, SIZES 30XB-850 TO 1700

30XB		850	900	1000	1100	1200	1300	1400	1500	1550	1700
Operating weight⁽⁴⁾											
Standard unit	kg	5570	5848	6318	7292	7755	8625	8702	9016	3422/ 6714	5957/ 5957
Unit + option 15 ⁽³⁾	kg	5901	6179	6649	7663	8126	8997	9074	9388	3588/ 7046	6288/ 6288
Unit + option 118 ⁽³⁾	kg	6004	6302	6771	-	-	-	-	-	-	-
Unit + option 50 ⁽³⁾	kg	6430	6805	7272	-	-	-	-	-	-	-
Compressors											
06T semi-hermetic screw compressor, 50 r/s											
Circuit A		1	1	1	1	1	1	1	1	1	1
Circuit B		1	1	1	1	1	1	1	1	1	1
Circuit C										1	1
Circuit D											1
No. of control stages											
Refrigerant⁽⁴⁾											
R134a											
Circuit A	kg	69	67	71	76	76	110	116	132	85	72
	teqCO ₂	98,7	95,8	100,8	108,7	108,7	157,3	165,9	188,8	121,6	103,0
Circuit B	kg	65	67	72	108	120	116	124	120	88	63
	teqCO ₂	93,0	95,8	103,0	154,4	171,6	165,9	177,3	171,6	125,8	90,1
Circuit C	kg									80,0	72,0
	teqCO ₂									114,4	103,0
Circuit D	kg										63,0
	teqCO ₂										90,1
Oil											
Oil type											
Circuit A	l	27,6	27,6	27,6	27,6	27,6	36,0	36,0	36,0	27,6	27,6
Circuit B	l	23,5	27,6	27,6	36,0	36,0	36,0	36,0	36,0	27,6	23,5
Circuit C	l									27,6	27,6
Circuit D	l										23,5
Capacity control											
Touch Pilot, Electronic Expansion Valve (EXV)											
Minimum capacity	%	15	15	15	15	15	15	15	15	10	8
Air heat exchanger											
Aluminum micro-channel coils (MCHE)											
Fans											
FLYING-BIRD 6, axial fan with rotating impeller											
Standard unit											
Quantity		12	12	14	16	18	20	20	22	24	28
Maximum total air flow	l/s	57840	57840	67480	77120	86760	96400	96400	106040	115680	134960
Maximum rotation speed	r/s	15,7	15,7	15,7	15,7	15,7	15,7	15,7	15,7	15,7	15,7
Unit + option 15LS											
Maximum total air flow	l/s	47160	47160	55020	62880	70740	78600	78600	86460	94320	110040
Maximum rotation speed	r/s	11,7	11,7	11,7	11,7	11,7	11,7	11,7	11,7	11,7	11,7
Water heat exchanger											
Flooded multi-tube type											
Water volume	l	119	130	140	164	174	180	189	189	240	240
Max. water-side operating pressure without hydraulic module	kPa	1000	1000	1000	1000	1000	1000	1000	1000	1000	1000
Water connections without or with hydraulic module											
Victaulic® type											
Connections	inch	6	6	6	6	6	6	6	6	8/6	6
External diameter ⁽⁵⁾	mm	168,3	168,3	168,3	168,3	168,3	168,3	168,3	168,3	219,1/ 168,3	168,3
Casing paint											
Colour code RAL 7035											

(3) Options : 15 = Low noise, 15LS = Very Low noise, 118a = Dx freecooling option, 50= heat recovery.

(4) Values are guidelines only. Refer to the unit name plate.

(5) Depends of options

PHYSICAL DATA, SIZES 30XBP-250 TO 800

30XBP		250	300	350	400	450	500	600	700	750	800	
Cooling												
Standard unit	CA1 Nominal capacity	kW	274	299	327	394	444	501	615	682	727	789
Full load performances (*)	CA1 EER	kW/kW	3,22	3,19	3,15	3,32	3,13	3,22	3,23	3,34	3,17	3,19
	CA1 Eurovent class		A	A	A	A	A	A	A	A	A	A
Seasonal energy efficiency	SEER _{12/7°C} Comfort low temp.	kWh/kWh	4,50	4,57	4,55	4,51	4,36	4,52	4,23	4,65	4,30	4,55
	ηs cool _{12/7°C}	%	176,8	179,6	179,1	177,3	171,4	177,7	166,2	182,8	169,0	178,8
	SEER _{23/18°C} Comfort medium temp.	kWh/kWh	5,16	5,16	5,18	5,45	5,35	5,32	4,98	5,37	5,13	-
	SEPR _{12/7°C} Process high temp.	kWh/kWh	6,06	6,22	6,34	5,93	5,88	6,05	5,81	6,30	5,68	5,74
	ESEER	kW/kW	4,2	4,43	4,27	4,26	4,23	4,27	4,19	4,4	4,16	4,32
Unit with Option 15LS	CA1 Nominal capacity	kW	270	294	321	382	430	478	607	661	698	767
Full load performances (*)	CA1 EER	kW/kW	3,12	3,1	3,11	3,2	2,99	3,04	3,14	3,22	3,01	2,99
	CA1 Eurovent class		A	A	A	A	B	B	A	A	B	B
Seasonal energy efficiency	SEER _{12/7°C} Comfort low temp.	kWh/kWh	4,43	4,55	4,69	4,48	4,37	4,46	4,27	4,53	4,22	4,23
	ηs cool _{12/7°C}	%	174	179	185	176	172	175	168	178	166	166
	SEER _{23/18°C} Comfort medium temp.	kWh/kWh	5,02	5,04	5,20	5,41	5,31	5,18	4,90	5,10	4,97	-
	SEPR _{12/7°C} Process high temp.	kWh/kWh	5,93	6,15	6,45	5,88	5,81	5,88	5,97	6,19	5,65	5,75
	ESEER	kW/kW	4,12	4,43	4,36	4,29	4,29	4,24	4,27	4,27	4,16	4,23
Sound levels												
Standard unit												
Sound power ⁽¹⁾		dB(A)	99	99	99	99	101	99	101	99	103	103
Sound pressure at 10 m ⁽²⁾		dB(A)	67	67	67	67	69	67	68	67	70	70
Unit + option 15⁽³⁾												
Sound power ⁽¹⁾		dB(A)	93	93	94	95	95	95	97	96	97	98
Sound pressure at 10 m ⁽²⁾		dB(A)	61	61	62	63	63	63	65	63	64	65
Unit + option 15LS⁽³⁾												
Sound power ⁽¹⁾		dB(A)	87	87	87	90	91	91	93	92	94	94
Sound pressure at 10 m ⁽²⁾		dB(A)	55	55	55	58	59	59	60	59	61	61
Unit + option 15LS+⁽³⁾												
Sound power ⁽¹⁾		dB(A)	-	-	-	-	-	-	-	-	-	-
Sound pressure at 10 m ⁽²⁾		dB(A)	-	-	-	-	-	-	-	-	-	-
Dimensions												
Standard unit												
Length		mm	3604	3604	3604	4798	4798	5992	7186	7186	7186	7186
Width		mm	2253	2253	2253	2253	2253	2253	2253	2253	2253	2253
Height		mm	2297	2297	2297	2297	2297	2297	2297	2297	2297	2297
Operating weight⁽⁴⁾												
Standard unit		kg	3190	3224	3245	3834	3899	4261	4962	5093	5376	5687
Unit + option 15 ⁽³⁾		kg	3458	3492	3513	4133	4198	4560	5293	5424	5707	6018
Compressors												
06T semi-hermetic screw compressor, 50 r/s												
Circuit A			1	1	1	1	1	1	1	1	1	1
Circuit B			1	1	1	1	1	1	1	1	1	1
No. of control stages												
Refrigerant⁽⁴⁾												
R134a												
Circuit A		kg	37,0	35,0	35,0	50,5	52,0	53,5	58,0	58,0	65,0	69,0
		teqCO ₂	52,9	50,1	50,1	72,2	74,4	76,5	82,9	82,9	93,0	98,7
Circuit B		kg	38,5	36	37	36,5	37	32,5	59	62	58	65
		teqCO ₂	55,1	51,5	52,9	52,2	52,9	46,5	84,4	88,7	82,9	93,0

(*) In accordance with standard EN14511-3:2013.

CA1 Cooling mode conditions: Evaporator water entering/leaving temperature 12°C/7°C, outside air temperature 35°C, evaporator fouling factor 0 m².K/W

ηs cool_{12/7°C} & SEPR Réglementation Ecodesign applicable (UE) No 2016/2281

(1) In dB ref=10⁻¹² W, 'A' weighted. Declared dual-number noise emission values in accordance with ISO 4871 with an associated uncertainty of +/-3dB(A). Measured in accordance with ISO 9614-1 and certified by Eurovent.

(2) In dB ref 20μPa, 'A' weighted. Declared dual-number noise emission values in accordance with ISO 4871 with an associated uncertainty of +/-3dB(A). For information, calculated from the sound power Lw(A).

(3) Options : 15 = Low noise, 15LS = Very Low noise, 118a = Dx freecooling option, 50= heat recovery.

(4) Values are guidelines only. Refer to the unit name plate.



Valeurs certifiées Eurovent

PHYSICAL DATA, SIZES 30XBP-250 TO 800

30XBP		250	300	350	400	450	500	600	700	750	800
Oil											
Circuit A	l	20,8	20,8	20,8	23,5	23,5	23,5	23,5	23,5	27,6	27,6
Circuit B	l	20,8	20,8	20,8	20,8	20,8	20,8	23,5	23,5	23,5	23,5
Capacity control											
Touch Pilot, , Electronic Expansion Valve (EXV)											
Minimum capacity	%	15	15	15	15	15	15	15	15	15	15
Air heat exchanger											
Aluminum micro-channel coils (MCHE)											
Fans											
FLYING-BIRD 6, axial fan with rotating impeller											
Standard unit											
Quantity		6	6	6	8	8	9	11	12	12	12
Maximum total air flow	l/s	28920	28920	28920	38560	38560	43380	53020	57840	57840	57840
Maximum rotation speed	r/s	15,7	15,7	15,7	15,7	15,7	15,7	15,7	15,7	15,7	15,7
Unit + option 15LS											
Maximum total air flow	l/s	23580	23580	23580	31440	31440	35370	43230	47160	47160	47160
Maximum rotation speed	r/s	11,7	11,7	11,7	11,7	11,7	11,7	11,7	11,7	11,7	11,7
Water heat exchanger											
Flooded multi-tube type											
Water volume	l	58	61	61	66	70	77	79	94	98	119
Max. water-side operating pressure without hydraulic module	kPa	1000	1000	1000	1000	1000	1000	1000	1000	1000	1000
Hydraulic module (option)											
Pump, Victaulic screen filter, relief valve, water and air drain valve, pressure sensors, expansion tank (option)											
Pump											
Centrifugal pump, monocell, 48,3r/s, low or high pressure (as required), single or dual (as required)											
Expansion vessel volume	l	50	50	50	50	50	80				
Max. water-side operating pressure with hydraulic module	kPa	400	400	400	400	400	400				
Water connections without or with hydraulic module											
Victaulic® type											
Connections	inch	5 or 4	5 or 4	5 or 4	5 or 4	5 or 4	5 or 4	5	6	6	6
External diameter ⁽⁵⁾	mm	114,3 or 141,3	114,3 or 141,3	114,3 or 141,3	114,3 or 141,3	114,3 or 141,3	114,3 or 141,3	141,3	168,3	168,3	168,3
Casing paint											
Colour code RAL 7035											

(5) Depends of options

PHYSICAL DATA, SIZES 30XB-850 TO 1500

30XB			850	900	1000	1100	1200	1300	1400	1500
Cooling										
Standard unit	CA1 Nominal capacity	kW	845	890	980	1150	1253	1333	1440	1493
Full load performances (*)	CA1 EER	kW/kW	3,32	3,19	3,2	3,36	3,3	3,22	3,12	3,19
	CA1 Eurovent class		A	A	A	A	A	A	A	A
Seasonal energy efficiency	SEER _{12/7°C} Comfort low temp.	kWh/kWh	4,63	4,28	4,21	4,56	4,57	4,27	4,31	4,10
	ηs cool _{12/7°C}	%	182	168	165	179	180	168	169	161
	SEER _{23/18°C} Comfort medium temp.	kWh/kWh	5,42	4,94	4,83	5,41	5,30	4,80	4,87	4,92
	SEPR _{12/7°C} Process high temp.	kWh/kWh	5,96	5,76	5,65	5,93	5,91	5,73	5,67	5,49
	ESEER	kW/kW	4,39	4,03	3,99	4,37	4,44	4,21	4,05	3,97
Unit with Option 15LS	CA1 Nominal capacity	kW	815	884	976	1118	1230	1298	1391	1443
Full load performances (*)	CA1 EER	kW/kW	3,1	3,02	3,06	3,12	3,16	2,97	2,83	2,94
	CA1 Eurovent class		A	B	B	A	A	B	C	B
Seasonal energy efficiency	SEER _{12/7°C} Comfort low temp.	kWh/kWh	4,53	4,18	4,20	4,26	4,38	NA	NA	4,27
	ηs cool _{12/7°C}	%	178	164	165	167	172	NA	NA	168
	SEER _{23/18°C} Comfort medium temp.	kWh/kWh	5,21	4,71	-	5,02	-	4,48	4,44	4,61
	SEPR _{12/7°C} Process high temp.	kWh/kWh	5,85	5,68	5,72	5,57	5,68	5,34	5,30	5,48
	ESEER	kW/kW	4,3	3,93	3,96	4,07	4,25	3,89	3,72	3,88
Sound levels										
Standard unit										
Sound power ⁽¹⁾		dB(A)	101	104	102	103	102	104	104	104
Sound pressure at 10 m ⁽²⁾		dB(A)	70	71	69	70	69	71	71	71
Unit + option 15⁽³⁾										
Sound power ⁽¹⁾		dB(A)	97	99	98	98	98	100	99	99
Sound pressure at 10 m ⁽²⁾		dB(A)	65	66	65	65	65	67	65	65
Unit + option 15LS⁽³⁾										
Sound power ⁽¹⁾		dB(A)	94	95	94	94	94	99	95	96
Sound pressure at 10 m ⁽²⁾		dB(A)	61	62	61	61	61	66	62	63
Unit + option 15LS+⁽³⁾										
Sound power ⁽¹⁾		dB(A)	-	-	-	-	-	-	-	-
Sound pressure at 10 m ⁽²⁾		dB(A)	-	-	-	-	-	-	-	-
Dimensions										
Standard unit										
Length		mm	8380	8380	9574	11962	11962	11962	11962	13157
Width		mm	2253	2253	2253	2253	2253	2253	2253	2253
Height		mm	2297	2297	2297	2297	2297	2297	2297	2297
Operating weight⁽⁴⁾										
Standard unit		kg	6072	6376	6827	8070	8211	8790	8867	9181
Unit + option 15 ⁽³⁾		kg	6403	6707	7158	8441	8582	9162	9239	9553
Compressors										
06T semi-hermetic screw compressor, 50 r/s										
Circuit A			1	1	1	1	1	1	1	1
Circuit B			1	1	1	1	1	1	1	1
No. of control stages										
Refrigerant⁽⁴⁾										
R134a										
Circuit A		kg	72	69	75	76	76	110	116	132
		teqCO ₂	103,0	98,7	107,3	108,7	108,7	157,3	165,9	188,8
Circuit B		kg	63	76	79	108	120	116	124	120
		teqCO ₂	90,1	108,7	113,0	154,4	171,6	165,9	177,3	171,6

(*) In accordance with standard EN14511-3:2013.

CA1 Cooling mode conditions: Evaporator water entering/leaving temperature 12°C/7°C, outside air temperature 35°C, evaporator fouling factor 0 m².K/W

ηs cool_{12/7°C} & SEPR Réglementation Ecodesign applicable (UE) No 2016/2281

(1) In dB ref=10⁻¹² W, 'A' weighted. Declared dual-number noise emission values in accordance with ISO 4871 with an associated uncertainty of +/-3dB(A). Measured in accordance with ISO 9614-1 and certified by Eurovent.

(2) In dB ref 20μPa, 'A' weighted. Declared dual-number noise emission values in accordance with ISO 4871 with an associated uncertainty of +/-3dB(A). For information, calculated from the sound power Lw(A).

(3) Options : 15 = Low noise, 15LS = Very Low noise, 118a = Dx freecooling option, 50= heat recovery.

(4) Values are guidelines only. Refer to the unit name plate.



Valeurs certifiées Eurovent

PHYSICAL DATA, SIZES 30XB-850 TO 1700

30XB		850	900	1000	1100	1200	1300	1400	1500
Oil									
Circuit A	l	27,6	27,6	27,6	27,6	27,6	36,0	36,0	36,0
Circuit B	l	23,5	27,6	27,6	36,0	36,0	36,0	36,0	36,0
Capacity control									
Touch Pilot, , Electronic Expansion Valve (EXV)									
Minimum capacity	%	15	15	15	15	15	15	15	15
Air heat exchanger									
Aluminum micro-channel coils (MCHE)									
Fans									
FLYING-BIRD 6, axial fan with rotating impeller									
Standard unit									
Quantity		14	14	16	20	20	20	20	22
Maximum total air flow	l/s	67480	67480	77120	96400	96400	96400	96400	106040
Maximum rotation speed	r/s	15,7	15,7	15,7	15,7	15,7	15,7	15,7	15,7
Unit + option 15LS									
Maximum total air flow	l/s	55020	55020	62880	78600	78600	78600	78600	86460
Maximum rotation speed	r/s	11,7	11,7	11,7	11,7	11,7	11,7	11,7	11,7
Water heat exchanger									
Flooded multi-tube type									
Water volume	l	119	130	140	164	174	180	189	189
Max. water-side operating pressure without hydraulic module	kPa	1000	1000	1000	1000	1000	1000	1000	1000
Hydraulic module (option)									
Pump, Victaulic screen filter, relief valve, water and air drain valve, pressure sensors, expansion tank (option)									
Pump		Centrifugal pump, monocell, 48,3r/s, low or high pressure (as required), single or dual (as required)							
Expansion vessel volume	l								
Max. water-side operating pressure with hydraulic module	kPa								
Water connections without or with hydraulic module									
Victaulic® type									
Connections	inch	6	6	8	6	6	6	6	6
External diameter ⁽⁵⁾	mm	168,3	168,3	219,1	168,3	168,3	168,3	168,3	168,3
Casing paint									
Colour code RAL 7035									

(5) Depends of options

ELECTRICAL DATA, 30XB-250 TO 1000

30XB 30XBP		250	300	350	400	450	500	600	700	750	800	850	900	1000	
Power circuit supply															
Nominal voltage	V-ph-Hz	400-3-50													
Voltage range	V	360-440													
Control circuit supply		24 V via internal transformer													
Maximum operating input power⁽¹⁾ - 30XB															
Standard unit	kW	119	133	147	168	195	214	264	285	319	338	367	392	454	
Unit + option 15LS	kW	112	126	140	159	185	204	251	271	305	324	353	378	437	
Maximum operating input power⁽¹⁾ - 30XBP															
Standard unit	kW	117	131	145	165	192	211	259	279	314	333	362	386	447	
Unit + option 15LS	kW	114	127	141	160	187	206	252	272	306	325	354	379	438	
Power factor at maximum power⁽¹⁾ - 30XB															
Standard unit															
Displacement Power Factor (Cos Phi)		0,88	0,88	0,88	0,88	0,89	0,89	0,89	0,89	0,89	0,89	0,89	0,90	0,90	
Unit + option 15LS															
Displacement Power Factor (Cos Phi)		0,88	0,88	0,88	0,88	0,89	0,89	0,89	0,89	0,89	0,89	0,89	0,90	0,90	
Power factor at maximum power⁽¹⁾ - 30XBP															
Standard unit															
Displacement Power Factor (Cos Phi)		0,88	0,88	0,88	0,88	0,89	0,89	0,89	0,89	0,89	0,89	0,89	0,90	0,90	
Unit + option 15LS															
Displacement Power Factor (Cos Phi)		0,88	0,88	0,88	0,88	0,89	0,89	0,89	0,89	0,89	0,89	0,89	0,90	0,90	
Nominal operating current draw⁽²⁾ - 30XB															
Standard unit	A	151	167	182	210	239	267	324	349	402	430	446	511	541	
Unit + option 15LS	A	141	157	172	197	226	254	306	330	383	411	427	492	519	
Nominal operating current draw⁽²⁾ - 30XBP															
Standard unit	A	145	161	176	202	231	259	313	337	390	418	434	499	527	
Unit + option 15LS	A	139	155	170	194	223	251	302	325	378	406	422	487	513	
Maximum operating current draw (Un)⁽¹⁾ - 30XB															
Standard unit	A	198	220	242	278	319	349	430	464	519	549	595	634	734	
Unit + option 15LS	A	188	210	232	265	306	336	412	445	500	530	576	615	711	
Maximum operating current draw (Un)⁽¹⁾ - 30XBP															
Standard unit	A	192	214	236	270	311	341	419	452	507	537	583	622	720	
Unit + option 15LS	A	186	208	230	262	303	333	408	440	495	525	571	610	706	
Maximum current (Un-10%)⁽¹⁾ - 30XB															
Standard unit	A	198	220	242	278	319	349	430	464	519	549	595	634	734	
Unit + option 15LS	A	188	210	232	265	306	336	412	445	500	530	576	615	711	
Maximum current (Un-10%)⁽¹⁾ - 30XBP															
Standard unit	A	192	214	236	270	311	341	419	452	507	537	583	622	720	
Unit + option 15LS	A	186	208	230	262	303	333	408	440	495	525	571	610	706	
Nominal start-up current⁽³⁾ - 30XB															
Standard unit	A	246	246	261	379	479	479	535	561	734	757	760	843	857	
Unit + option 15LS	A	245	245	262	378	480	480	536	562	735	759	761	845	865	
Unit + option 25C	A	213	224	224	346	442	442	492	492	676	691	691	733	756	
Nominal start-up current⁽³⁾ - 30XBP															
Standard unit	A	240	240	255	371	471	471	524	549	722	745	748	831	843	
Unit + option 15LS	A	234	234	249	363	463	463	513	537	710	733	736	819	829	
Unit + option 25C	A	207	218	218	338	434	434	481	480	664	679	679	721	742	
Maximum start-up current(Un)⁽²⁾ - 30XB															
Standard unit	A	274	274	292	407	510	510	583	616	782	812	812	902	951	
Unit + option 15LS	A	264	264	282	394	497	497	565	597	763	793	793	883	929	
Unit + option 25C	A	213	224	224	346	442	442	492	492	676	691	691	733	756	
Maximum start-up current(Un)⁽²⁾ - 30XBP															
Standard unit	A	268	268	286	399	502	502	572	604	770	800	800	890	937	
Unit + option 15LS	A	262	262	280	391	494	494	561	592	758	788	788	878	923	
Unit + option 25C	A	207	218	218	338	434	434	481	480	664	679	679	721	742	

(1) Values obtained at unit continuous maximum operating conditions (data given on the unit nameplate)

(2) Operating current of the smallest compressor(s) + fan current + locked rotor current or reduced start-up current of the largest compressor.

(3) Standardised EUROVENT conditions, water-cooled exchanger water inlet/outlet = 12°C/7°C, outdoor air temperature = 35°C.

ELECTRICAL DATA, 30XB-1100 TO 1700

30XB		1100	1200	1300	1400	1500	1550	1700
Power circuit supply								
Nominal voltage	V-ph-Hz	400-3-50						
Voltage range	V	360-440						
Control circuit supply		24 V via internal transformer						
Maximum operating input power⁽¹⁾ - 30XB								
Standard unit								
Circuit 1 ^(a)	kW	196	225	267	286	309	459	366
Circuit 2 ^(a)	kW	286	312	286	307	309	230	366
Option 081	kW	483	537	553	593	619	689	
Unit + option 15LS								
Circuit 1 ^(a)	kW	190	218	258	276	299	451	354
Circuit 2 ^(a)	kW	277	301	276	297	299	222	354
Option 081	kW	467	520	534	574	598	666	
Power factor at maximum power⁽¹⁾ - 30XB								
Standard unit								
Displacement Power Factor (Cos Phi)		0,88	0,88	0,88	0,88	0,88	0,89	0,89
Unit + option 15LS								
Displacement Power Factor (Cos Phi)		0,88	0,88	0,88	0,88	0,88	0,89	0,89
Nominal operating current draw⁽²⁾ - 30XB								
Standard unit								
Circuit 1 ^(a)	A	258	274	341	356	390	543	446
Circuit 2 ^(a)	A	358	392	356	386	390	273	446
Option 081	A	616	666	697	742	780	820	
Unit + option 15LS								
Circuit 1 ^(a)	A	247	263	325	340	372	530	427
Circuit 2 ^(a)	A	344	374	340	370	372	260	427
Option 081	A	590	637	665	710	745	782	
Maximum operating current draw (Un)⁽¹⁾ - 30XB								
Standard unit								
Circuit 1 ^(a)	A	320	366	440	470	509	740	593
Circuit 2 ^(a)	A	466	509	470	505	509	370	593
Option 081	A	788	877	912	977	1020	1113	
Unit + option 15LS								
Circuit 1 ^(a)	A	309	355	424	454	491	727	574
Circuit 2 ^(a)	A	452	491	454	489	491	357	574
Option 081	A	762	848	880	945	985	1074	
Maximum current (Un-10%)⁽¹⁾ - 30XB								
Standard unit								
Circuit 1 ^(a)	A	320	366	440	470	509	740	593
Circuit 2 ^(a)	A	466	509	470	505	509	370	593
Option 081	A	788	877	912	977	1020	1113	
Unit + option 15LS								
Circuit 1 ^(a)	A	309	355	424	454	491	727	574
Circuit 2 ^(a)	A	452	491	454	489	491	357	574
Option 081	A	762	848	880	945	985	1074	
Nominal start-up current⁽³⁾ - 30XB								
Standard unit								
Circuit 1 ^(a)	A	587	587	629	629	629	954	812
Circuit 2 ^(a)	A	629	629	629	629	629	477	812
Option 081	A	940	980	985	1015	1019	1316	
Option 081 & Opt 25c	A	802	820	844	862	862		
Unit + option 15LS								
Circuit 1 ^(a)	A	576	576	613	613	611	941	793
Circuit 2 ^(a)	A	615	611	613	613	611	464	793
Option 081	A	914	951	953	983	984	1290	
Option 081 & Opt 25c	A	776	791	812	830	826		

(1) Values obtained at unit continuous maximum operating conditions (data given on the unit nameplate)

(2) Operating current of the smallest compressor(s) + fan current + locked rotor current or reduced start-up current of the largest compressor.

(3) Standardised EUROVENT conditions, water-cooled exchanger water inlet/outlet = 12°C/7°C, outdoor air temperature = 35°C.

(a) When the machines are equipped with two power supplies, circuit 1 supplies the refrigerant circuit A and circuit 2 supplies the refrigerant circuit B or for units 30XB1550 to 1700 units: Circuit 1 supplies circuits A and B, circuit 2 supplies circuits C and D.

ELECTRICAL DATA, 30XB-1100 TO 1700

30XB		1100	1200	1300	1400	1500	1550	1700
Maximum start-up current(Un)⁽²⁾ - 30XB								
Standard unit								
Circuit 1 ^(a)	A	587	587	629	629	629	954	812
Circuit 2 ^(a)	A	629	629	629	629	629	477	812
Option 081	A	1046	1095	1095	1130	1134	1431	
Option 081 & Opt 25c		802	820	844	862	862		
Unit + option 15LS								
Circuit 1 ^(a)	A	576	576	613	613	611	941	793
Circuit 2 ^(a)	A	615	611	613	613	611	464	793
Option 081		1020	1066	1063	1098	1099	1393	
Option 081 & Opt 25c	A	776	791	812	830	826		

(2) Operating current of the smallest compressor(s) + fan current + locked rotor current or reduced start-up current of the largest compressor.

(a) When the machines are equipped with two power supplies, circuit 1 supplies the refrigerant circuit A and circuit 2 supplies the refrigerant circuit B or for units 30XB1550 to 1700 units: Circuit 1 supplies circuits A and B, circuit 2 supplies circuits C and D.

ELECTRICAL DATA, 30XBP-250 TO 1000

30XB 30XBP		250	300	350	400	450	500	600	700	750	800	850	900	1000
Power circuit supply														
Nominal voltage	V-ph-Hz	400-3-50												
Voltage range	V	360-440												
Control circuit supply		24 V via internal transformer												
Maximum operating input power⁽¹⁾ - 30XB														
Standard unit	kW	119	133	147	168	195	214	264	285	319	338	367	392	454
Unit + option 15LS	kW	112	126	140	159	185	204	251	271	305	324	353	378	437
Maximum operating input power⁽¹⁾ - 30XBP														
Standard unit	kW	117	131	145	165	192	211	259	279	314	333	362	386	447
Unit + option 15LS	kW	114	127	141	160	187	206	252	272	306	325	354	379	438
Power factor at maximum power⁽¹⁾ - 30XB														
Standard unit														
Displacement Power Factor (Cos Phi)		0,88	0,88	0,88	0,88	0,89	0,89	0,89	0,89	0,89	0,89	0,89	0,90	0,90
Unit + option 15LS														
Displacement Power Factor (Cos Phi)		0,88	0,88	0,88	0,88	0,89	0,89	0,89	0,89	0,89	0,89	0,89	0,90	0,90
Power factor at maximum power⁽¹⁾ - 30XBP														
Standard unit														
Displacement Power Factor (Cos Phi)		0,88	0,88	0,88	0,88	0,89	0,89	0,89	0,89	0,89	0,89	0,89	0,90	0,90
Unit + option 15LS														
Displacement Power Factor (Cos Phi)		0,88	0,88	0,88	0,88	0,89	0,89	0,89	0,89	0,89	0,89	0,89	0,90	0,90
Nominal operating current draw⁽²⁾ - 30XB														
Standard unit	A	151	167	182	210	239	267	324	349	402	430	446	511	541
Unit + option 15LS	A	141	157	172	197	226	254	306	330	383	411	427	492	519
Nominal operating current draw⁽²⁾ - 30XBP														
Standard unit	A	145	161	176	202	231	259	313	337	390	418	434	499	527
Unit + option 15LS	A	139	155	170	194	223	251	302	325	378	406	422	487	513
Maximum operating current draw (Un)⁽¹⁾ - 30XB														
Standard unit	A	198	220	242	278	319	349	430	464	519	549	595	634	734
Unit + option 15LS	A	188	210	232	265	306	336	412	445	500	530	576	615	711
Maximum operating current draw (Un)⁽¹⁾ - 30XBP														
Standard unit	A	192	214	236	270	311	341	419	452	507	537	583	622	720
Unit + option 15LS	A	186	208	230	262	303	333	408	440	495	525	571	610	706
Maximum current (Un-10%)⁽¹⁾ - 30XB														
Standard unit	A	198	220	242	278	319	349	430	464	519	549	595	634	734
Unit + option 15LS	A	188	210	232	265	306	336	412	445	500	530	576	615	711
Maximum current (Un-10%)⁽¹⁾ - 30XBP														
Standard unit	A	192	214	236	270	311	341	419	452	507	537	583	622	720
Unit + option 15LS	A	186	208	230	262	303	333	408	440	495	525	571	610	706
Nominal start-up current⁽³⁾ - 30XB														
Standard unit	A	246	246	261	379	479	479	535	561	734	757	760	843	857
Unit + option 15LS	A	245	245	262	378	480	480	536	562	735	759	761	845	865
Unit + option 25C	A	213	224	224	346	442	442	492	492	676	691	691	733	756
Nominal start-up current⁽³⁾ - 30XBP														
Standard unit	A	240	240	255	371	471	471	524	549	722	745	748	831	843
Unit + option 15LS	A	234	234	249	363	463	463	513	537	710	733	736	819	829
Unit + option 25C	A	207	218	218	338	434	434	481	480	664	679	679	721	742
Maximum start-up current(Un)⁽²⁾ - 30XB														
Standard unit	A	274	274	292	407	510	510	583	616	782	812	812	902	951
Unit + option 15LS	A	264	264	282	394	497	497	565	597	763	793	793	883	929
Unit + option 25C	A	213	224	224	346	442	442	492	492	676	691	691	733	756
Maximum start-up current(Un)⁽²⁾ - 30XBP														
Standard unit	A	268	268	286	399	502	502	572	604	770	800	800	890	937
Unit + option 15LS	A	262	262	280	391	494	494	561	592	758	788	788	878	923
Unit + option 25C	A	207	218	218	338	434	434	481	480	664	679	679	721	742

(1) Values obtained at unit continuous maximum operating conditions (data given on the unit nameplate)

(2) Operating current of the smallest compressor(s) + fan current + locked rotor current or reduced start-up current of the largest compressor.

(3) Standardised EUROVENT conditions, water-cooled exchanger water inlet/outlet = 12°C/7°C, outdoor air temperature = 35°C.

ELECTRICAL DATA, 30XBP-1100 TO 1500

30XBP		1100	1200	1300	1400	1500
Power circuit supply						
Nominal voltage	V-ph-Hz	400-3-50				
Voltage range	V	360-440				
Control circuit supply		24 V via internal transformer				
Maximum operating input power⁽¹⁾ - 30XBP						
Standard unit						
Circuit 1 ^(a)	kW	154	164	201	211	230
Circuit 2 ^(a)	kW	214	234	210	229	230
Option 081	kW	368	397	411	439	460
Unit + option 15LS						
Circuit 1 ^(a)	kW	145	157	193	200	219
Circuit 2 ^(a)	kW	200	220	199	215	216
Option 081	kW	348	380	397	419	439
Power factor at maximum power⁽¹⁾ - 30XBP						
Standard unit						
Displacement Power Factor (Cos Phi)		0,88	0,88	0,88	0,88	0,88
Unit + option 15LS						
Displacement Power Factor (Cos Phi)		0,86	0,87	0,87	0,86	0,86
Nominal operating current draw⁽²⁾ - 30XBP						
Standard unit						
Circuit 1 ^(a)	A	251	267	331	346	379
Circuit 2 ^(a)	A	349	381	346	376	379
Option 081	A	600	648	677	722	758
Unit + option 15LS						
Circuit 1 ^(a)	A	244	260	321	336	368
Circuit 2 ^(a)	A	335	363	330	360	361
Option 081	A	584	630	657	702	736
Maximum operating current draw (Un)⁽¹⁾ - 30XBP						
Standard unit						
Circuit 1 ^(a)	A	313	359	430	460	498
Circuit 2 ^(a)	A	457	498	460	495	498
Option 081	A	772	859	892	957	998
Unit + option 15LS						
Circuit 1 ^(a)	A	306	352	420	450	487
Circuit 2 ^(a)	A	448	487	450	485	487
Option 081	A	584	630	657	702	736
Maximum current (Un-10%)⁽¹⁾ - 30XBP						
Standard unit						
Circuit 1 ^(a)	A	313	359	430	460	498
Circuit 2 ^(a)	A	457	498	460	495	498
Option 081	A	772	859	892	957	998
Unit + option 15LS						
Circuit 1 ^(a)	A	306	352	420	450	487
Circuit 2 ^(a)	A	448	487	450	485	487
Option 081	A	584	630	657	702	736
Nominal start-up current⁽³⁾ - 30XBP						
Standard unit						
Circuit 1 ^(a)	A	580	580	619	619	618
Circuit 2 ^(a)	A	620	618	619	619	618
Option 081	A	923	962	965	995	997
Option 081 & Opt 25c	A	786	801,5	824	841,5	839,5
Unit + option 15LS						
Circuit 1 ^(a)	A	573	573	609	609	607
Circuit 2 ^(a)	A	611	607	609	609	607
Option 081	A	907	944	945	975	975
Option 081 & Opt 25c	A	770	783,5	804	821,5	817,5

(1) Values obtained at unit continuous maximum operating conditions (data given on the unit nameplate)

(2) Operating current of the smallest compressor(s) + fan current + locked rotor current or reduced start-up current of the largest compressor.

(3) Standardised EUROVENT conditions, water-cooled exchanger water inlet/outlet = 12°C/7°C, outdoor air temperature = 35°C.

(a) When the machines are equipped with two power supplies, circuit 1 supplies the refrigerant circuit A and circuit 2 supplies the refrigerant circuit B or for units 30XBP1550 to 1700 units: Circuit 1 supplies circuits A and B, circuit 2 supplies circuits C and D.

ELECTRICAL DATA, 30XBP-1100 TO 1500

30XBP		1100	1200	1300	1400	1500
Maximum start-up current(Un)⁽²⁾ - 30XBP						
Standard unit						
Circuit 1 ^(a)	A	580	580	619	619	618
Circuit 2 ^(a)	A	620	618	619	619	618
Option 081	A	1030	1077	1075	1110	1112
Option 081 & Opt 25c	A	786	801,5	824	841,5	839,5
Unit + option 15LS						
Circuit 1 ^(a)	A	573	573	609	609	607
Circuit 2 ^(a)	A	611	607	609	609	607
Option 081	A	1014	1059	1055	1090	1090
Option 081 & Opt 25c	A	770	783,5	804	821,5	817,5

(2) Operating current of the smallest compressor(s) + fan current + locked rotor current or reduced start-up current of the largest compressor.

(a) When the machines are equipped with two power supplies, circuit 1 supplies the refrigerant circuit A and circuit 2 supplies the refrigerant circuit B or for units 30XBP1550 to 1700 units: Circuit 1 supplies circuits A and B, circuit 2 supplies circuits C and D.

ELECTRICAL DATA, 30XB WITH OPTION CU/AL HEAT EXCHANGER

30XB with option 254 or 255		250	300	350	400	450	500	600	700	750	800	850	900	1000
Power circuit supply														
Nominal voltage	V-ph-Hz	400-3-50												
Voltage range	V	360-440												
Control circuit supply														
24 V via internal transformer														
Maximum operating input power⁽¹⁾ - 30XB														
Standard unit	kW	119	133	149	168	195	216	264	285	321	340	371	398	460
Unit + option 15LS	kW	112	126	141	159	185	205	251	271	306	325	355	381	438
Power factor at maximum power⁽¹⁾ - 30XB														
Standard unit														
Displacement Power Factor (Cos Phi)		0,88	0,88	0,88	0,88	0,89	0,89	0,89	0,89	0,89	0,89	0,89	0,90	0,90
Unit + option 15LS														
Displacement Power Factor (Cos Phi)		0,88	0,88	0,88	0,88	0,89	0,89	0,89	0,89	0,89	0,89	0,89	0,90	0,90
Nominal operating current draw⁽²⁾ - 30XB														
Standard unit	A	151	167	185	210	239	270	324	349	405	433	452	520	550
Unit + option 15LS	A	141	157	174	197	226	256	306	330	385	413	431	498	525
Maximum operating current draw (Un)⁽¹⁾ - 30XB														
Standard unit	A	198	220	245	278	319	352	430	464	522	552	601	643	743
Unit + option 15LS	A	188	210	234	265	306	338	412	445	502	532	580	621	717
Maximum current (Un-10%)⁽¹⁾ - 30XB														
Standard unit	A	198	220	245	278	319	352	430	464	522	552	601	643	743
Unit + option 15LS	A	188	210	234	265	306	338	412	445	502	532	580	621	717
Nominal start-up current⁽³⁾ - 30XB														
Standard unit	A	246	246	264	379	479	482	535	561	737	760	766	852	866
Unit + option 15LS	A	245	245	263	378	480	481	536	562	738	761	765	851	871
Unit + option 25C	A	213	224	224	346	442	442	492	492	676	691	691	733	756
Maximum start-up current(Un)⁽²⁾ - 30XB														
Standard unit	A	274	274	295	407	510	513	583	616	785	815	818	911	960
Unit + option 15LS	A	264	264	284	394	497	499	565	597	765	795	797	889	935
Unit + option 25C	A	213	224	224	346	442	442	492	492	676	691	691	733	756

(1) Values obtained at unit continuous maximum operating conditions (data given on the unit nameplate)

(2) Operating current of the smallest compressor(s) + fan current + locked rotor current or reduced start-up current of the largest compressor.

(3) Standardised EUROVENT conditions, water-cooled exchanger water inlet/outlet = 12°C/7°C, outdoor air temperature = 35°C.

ELECTRICAL DATA, 30XB WITH OPTION CU/AL HEAT EXCHANGER

30XB with option 254 or 255		1100	1200	1300	1400	1500	1550	1700
Power circuit supply								
Nominal voltage	V-ph-Hz	400-3-50						
Voltage range	V	360-440						
Control circuit supply								
24 V via internal transformer								
Maximum operating input power⁽¹⁾ - 30XB								
Standard unit								
Circuit 1 ^(a)	kW	200	225	267	286	309	459	366
Circuit 2 ^(a)	kW	294	312	286	307	309	230	366
Option 081	kW	488	537	553	593	619	689	
Unit + option 15LS								
Circuit 1 ^(a)	kW	190	220	258	276	299	451	354
Circuit 2 ^(a)	kW	277	303	276	297	299	222	354
Option 081	kW	467	524	534	574	598	666	
Power factor at maximum power⁽¹⁾ - 30XB								
Standard unit								
Displacement Power Factor (Cos Phi)		0,88	0,88	0,88	0,88	0,88	0,89	0,89
Unit + option 15LS								
Displacement Power Factor (Cos Phi)		0,88	0,88	0,88	0,88	0,88	0,89	0,89
Nominal operating current draw⁽²⁾ - 30XB								
Standard unit								
Circuit 1 ^(a)	A	261	274	341	356	390	543	446
Circuit 2 ^(a)	A	364	392	356	386	390	273	446
Option 081	A	625	666	697	742	780	820	
Unit + option 15LS								
Circuit 1 ^(a)	A	247	265	325	340	372	530	427
Circuit 2 ^(a)	A	344	376	340	370	372	260	427
Option 081	A	590	641	665	710	745	782	
Maximum operating current draw (Un)⁽¹⁾ - 30XB								
Standard unit								
Circuit 1 ^(a)	A	323	366	440	470	509	740	593
Circuit 2 ^(a)	A	472	509	470	505	509	370	593
Option 081	A	787	877	912	977	1020	1113	
Unit + option 15LS								
Circuit 1 ^(a)	A	309	357	424	454	491	727	574
Circuit 2 ^(a)	A	452	493	454	489	491	357	574
Option 081	A	762	852	880	945	985	1074	
Maximum current (Un-10%)⁽¹⁾ - 30XB								
Standard unit								
Circuit 1 ^(a)	A	319	366	440	470	509	740	593
Circuit 2 ^(a)	A	464	509	470	505	509	370	593
Option 081	A	785	877	912	977	1020	1113	
Unit + option 15LS								
Circuit 1 ^(a)	A	309	357	424	454	491	727	574
Circuit 2 ^(a)	A	452	493	454	489	491	357	574
Option 081	A	762	850	880	945	985	1074	
Nominal start-up current⁽³⁾ - 30XB								
Standard unit								
Circuit 1 ^(a)	A	590	587	629	629	629	954	812
Circuit 2 ^(a)	A	635	629	629	629	629	477	812
Option 081	A	949	986	985	1015	1019	1316	
Option 081 & Opt 25c	A	811	820	844	862	862		
Unit + option 15LS								
Circuit 1 ^(a)	A	576	578	613	613	611	941	793
Circuit 2 ^(a)	A	615	613	613	613	611	464	793
Option 081	A	1020	1070	1063	1098	1099	1393	
Option 081 & Opt 25c	A	776	795	812	830	826		

(1) Values obtained at unit continuous maximum operating conditions (data given on the unit nameplate)

(2) Operating current of the smallest compressor(s) + fan current + locked rotor current or reduced start-up current of the largest compressor.

(3) Standardised EUROVENT conditions, water-cooled exchanger water inlet/outlet = 12°C/7°C, outdoor air temperature = 35°C.

(a) When the machines are equipped with two power supplies, circuit 1 supplies the refrigerant circuit A and circuit 2 supplies the refrigerant circuit B or for units 30XB1550 to 1700 units: Circuit 1 supplies circuits A and B, circuit 2 supplies circuits C and D.

ELECTRICAL DATA, 30XB WITH OPTION CU/AL HEAT EXCHANGER

30XB with option 254 or 255		1100	1200	1300	1400	1500	1550	1700
Maximum start-up current(Un)⁽²⁾ - 30XB								
Standard unit								
Circuit 1 ^(a)	A	590	590	629	629	629	954	812
Circuit 2 ^(a)	A	635	632	629	629	629	477	812
Option 081	A	1055	1101	1095	1130	1134	1431	
Option 081 & Opt 25c	A	811	820	844	862	862		
Unit + option 15LS								
Circuit 1 ^(a)	A	576	578	613	613	611	941	793
Circuit 2 ^(a)	A	615	613	613	613	611	464	793
Option 081	A	1020	1070	1063	1098	1099	1393	
Option 081 & Opt 25c	A	776	795	812	830	826		

(2) Operating current of the smallest compressor(s) + fan current + locked rotor current or reduced start-up current of the largest compressor.

(a) When the machines are equipped with two power supplies, circuit 1 supplies the refrigerant circuit A and circuit 2 supplies the refrigerant circuit B or for units 30XB1550 to 1700 units: Circuit 1 supplies circuits A and B, circuit 2 supplies circuits C and D.

ELECTRICAL DATA

Electrical data notes and operating conditions for 30XB units:	
<ul style="list-style-type: none"> 30XB&XBP 250 to 1000 units have a single power connection point; 30XB & XBP 1100 to 1700 units have two connection points. The control box includes the following standard features: <ul style="list-style-type: none"> One general disconnect switch per circuit Starter and motor protection devices for each compressor, the fan(s) and the pump Control devices <p>Field connections:</p> <ul style="list-style-type: none"> All connections to the system and the electrical installations must be in full accordance with all applicable local codes. The Carrier 30XB & 30XBP units are designed and built to ensure conformance with these codes. The recommendations of European standard EN 60204-1 (corresponds to IEC 60204-1) (machine safety - electrical machine components - part 1: General regulations) are specifically taken into account, when designing the electrical equipment. <p>IMPORTANT:</p> <ul style="list-style-type: none"> Generally the recommendations of IEC 60364 are accepted as compliance with the requirements of the installation regulations. Conformance with EN 60204 is the best means of ensuring compliance with the Machines Directive ~ 1.5.1. Annex B of EN 60204-1 describes the electrical characteristics used for the operation of the machines. <ol style="list-style-type: none"> Environment* . Environment as classified in EN 60364 (corresponds to IEC 60364): <ul style="list-style-type: none"> Outdoor installation* Ambient temperature range: from -20°C to +55°C** Altitude less than or equal to 2000 m (for hydraulic module, see paragraph 4.7 in the IOM) Presence of hard solids, class AE3 (no significant dust present)* Presence of corrosive and polluting substances, class AF1 (negligible) Competence of persons: BA4 (Persons wise); 30XB & 30XBP machines are not intended to be installed in locations open to anyone, including people with disabilities and children. Compatibility for low-frequency conducted disturbances according to IEC61000-2-2 and to class 2 levels per IEC61000-2-4 standard: <ul style="list-style-type: none"> Power supply frequency variation : +-2Hz Phase imbalance : 2% Total Voltage Harmonic Distortion (THDV) : 8%** The neutral (N) line must not be connected directly to the unit (if necessary use a transformer). Overcurrent protection of the power supply conductors is not provided with the unit. 	<ol style="list-style-type: none"> The factory installed disconnect switch(es)/circuit breaker(s) is (are) of a type suitable for power interruption in accordance with EN 60947-3 (corresponds to IEC 60947-3). The units are designed for simplified connection on TN(s) networks (IEC 60364). For IT networks provide a local earth and consult competent local organisations to complete the electrical installation. Units delivered with variable frequency drive(s) (options : 28, 17) are not compatible with IT network. 30XB units are designed to use for domestic / residential and industrial environments: <ul style="list-style-type: none"> Machines that are not equipped with variable frequency drive(s) are in accordance with the codes : <ul style="list-style-type: none"> 61000-6-3: General standards - Standard emission for residential, commercial and light industry. 61000-6-2: General standards - Immunity for industrial environments. Machines that are equipped with variable frequency drive(s) (options : 28, 17) are in accordance with standard EN61800 - 3 electric power variable speed drives - art 3: EMC requirements and specific test methods for the following classifications:- <ul style="list-style-type: none"> Use in the first and second environments***. Category C2 applicable in the first environment, on stationary devices designed to be installed and commissioned by a professional. <p>Warning: In a residential environment, this product may cause radio interference in which case additional mitigation measures could be required.</p> <ul style="list-style-type: none"> Leakage currents: If protection by monitoring the leakage currents is necessary to ensure the safety of the installation, the presence of additional leakage currents introduced by the use of variable frequency drive(s) in the unit must be considered. In particular these protection devices shall be of reinforced immunity types and have a threshold not lower than 150 mA. Capacitors that are integrated as part of the option 231 can generate electrical disturbances in the installation the unit is connected to. Presence of these capacitors must be considered during the electrical study prior to the start-up. <p>NOTE: If particular aspects of an actual installation do not conform to the conditions described above, or if there are other conditions which should be considered, always contact your local Carrier representative.</p> <p>* The required protection level for this class is IP43BW (according to reference document IEC 60529). All 30XB & XBP units are protected to IP44CW and fulfil this protection condition.</p> <p>** The maximum ambient temperature allowed for machines equipped with option 231 is +40°C</p>

PART LOAD PERFORMANCE

ESEER (in accordance with EUROVENT)

The ESEER (European seasonal energy efficiency ratio) permits evaluation of the average energy efficiency at part load, based on four operating conditions defined by Eurovent. The ESEER is the average value of energy efficiency ratios (EER) at different operating conditions, weighted by the operating time.

ESEER (European seasonal energy efficiency ratio)

Load %	Air temperature °C	Energy efficiency	Operating time %
100	35	EER ₁	3
75	30	EER ₂	33
50	25	EER ₃	41
25	20	EER ₄	23

$$ESEER = EER_1 \times 3\% + EER_2 \times 33\% + EER_3 \times 41\% + EER_4 \times 23\%$$

NOTE: Constant leaving water temperature 7°C.

SEER for comfort chillers (in accordance with EU ECODESIGN)

The SEER (Seasonal energy efficiency ratio) permits the evaluation of the average energy efficiency of comfort chillers, based on multiple operating conditions (load variation from 0% to 100%). From 1st January 2018, Tier 1 and from 1st January 2021, Tier 2, European member states will impose minimum SEER values to meet the requirements of Eco-design directive for ENER Lot 21 comfort cooling chillers. The Ecodesign Directive aims to minimize the environmental impact of energy-related products through consideration of their full lifecycle.



SEER is the new metric for chillers in **comfort cooling applications**.

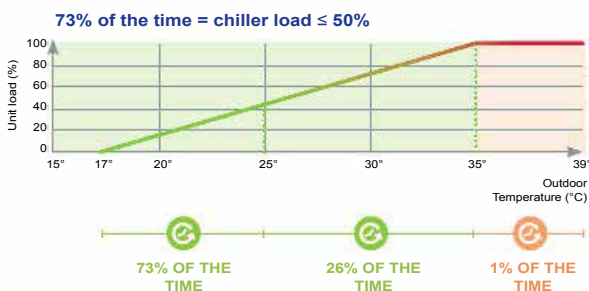

EU ECODESIGN MEPS(*) for air-cooled chillers		Tier 1 (from 01/01/2018)	Tier 2 (from 01/01/2021)
SEER for comfort Chillers < 400kW	kWh/kWh	3,80	4,10
SEER for comfort Chillers > 400kW	kWh/kWh	4,10	4,55

(*) Minimum Efficiency Performance Standards set by EU member states to comply with EU Ecodesign directive.

SEPR for process chillers (in accordance with EU ECODESIGN)

The SEPR (Seasonal energy performance ratio) permits the evaluation of the average energy efficiency of process chillers, based on multiple operating conditions (load variation from 80% to 100%). From 1st January 2018, Tier 1 and from 1st January 2021, Tier 2, European member states will impose minimum SEPR values for process chillers to meet the requirements of Eco-design directive for ENER Lot 21 for high temperature process chillers (7°C to 12°C) and for ENTR Lot 1 for low temperature process chillers (-25°C to -8°C) and medium temperature process chillers (-8°C to 7°C). The Ecodesign Directive aims to minimize the environmental impact of energy-related products through consideration of their full lifecycle. All process chillers marked with a CE label must meet the required SEPR (Seasonal Energy Performance Ratio) value stipulated in EU Directive.



SEPR is the new metric for chillers in **industrial process cooling applications**.

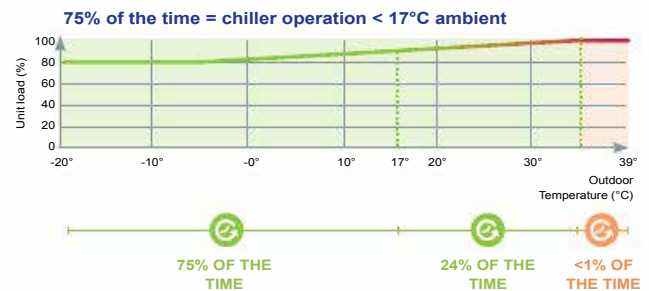

EU ECODESIGN MEPS(*) for air-cooled chillers		Tier 1 (from 01/01/2018)	Tier 2 (from 01/01/2021)
SEPR for medium temperature Process Chillers < 300 kW	kWh/kWh	2,24	2,58
SEPR for medium temperature Process Chillers > 300 kW	kWh/kWh	2,80	3,22

EU ECODESIGN MEPS(*) for air-cooled chillers		Tier 1 (from 01/07/2016)	Tier 2 (from 01/07/2018)
SEPR for high temperature Process Chillers < 400 kW	kWh/kWh	4,50	5,00
SEPR for high temperature Process Chillers > 400 kW	kWh/kWh	5,00	5,50

(*) Minimum Efficiency Performance Standards set by EU member states to comply with EU Ecodesign directive.

SOUND SPECTRUM 30XB UNITS

30XB - Standard unit

		Octave bands, Hz ⁽¹⁾						Sound power level ⁽²⁾	
		125	250	500	1k	2k	4k		
250	dB	96	95	92	98	86	81	dB(A)	99
300	dB	96	95	92	98	86	81	dB(A)	99
350	dB	97	95	92	98	86	81	dB(A)	99
400	dB	97	96	94	98	88	83	dB(A)	99
450	dB	104	106	95	96	88	84	dB(A)	101
500	dB	96	95	95	96	91	86	dB(A)	99
600	dB	103	105	96	95	90	86	dB(A)	101
700	dB	97	95	95	96	91	86	dB(A)	99
750	dB	104	107	97	99	90	86	dB(A)	103
800	dB	100	101	98	100	92	88	dB(A)	103
850	dB	99	98	97	97	91	88	dB(A)	101
900	dB	100	103	98	102	91	87	dB(A)	104
1000	dB	101	101	98	99	90	90	dB(A)	102
1100	dB	101	103	100	99	94	88	dB(A)	103
1200	dB	101	103	99	98	94	88	dB(A)	102
1300	dB	102	103	102	101	94	88	dB(A)	104
1400	dB	101	103	102	101	94	88	dB(A)	104
1500	dB	101	103	102	101	94	88	dB(A)	104
1550	dB	103	103	100	102	92	91	dB(A)	104
1700	dB	102	101	100	100	94	91	dB(A)	104

- (1) In dB ref=10⁻¹² W, as a guideline. Measured in accordance with ISO 9614-1.
 (2) In dB ref=10⁻¹² W, weighting (A), with uncertainty +/-3 dB. Measured in accordance with ISO 9614-1 and certified by Eurovent.

30XB - Unit with Option 15LS

		Octave bands, Hz ⁽¹⁾						Sound power level ⁽²⁾	
		125	250	500	1k	2k	4k		
250	dB	88	89	83	84	76	68	dB(A)	87
300	dB	88	89	83	84	76	68	dB(A)	87
350	dB	88	89	83	84	76	68	dB(A)	87
400	dB	89	92	87	86	80	71	dB(A)	90
450	dB	90	96	87	86	80	69	dB(A)	91
500	dB	92	94	89	87	81	72	dB(A)	91
600	dB	90	96	91	88	81	77	dB(A)	93
700	dB	92	94	90	87	82	73	dB(A)	92
750	dB	91	97	91	89	80	70	dB(A)	94
800	dB	92	94	92	90	81	72	dB(A)	94
850	dB	96	96	92	89	81	74	dB(A)	94
900	dB	93	94	94	92	80	71	dB(A)	95
1000	dB	97	96	93	89	79	75	dB(A)	94
1100	dB	97	95	91	88	86	85	dB(A)	94
1200	dB	97	95	91	88	86	85	dB(A)	94
1300	dB	97	98	99	93	90	87	dB(A)	99
1400	dB	97	95	92	90	88	86	dB(A)	95
1500	dB	98	96	93	91	89	87	dB(A)	96
1550	dB	100	97	95	91	81	77	dB(A)	96
1700	dB	98	98	94	91	83	76	dB(A)	96

- (1) In dB ref=10⁻¹² W, as a guideline. Measured in accordance with ISO 9614-1.
 (2) In dB ref=10⁻¹² W, weighting (A), with uncertainty +/-3 dB. Measured in accordance with ISO 9614-1 and certified by Eurovent.

30XB - Unit with Option 15

		Octave bands, Hz ⁽¹⁾						Sound power level ⁽²⁾	
		125	250	500	1k	2k	4k		
250	dB	95	94	90	90	83	78	dB(A)	93
300	dB	95	94	90	90	83	78	dB(A)	93
350	dB	95	94	91	90	83	78	dB(A)	94
400	dB	96	95	92	91	85	80	dB(A)	95
450	dB	96	94	92	91	86	80	dB(A)	95
500	dB	96	94	93	91	86	81	dB(A)	95
600	dB	96	97	94	93	89	82	dB(A)	97
700	dB	97	95	94	92	86	81	dB(A)	96
750	dB	101	99	94	94	86	81	dB(A)	97
800	dB	98	96	95	95	87	82	dB(A)	98
850	dB	99	96	95	94	87	83	dB(A)	97
900	dB	99	97	95	96	87	82	dB(A)	99
1000	dB	99	96	95	94	87	83	dB(A)	98
1100	dB	101	98	95	91	90	87	dB(A)	98
1200	dB	101	98	95	91	90	87	dB(A)	98
1300	dB	102	99	99	95	92	88	dB(A)	100
1400	dB	101	99	96	93	90	87	dB(A)	99
1500	dB	101	99	96	93	90	87	dB(A)	99
1550	dB	101	98	97	97	89	85	dB(A)	100
1700	dB	102	99	98	97	90	86	dB(A)	100

- (1) In dB ref=10⁻¹² W, as a guideline. Measured in accordance with ISO 9614-1.
 (2) In dB ref=10⁻¹² W, weighting (A), with uncertainty +/-3 dB. Measured in accordance with ISO 9614-1 and certified by Eurovent.

30XB - Unit with Option 15LS+

		Octave bands, Hz ⁽¹⁾						Sound power level ⁽²⁾	
		125	250	500	1k	2k	4k		
450	dB	89	93	84	85	76	67	dB(A)	89
500	dB	90	92	85	85	77	70	dB(A)	89
600	dB	91	93	88	87	79	77	dB(A)	91
700	dB	92	92	87	85	79	73	dB(A)	90
750	dB	92	94	89	87	79	73	dB(A)	91
800	dB	93	92	90	88	80	75	dB(A)	92
850	dB	93	92	90	87	79	74	dB(A)	91
900	dB	94	92	91	89	80	76	dB(A)	93
1000	dB	94	91	91	87	79	75	dB(A)	92
1100	dB	97	93	90	87	85	84	dB(A)	93
1200	dB	97	93	90	87	85	84	dB(A)	93
1300	dB	95	96	97	91	88	85	dB(A)	97
1400	dB	97	95	91	88	86	85	dB(A)	94
1500	dB	98	96	92	89	87	86	dB(A)	95
1550	dB	95	93	93	89	80	76	dB(A)	93
1700	dB	95	94	92	89	81	76	dB(A)	93

- (1) In dB ref=10⁻¹² W, as a guideline. Measured in accordance with ISO 9614-1.
 (2) In dB ref=10⁻¹² W, weighting (A), with uncertainty +/-3 dB. Measured in accordance with ISO 9614-1 and certified by Eurovent.

SOUND SPECTRUM 30XBP UNITS

30XBP - Standard unit

		Octave bands, Hz ⁽¹⁾						Sound power level ⁽²⁾	
		125	250	500	1k	2k	4k		
250	dB	96	95	92	98	86	81	dB(A)	99
300	dB	96	95	92	98	86	81	dB(A)	99
350	dB	97	95	92	98	86	81	dB(A)	99
400	dB	97	96	94	98	88	83	dB(A)	99
450	dB	104	106	95	96	88	84	dB(A)	101
500	dB	96	95	95	96	91	86	dB(A)	99
600	dB	103	105	96	95	90	86	dB(A)	101
700	dB	97	95	95	96	91	86	dB(A)	99
750	dB	104	107	97	99	90	86	dB(A)	103
800	dB	100	101	98	100	92	88	dB(A)	103
850	dB	99	98	97	97	91	88	dB(A)	101
900	dB	100	103	98	102	91	87	dB(A)	104
1000	dB	101	101	98	99	90	90	dB(A)	102
1100	dB	101	103	100	99	94	88	dB(A)	103
1200	dB	101	103	99	98	94	88	dB(A)	102
1300	dB	102	103	102	101	94	88	dB(A)	104
1400	dB	101	103	102	101	94	88	dB(A)	104
1500	dB	101	103	102	101	94	88	dB(A)	104

- (1) In dB ref=10⁻¹² W, as a guideline. Measured in accordance with ISO 9614-1.
 (2) In dB ref=10⁻¹² W, weighting (A), with uncertainty +/-3 dB. Measured in accordance with ISO 9614-1 and certified by Eurovent.

30XBP - Unit with Option 15LS

		Octave bands, Hz ⁽¹⁾						Sound power level ⁽²⁾	
		125	250	500	1k	2k	4k		
250	dB	88	89	83	84	76	68	dB(A)	87
300	dB	88	89	83	84	76	68	dB(A)	87
350	dB	88	89	83	84	76	68	dB(A)	87
400	dB	89	92	87	86	80	71	dB(A)	90
450	dB	90	96	87	86	80	69	dB(A)	91
500	dB	92	94	89	87	81	72	dB(A)	91
600	dB	90	96	91	88	81	77	dB(A)	93
700	dB	92	94	90	87	82	73	dB(A)	92
750	dB	91	97	91	89	80	70	dB(A)	94
800	dB	92	94	92	90	81	72	dB(A)	94
850	dB	96	96	92	89	81	74	dB(A)	94
900	dB	93	94	94	92	80	71	dB(A)	95
1000	dB	97	96	93	89	79	75	dB(A)	94
1100	dB	97	95	91	88	86	85	dB(A)	94
1200	dB	97	95	91	88	86	85	dB(A)	94
1300	dB	97	98	99	93	90	87	dB(A)	99
1400	dB	97	95	92	90	88	86	dB(A)	95
1700	dB	98	96	93	91	89	87	dB(A)	96

- (1) In dB ref=10⁻¹² W, as a guideline. Measured in accordance with ISO 9614-1.
 (2) In dB ref=10⁻¹² W, weighting (A), with uncertainty +/-3 dB. Measured in accordance with ISO 9614-1 and certified by Eurovent.

30XBP - Unit with Option 15

		Octave bands, Hz ⁽¹⁾						Sound power level ⁽²⁾	
		125	250	500	1k	2k	4k		
250	dB	95	94	90	90	83	78	dB(A)	93
300	dB	95	94	90	90	83	78	dB(A)	93
350	dB	95	94	91	90	83	78	dB(A)	94
400	dB	96	95	92	91	85	80	dB(A)	95
450	dB	96	94	92	91	86	80	dB(A)	95
500	dB	96	94	93	91	86	81	dB(A)	95
600	dB	96	97	94	93	89	82	dB(A)	97
700	dB	97	95	94	92	86	81	dB(A)	96
750	dB	101	99	94	94	86	81	dB(A)	97
800	dB	98	96	95	95	87	82	dB(A)	98
850	dB	99	96	95	94	87	83	dB(A)	97
900	dB	99	97	95	96	87	82	dB(A)	99
1000	dB	99	96	95	94	87	83	dB(A)	98
1300	dB	101	98	95	91	90	87	dB(A)	98
1400	dB	101	98	95	91	90	87	dB(A)	98
1500	dB	102	99	99	95	92	88	dB(A)	100
1550	dB	101	99	96	93	90	87	dB(A)	99
1700	dB	101	99	96	93	90	87	dB(A)	99

- (1) In dB ref=10⁻¹² W, as a guideline. Measured in accordance with ISO 9614-1.
 (2) In dB ref=10⁻¹² W, weighting (A), with uncertainty +/-3 dB. Measured in accordance with ISO 9614-1 and certified by Eurovent.

OPERATING LIMITS

Water heat exchanger	Minimum	Maximum
Entering temperature at start-up °C	-	45 ⁽¹⁾
Leaving temperature during operation °C	3,3	15
Entering/leaving water temperature difference K	2,8	10
Condenser air temperature	Minimum	Maximum
Storage	-20	68
Operation, standard unit	-10	55 ⁽²⁾
With winter operation option (option 28)	-20	55 ⁽²⁾
With Low noise option (option 15LS)	-10	55 ⁽²⁾

Note: If the air temperature is below 0°C, a glycol/water solution or the frost protection option must be used.

Note: If the leaving water temperature is below 4°C, a glycol/water solution or the frost protection option must be used.

(1) Based on the installation type and the air temperature

(2) Part load, depended of sizes & leaving water temperature

Units without hydraulic module

30XB & 30XBP	Minimum flow rate ⁽¹⁾ (l/s)	Maximum flow rate ⁽²⁾ (l/s)
250	3,6	37,5
300	4,0	40,5
350	4,3	40,5
400	5,3	34,1
450	6,0	36,9
500	6,7	42,0
600	8,1	45,0
700	8,9	56,1
750	9,6	59,1
800	10,4	67,1
850	11,0	67,1
900	11,8	73,9
1000	13,1	83,9
1100	15,1	87,8
1200	16,4	126,5
1300	17,5	92,9
1400	16,4	132,1
1500	18,8	107,4
1550	19,9	109,4
1700	22,0	107,4

(1) Minimum flow rate for maximum allowable water temperature difference conditions (10K) under Eurovent conditions

(2) Maximum flow rate for a pressure drop of 100 kPa in the exchanger

OPERATING RANGE

30XB/XBP units with options 15LS or 15LS+

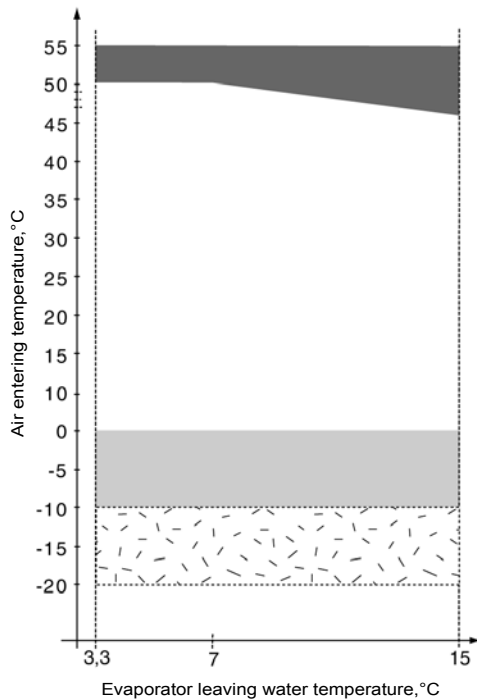

30XB / XBP Standard units

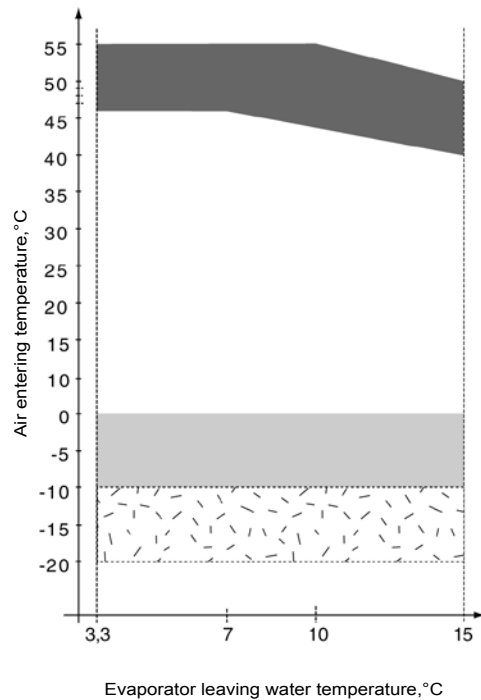

Legend

Operating range, unit equipped with option 28 (winter operation)

Below 0°C air temperature the unit must either be equipped with the evaporator frost protection option (41A or 41B), or the water loop must be protected against frost by using a frost protection solution (by the installer).

Part load average

DIMENSIONS / CLEARANCES

30XB250 to 350, 30XBP250 to 350
 30XB250 to 300 with option 254/255

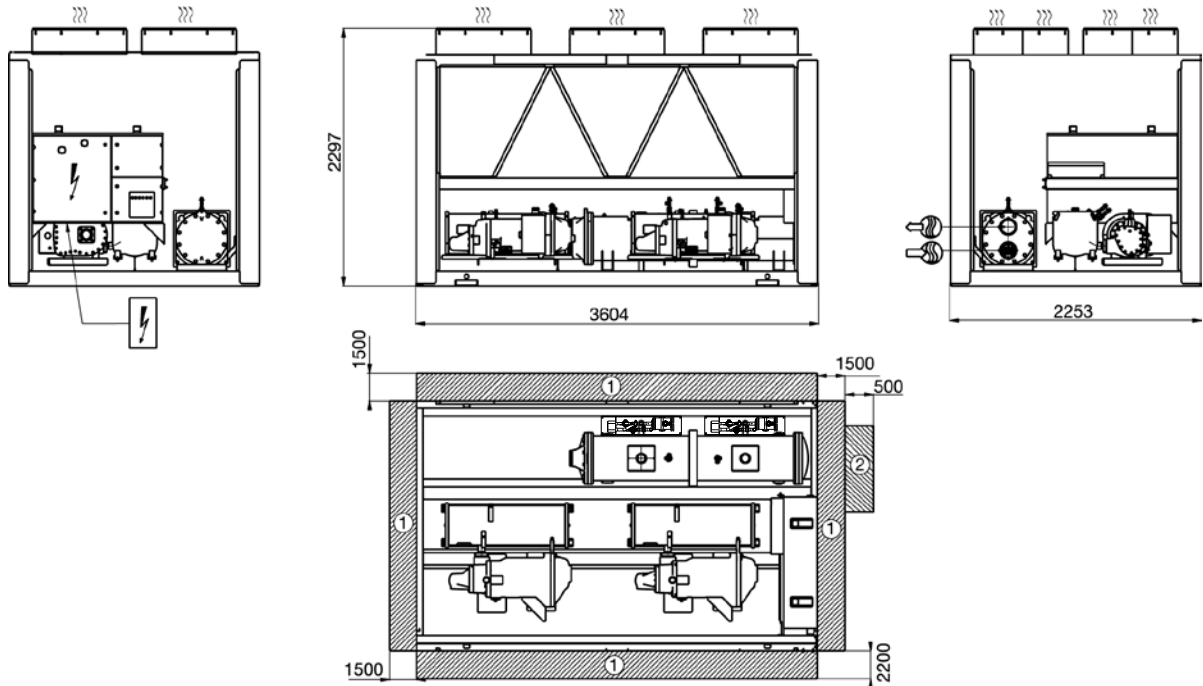

30XB400 to 450, 30XBP400 to 500
 30XB350 to 400 with option 254/255

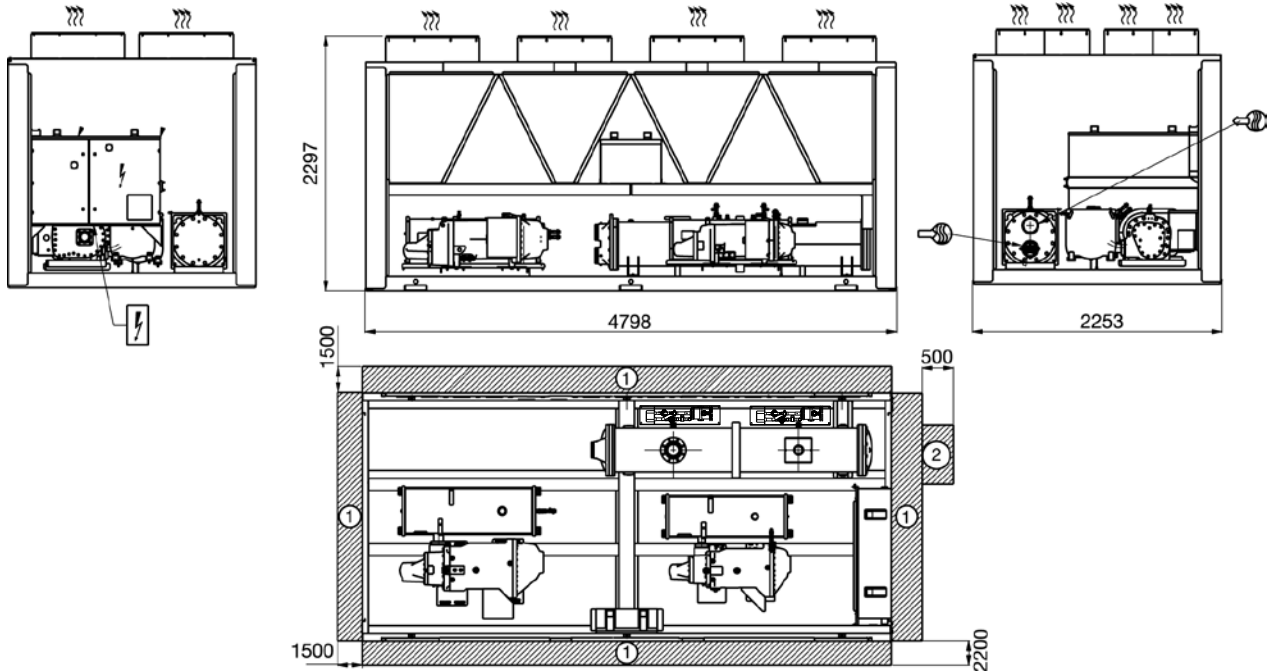

Legend

All dimensions are given in mm.

- ① Required clearances for maintenance (see note)
- ② Recommended space for evaporator tube removal
- Water inlet for standard unit - for options 5, 6, 100A, 100C, 107 refer to the certified drawing.
- Water outlet for standard unit - for options 5, 6, 100A, 100C, 107 refer to the certified drawing.
-))) Air outlet – do not obstruct
- Power supply and control connection

NOTES:

- Drawings are not contractually binding.
- Before designing an installation, consult the certified dimensional drawings, available on request.
- If the installation includes several units or if this (these) is (are) close to walls, please refer to chapters 3.13 - "Multiple chiller installation" and 3.14 - "Distance to the wall" of the installation manual to determine the space required.

DIMENSIONS / CLEARANCES

30XBP500, 30XB500 with options 254/255, 50 (heat recovery) or 118A (free cooling)

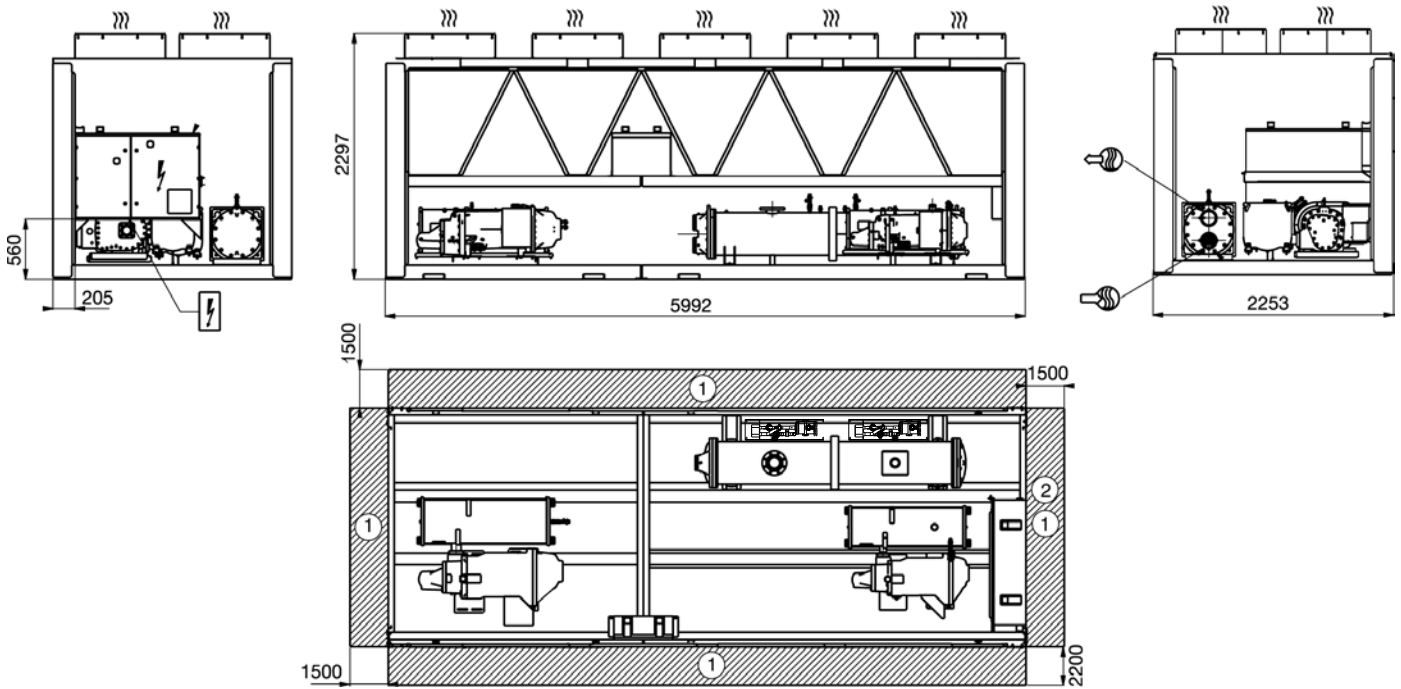



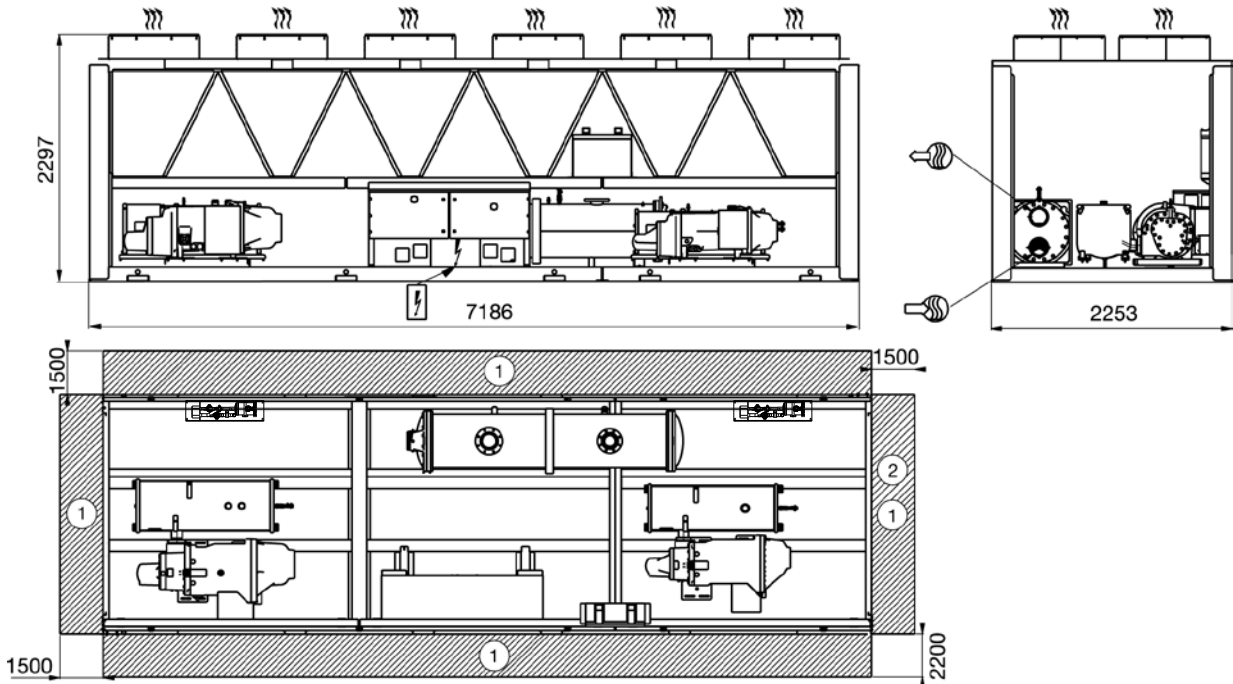

30XB600 to 900, 30XBP600 to 800, 30XB600 to 700 with option 254/255



Legend

All dimensions are given in mm.

- ① Required clearances for maintenance (see note)
- ② Recommended space for evaporator tube removal
-  Water inlet for standard unit - for options 5, 6, 100A, 100C, 107 refer to the certified drawing.
-  Water outlet for standard unit - for options 5, 6, 100A, 100C, 107 refer to the certified drawing.
-  Air outlet – do not obstruct
-  Power supply and control connection

NOTES:

- Drawings are not contractually binding.
- Before designing an installation, consult the certified dimensional drawings, available on request.
- If the installation includes several units or if this (these) is (are) close to walls, please refer to chapters 3.13 - "Multiple chiller installation" and 3.14 - "Distance to the wall" of the installation manual to determine the space required.

DIMENSIONS / CLEARANCES

30XB1000, 30XBP850 to 900, 30XB750 to 850 with option 254/255

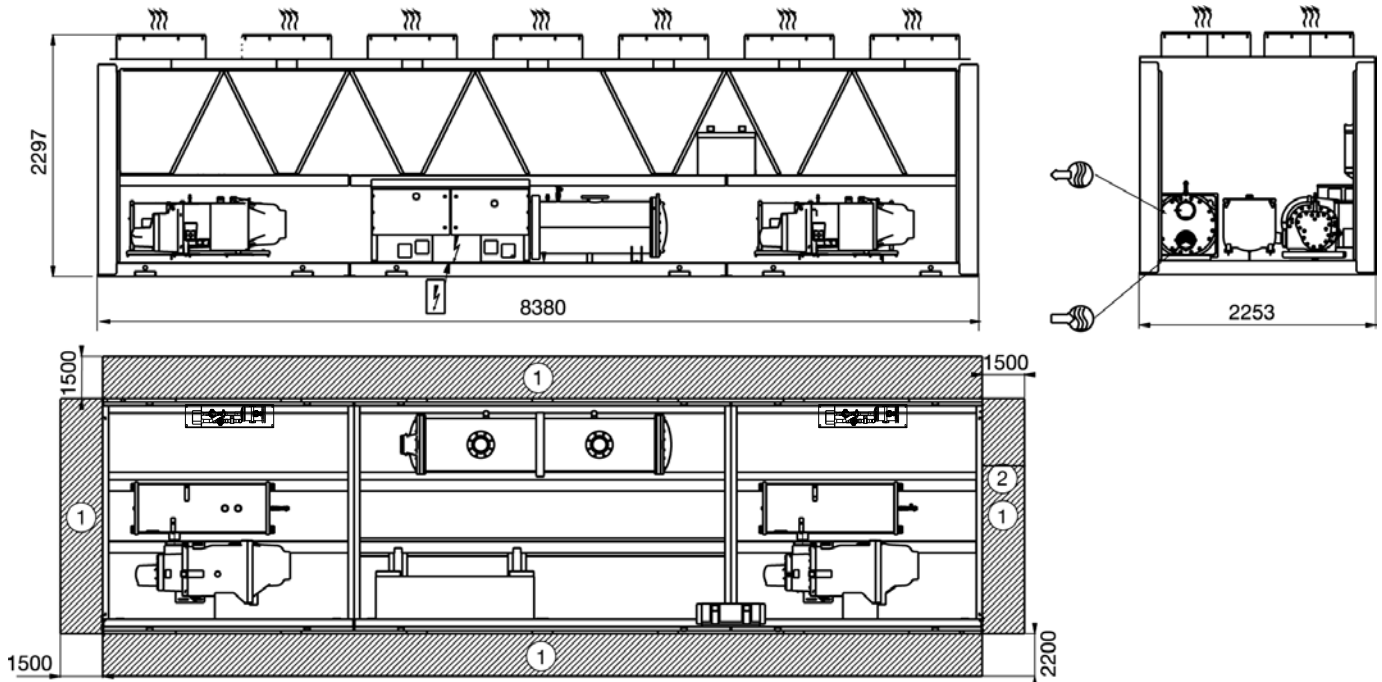

30XBP1000, 30XB900 option 254/255,
30XB1000 with options 50 (heat recovery) & 118 (free cooling)

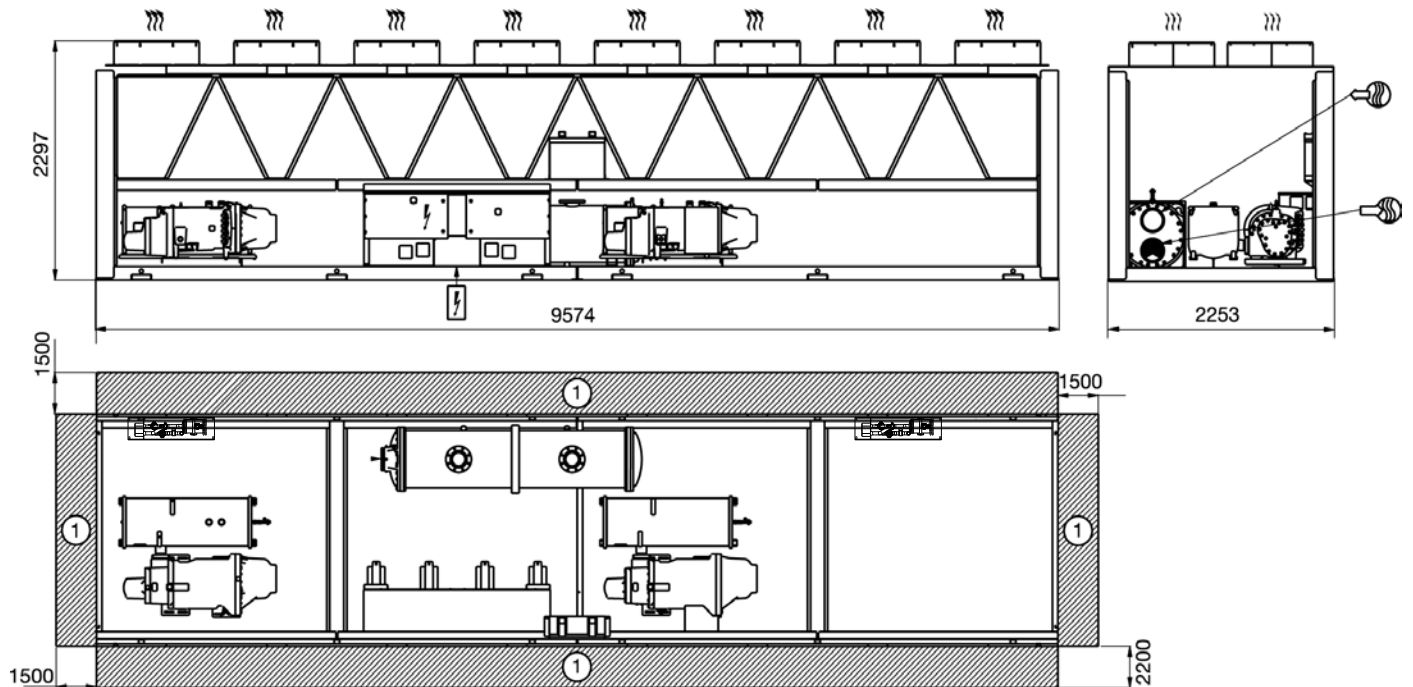

Legend

All dimensions are given in mm.

- ① Required clearances for maintenance (see note)
- ② Recommended space for evaporator tube removal
- Water inlet for standard unit - for options 5, 6, 100A, 100C, 107 refer to the certified drawing.
- Water outlet for standard unit - for options 5, 6, 100A, 100C, 107 refer to the certified drawing.
- Air outlet – do not obstruct
- Power supply and control connection

NOTES:

- Drawings are not contractually binding.
- Before designing an installation, consult the certified dimensional drawings, available on request.
- If the installation includes several units or if this (these) is (are) close to walls, please refer to chapters 3.13 - "Multiple chiller installation" and 3.14 - "Distance to the wall" of the installation manual to determine the space required.

DIMENSIONS / CLEARANCES

30XB1100 to 1400, 30XP1100 to 1400

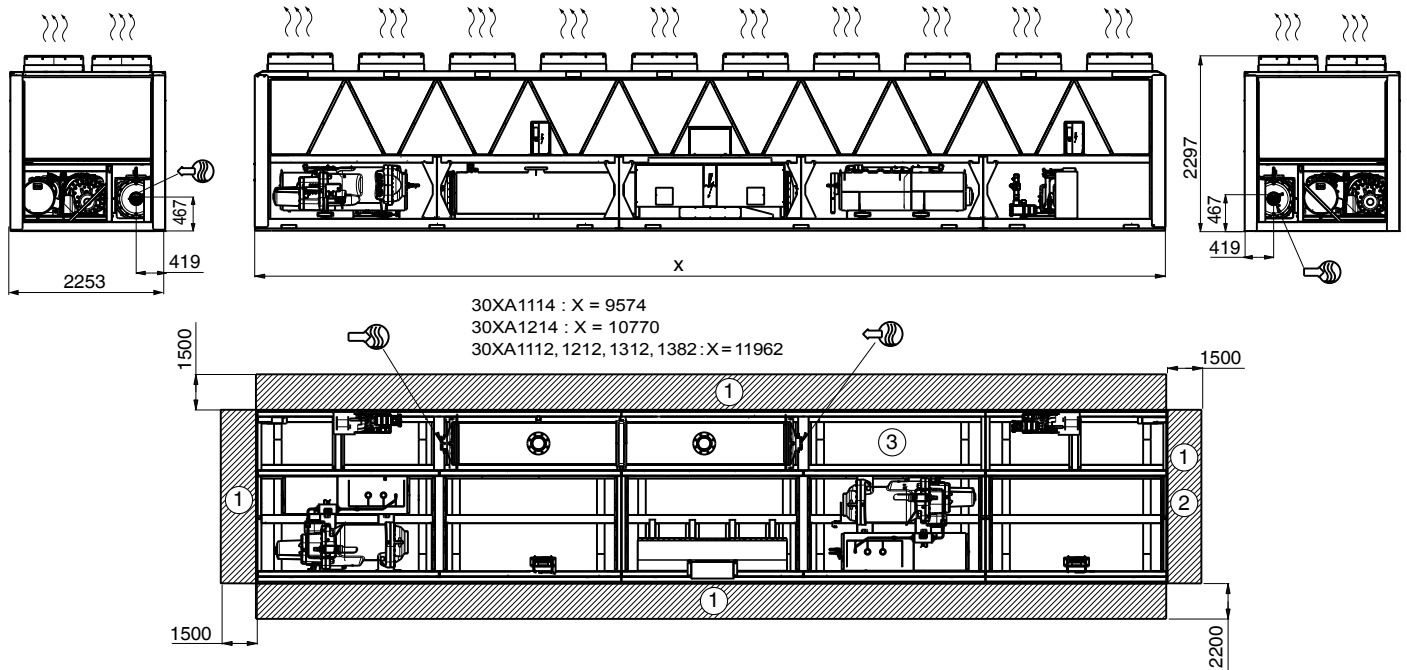

30XB1500, 30XP1500

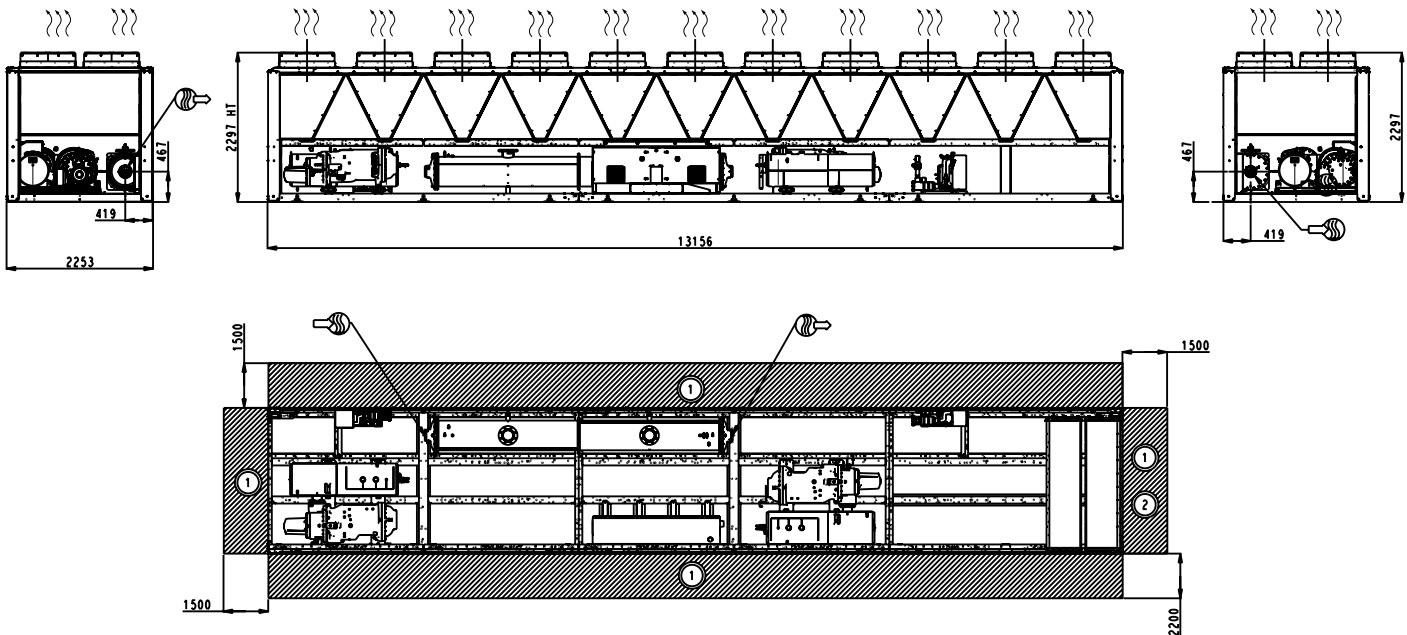

Legend

All dimensions are given in mm.

- ① Required clearances for maintenance (see note)
- ② Recommended space for evaporator tube removal
- Water inlet for standard unit - for options 5, 6, 100A, 100C, 107 refer to the certified drawing.
- Water outlet for standard unit - for options 5, 6, 100A, 100C, 107 refer to the certified drawing.
- Air outlet – do not obstruct
- Power supply and control connection

NOTES:

- Drawings are not contractually binding.
- Before designing an installation, consult the certified dimensional drawings, available on request.
- If the installation includes several units or if this (these) is (are) close to walls, please refer to chapters 3.13 - "Multiple chiller installation" and 3.14 - "Distance to the wall" of the installation manual to determine the space required.

DIMENSIONS / CLEARANCES

30XB1550 module 1/2

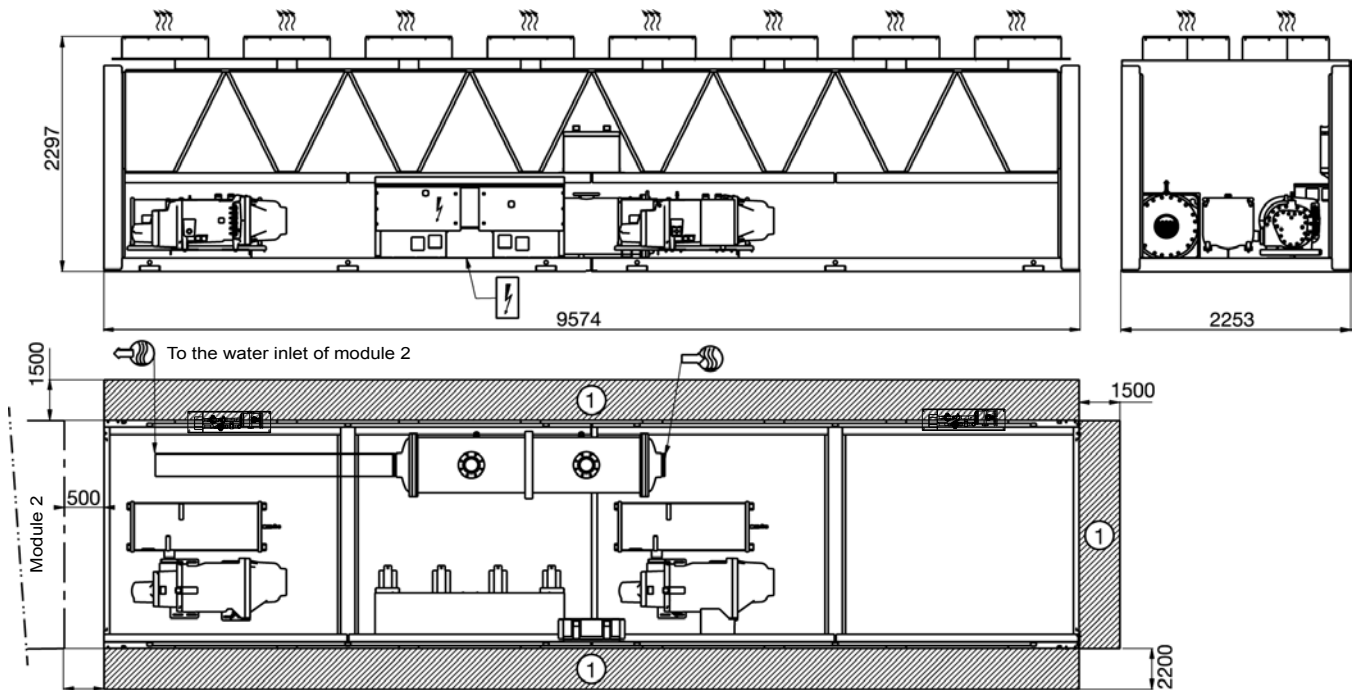

30XB1550 module 2/2

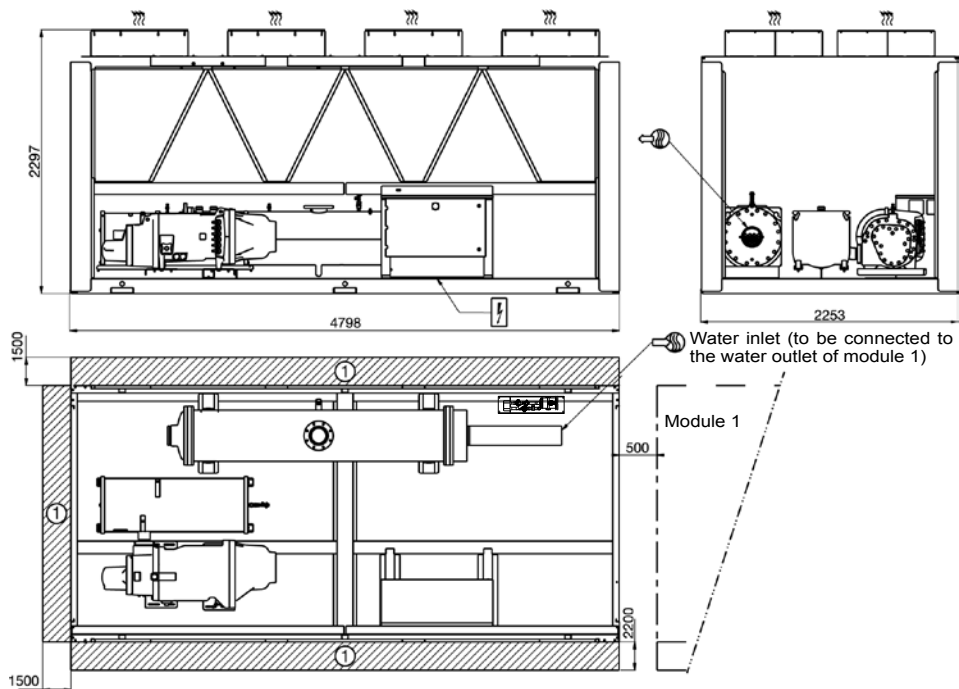

Legend

All dimensions are given in mm.

- ① Required clearances for maintenance (see note)
- ② Recommended space for evaporator tube removal
- ⊕ Water inlet for standard unit - for options 5, 6, 100A, 100C, 107 refer to the certified drawing.
- ⊖ Water outlet for standard unit - for options 5, 6, 100A, 100C, 107 refer to the certified drawing.
-))) Air outlet – do not obstruct
- ⚡ Power supply and control connection

NOTES:

- Drawings are not contractually binding.
- Before designing an installation, consult the certified dimensional drawings, available on request.
- If the installation includes several units or if this (these) is (are) close to walls, please refer to chapters 3.13 - "Multiple chiller installation" and 3.14 - "Distance to the wall" of the installation manual to determine the space required.

DIMENSIONS / CLEARANCES

30XB1700 module 1/2

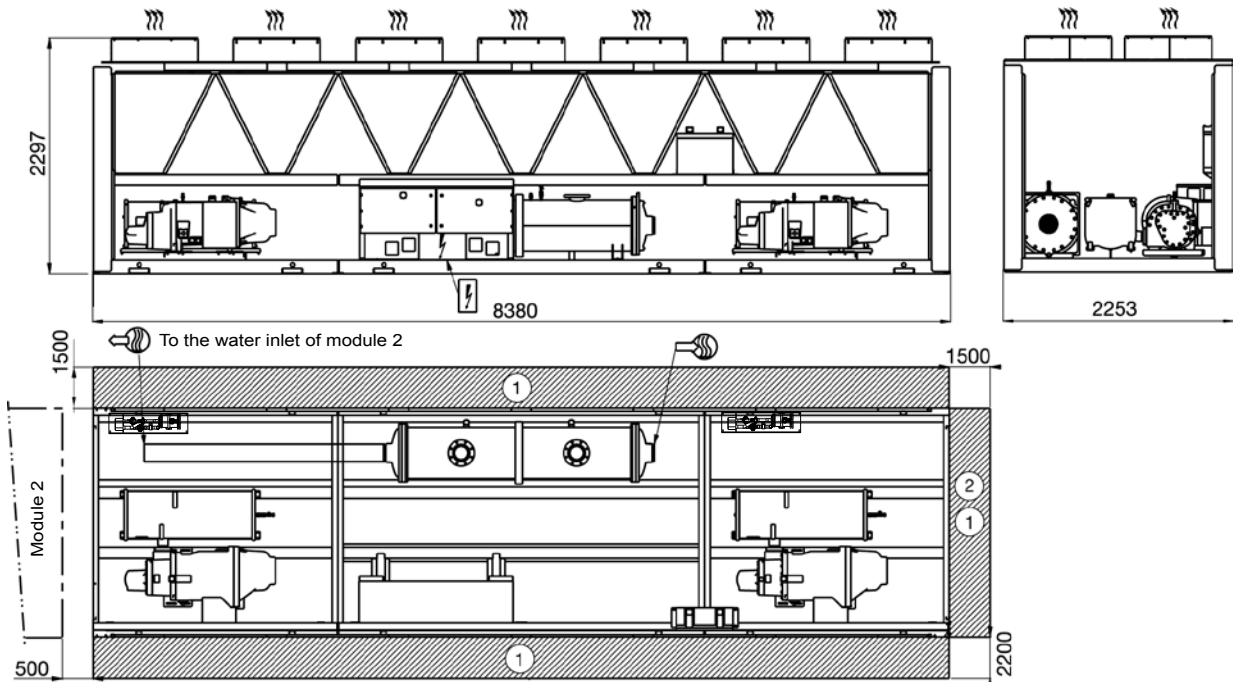



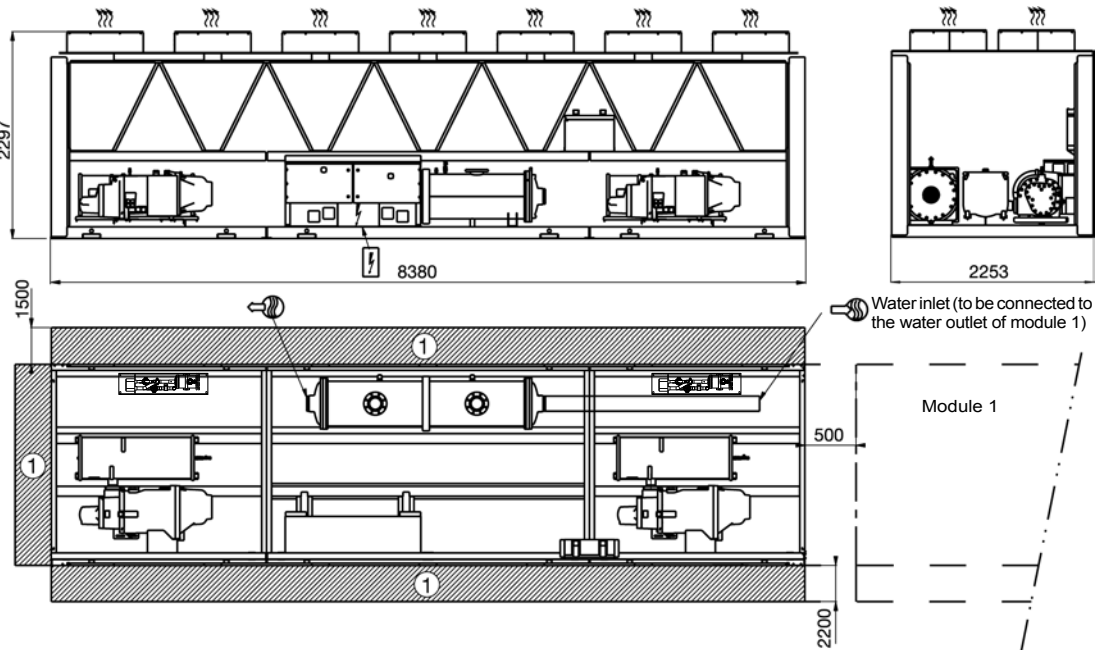

30XB1700 module 2/2



Legend

All dimensions are given in mm.

- ① Required clearances for maintenance (see note)
- ② Recommended space for evaporator tube removal
-  Water inlet for standard unit - for options 5, 6, 100A, 100C, 107 refer to the certified drawing.
-  Water outlet for standard unit - for options 5, 6, 100A, 100C, 107 refer to the certified drawing.
-  Air outlet – do not obstruct
-  Power supply and control connection

NOTES:

- Drawings are not contractually binding.
- Before designing an installation, consult the certified dimensional drawings, available on request.
- If the installation includes several units or if this (these) is (are) close to walls, please refer to chapters 3.13 - "Multiple chiller installation" and 3.14 - "Distance to the wall" of the installation manual to determine the space required.

SPECIFICATION GUIDE

General description

Factory assembled single piece air-cooled chiller, shall include all factory wiring, piping, controls, refrigerant charge (R134a), completely independent refrigerant circuits, screw compressors, electronic expansion valves and equipment required prior to field start-up.

The unit performance shall be certified by Eurovent or AHRI independent testing laboratory.

The unit shall operate at full load up with ambient temperatures ranging from -20°C to 48°C without tripping and without the use of additional adiabatic systems.

Quality assurance

Unit shall be rated in accordance with EN14511, EN14825 and AHRI 550/590 standards, latest revisions, and unit performance shall be certified by independent certification body.

- Unit without independent Eurovent or AHRI certification shall be excluded.
- Unit construction shall comply with European directives:
- From 1st January 2018, commission regulation (EU) N°2016/2281 implementing Directive 2009/125/EC with regards to Eco-design requirements for comfort cooling chillers and process chillers.
- Commission regulation (EU) N°640/2009 implementing Directive 2009/125/EC with regards to Eco-design requirements for electrical motors
- From 1st January 2015, commission regulation (EU) N°547/2012 implementing Directive 2009/125/EC with regards to Eco-design requirements for water pumps (unit equipped with hydraulic module option)
- Pressurised equipment directive (PED) 2014/68/UE
- Machinery directive 2006/42/EC, modified
- Low voltage directive 2014/35/UE
- Electromagnetic compatibility directive 2014/30/UE, modified, and the applicable recommendations of European standards
- Machine safety: electrical equipment in machines, general requirements, EN 60204-1
- Electromagnetic compatibility emission EN61000-6-4
- Electromagnetic compatibility immunity EN61000-6-2
- Directive 2009/125/EC with regard to ecodesign requirements for fans driven by motors with an electric input power between 125 W and 500 kW
- Directive 2005/32/EC with regard to ecodesign requirements for electric motors
- (if pumps on board) Directive 2009/125/EC with regard to ecodesign requirements for water pumps

Unit shall be designed, manufactured and tested in a facility with a quality management system certified ISO 9001 and environmental management system ISO 14001.

Unit shall be run tested at the factory.

Design performance data following European EN14825 & EN14511 standards

- Cooling capacity (kW):
- Unit power input (kW):
- Part load energy efficiency, SEER (kW/kW):
- Part-load energy efficiency, SEPR (kW/kW):
- Full load energy efficiency, EER (kW/kW):
- Eurovent Class
- Evaporator entering/leaving water temperature (°C): ... /
- Fluid type:
- Fluid flow rate (l/s):
- Evaporator pressure drops (kPa):
- Outdoor air temperature (°C):
- Sound power level at full load (dB(A)):
- Dimensions, length x depth x height (mm): ... x ... x

Performance shall be declared in accordance either with EN14511-3:2013 and certified by Eurovent or with AHRI 550/590 standard and certified by AHRI.

The unit shall operate at full load with ambient temperatures ranging from -10°C to 48°C without use of additional adiabatic cooler systems, with evaporator leaving liquid temperature between 3.3°C and 7°C. When evaporator leaving water temperature is higher than 7°C, up to 15°C, the maximum outdoor air temperature may be lower to secure machine safe operation. The machine shall continue to operate (at reduced capacity) in ambient temperatures of up to 55°C, with evaporator leaving liquid temperature between 3.3°C and 10°C.

- (Carrier option 5) Chilled brine solution production down to -10°C when ethylene glycol is used, or down to -6°C when propylene glycol is used.
- (Carrier option 6) Chilled brine solution production down to -15°C when ethylene glycol is used, or down to -10°C when propylene glycol is used.
- (Carrier option 28 or 17) The unit shall operate at full load down to -20°C ambient air temperature.

Frame

- Machine frame and enclosure shall be made of galvanised sheet steel
- Frame and enclosure shall be painted in oven-baked polyester powder paint in light grey colour (RAL 7035)
- Removable panels and electrical panel doors shall be accessible by 1/4-turn screws
- (Carrier option 23) Machine shall be protected from foreign bodies through the use of metal grilles factory-mounted on the four vertical faces. Coils refrigerant connections shall be covered by side panels of galvanised sheet steel, for enhanced aesthetic and safety during transportation.
- (Carrier option 23A) Coils refrigerant connections shall be covered by side panels of galvanised sheet steel, for enhanced aesthetic and safety during transportation.

SPECIFICATION GUIDE

Compressor

- Unit shall have semi-hermetic twin-screw compressors with internal relief valve and check valve to avoid reverse rotation on shut down
- Unit shall be equipped with a muffler to reduce discharge gas pulsations
- Compressor bearings shall be designed for minimum 73000 hours at maximum operating conditions
- Capacity control shall be provided by a slide valve
- Compressor capacity control shall be stepless from 100% to 30% load
- Compressor shall start in unloaded condition
- Motor shall be cooled by suction gas and protected by a dedicated electronic board against:
- Thermal overload by internal winding temperature sensors
- Electrical overload and short circuit by dedicated fuses (one per phase)
- Reverse rotation
- Loss of phase
- Undervoltage and power supply failure.
- Lubrication oil system shall include pre-filter and external filter capable of filtration to 5 microns
- The oil filter line shall be equipped with service shut off valves for easy filter replacement
- The oil separator, separate from the compressor, shall not require oil pump and shall include an internal muffler to reduce discharge gas pulsations
- The oil separator shall be designed for 2100 kPa working pressure
- The oil separator shall include a temperature actuated heater and an oil level safety switch
- Compressors shall be installed on flexible anti-vibration mounts and isolated from the main unit chassis
- (Carrier option 93A) Each compressor shall be equipped with a discharge shut-off valve
- (Carrier option 279A) Each compressor and oil separator shall be installed within an enclosure with removable panels to facilitate service access
- (Carrier option 15 or 15LS) Each compressor shall be installed within an insulated acoustic enclosure with removable panels to facilitate service access.

Evaporator

- Unit shall be equipped with a single flooded evaporator
- Evaporator shall be manufactured by the chiller manufacturer
- Evaporator shall be tested and stamped in accordance with the European directive for pressurised equipment 2014/68/UE
- The maximum refrigerant-side operating pressure will be 2100 kPa, and the maximum waterside pressure will be 1000 kPa (2100kPa as an option)
- The evaporator shall be mechanically cleanable, shell-and-tube type with removable heads
- Tubes shall be internally and externally grooved, seamless-copper, and shall be rolled into tube sheets
- Shell shall be insulated with 19 mm closed-cell foam with a maximum K factor of 0.28. Evaporator thermal insulation shall be factory fitted
- The evaporator shall have a drain and vent in each head
- Chiller shall have only one water inlet & outlet connection with Victaulic couplings to avoid vibrations transmission and to accommodate minor pipework misalignment (Victaulic adapter kit shall be available on demand)
- Design shall incorporate 2 independent refrigerant circuits

- Evaporator shall be fitted with electronic auto setting water flow switch. Paddle switches or differential pressure switches shall not be acceptable
- (Carrier option 281) Unit shall be fitted with a cooler jacket to protect the insulation from the long-term effects of UV radiation.

Condenser

- Condenser coils shall be designed to ensure sub-cooling of the liquid refrigerant
- Condenser coils shall be V-shaped with a minimum open angle of 50° to ensure optimum air distribution
- Coils shall be entirely made of aluminium alloy, micro-channels type.
- Coils shall consist of a two-pass arrangement
- Coils shall be leak-tested at 15.5 bar with 100% He
- (Carrier options 254/255) Coils shall use copper tubes and aluminium fins
- (Carrier option 262) Coils shall be suitable for installations in moderately corrosive environment. The protection shall consist on a nano-scale conversion coating, 100 to 200 nm thick, which uniformly covers the entire surface of the coil. Non conversion coating shall not be accepted. The coating process shall include immersion in a coating bath. The coating shall be applied by an autocatalytic conversion process which shall modify the surface of the aluminum producing a coating that is integral to the coil. Complete immersion shall ensure that 100% of the surface is coated, forming a continuous and even film. Spray coating process shall not be accepted. The coating shall be integral to the Novation™ MCHE and shall not flake or loose adhesion with cross hatch adhesion of 5B per ASTM D3359. The thin coating shall have no effect on heat transfer or air flow per ARI 410. The coating shall utilise corrosion inhibitors which actively arrest damage due to environmental or mechanical damage. Corrosion durability of coated microchannel coils shall be confirmed through testing to no less than 5000 hours constant neutral salt spray per ASTM B117.
- (Carrier option 263) Coils shall be suitable for installations in the most severe environments. The protection shall consist of a flexible epoxy polymer coating uniformly applied to all coil external surface areas without material bridging between fins. The coating shall be applied by an electrocoating process with immersion in a coating bath and a final UV protective topcoat to shield the fins from ultraviolet degradation and to ensure coating durability and long life. Spray coating and non-electrocoating shall not be accepted. Coating process shall ensure complete coil encapsulation, including all exposed fin edges. The coating shall have a uniform thickness of 20 to 40 µm on all external coil surface areas including fin edges. The coating shall have minimal effect (<1%) on heat transfer or air flow per ARI 410. The coating shall have superior hardness characteristics of 2H per ASTM D3363 and cross hatch adhesion of 4B-5B per ASTM D3359. Impact resistance shall be up to 100 in/lb (ASTM D2794). Corrosion durability of coated microchannel coils shall be confirmed through testing to no less than 5000 hours constant neutral salt spray per ASTM B117.

SPECIFICATION GUIDE

Fans

- (30XB standard unit) Fans shall be fixed-speed AC fans
- (30XB with option 17) Fans shall be variable-speed AC fans with one or more variable-speed drives per refrigerant circuit.
- (30XBP premium unit) Fans shall be EC fans.
- Fans shall be direct-drive, equipped with an impeller with 9 aerodynamic blades and a rotating shroud to ensure optimal leak-tightness between the blades and the fan housing
- Fans impellers shall be of one-piece and made of a corrosion-resistant composite material, and statically and dynamically balanced
- The fans discharges shall be protected by polyethylene-coated steel wire grilles
- The three-phase electric motors shall have isolation class F, IP 55 protection and a minimum efficiency of 80%. They shall have individual overload protection via a disconnect switch
- (Carrier option 10) Fans shall be equipped with discharge connection flanges increasing available discharge pressure up to 60 kPa
- Noise levels shall be adjustable electronically per time band on user display to guarantee a quiet operation during night or building unoccupied periods.

Refrigerant circuit

- Refrigerant circuit components shall include: compressor, oil separator, high and low side pressure relief devices, economiser, filter driers, moisture indicating sight glasses, long stroke electronic expansion device, and complete operating charge of both refrigerant R134a and compressor oil
- (Carrier option 92) For each refrigerant circuit, a compressor suction and discharge line shut off valve, an evaporator inlet valve and economiser line valve, shall be mounted to isolate all main components (filter drier, oil filter, expansion device and compressor) and allow refrigerant to be safely stored during service operation
- (Carrier option 93A) Each compressor shall be equipped with a discharge shut-off valve
- (Carrier option 257) Compressor and oil separator sub-assembly and refrigerant gas suction line shall be acoustically insulated
- (Carrier option 258) Compressor and oil separator sub-assembly, refrigerant gas suction line and the economiser subassembly (if needed) shall be acoustically insulated.

Power control boxes

- Unit shall operate at 400 Volts (+/- 10%), 3-phases, 50 Hertz power supply without neutral
- Unit shall be designed for simplified connection on TN(s) networks
- Unit shall have maximum holding short circuit current of 38000 Amps up to 500 kW, of 50000 Amps up to 1000 kW and 100000 Amps up to 1700 kW nominal cooling capacity
- Control circuit voltage shall be 24 V maximum, supplied by a factory-installed transformer
- Unit shall be supplied with factory-installed main circuit breaker/isolator
- Unit shall have a factory installed star/delta starter as standard to limit electrical inrush current
- Power control box is powder painted with hinged and gasket sealed doors and is protected to IP44CW
- (Carrier option 20A) The power control box shall be protected to IP54 to permit safe operation for installations in polluted environment

- (Carrier option 70D) The main electrical disconnect switch shall integrate fuses for protection against over current flow
- (Carrier option 81 for sizes 1102/1502, standard for all other sizes) Unit shall have single point power connection
- (Carrier option QM231) The unit shall include capacitors to ensure a power factor of 0.95 at full load.

Controls

- Unit control shall include as a minimum: microprocessor with non-volatile memory, picture guided unit/operator interface, the LOCAL/OFF/REMOTE/CCN selector and a 5 inch coloured touch-screen display with 10 languages capability: German, English, Spanish, French, Italian, Dutch, Portuguese, Turkish, Russian and one additional language on customer choice (downloadable on job site)
- (Carrier option 158A) Unit control shall include as a minimum: microprocessor with non-volatile memory, picture guided unit/operator interface, the LOCAL/OFF/REMOTE/CCN selector and a 7 inch coloured touch-screen display with multiple language capability
- Pressure sensors shall be installed to measure suction, discharge, and oil pressure
- Temperature probes shall be installed to read cooler entering and leaving temperatures and outdoor air temperature
- Unit control shall have an IP port to permit user connection via web browser, allowing same level of access to control menus as unit mounted interface (excluding start/stop and alarm reset capabilities)
- Control shall store technical documentation, drawings and spare parts list specific to each particular unit
- (Carrier option 148B) A bi-directional communication board shall allow plug and play interfacing of the machine with any BMS using the J-Bus protocol
- (Carrier option 148D) A bi-directional communication board shall allow plug and play interfacing of the machine with any BMS using the LonTalk protocol
- (Carrier option 149) Machine shall be supplied with factory installed bi-directional high-speed communication using BACnet protocol over Ethernet network (IP-connection). The BACnet over-IP communication shall have no limitation in reading/writing controller points and shall use standardised alarm codes as defined with BACnet protocol. Field programming shall be required
- (Carrier option 298) Machine shall be accessible via wireless connection for remote monitoring to facilitate preventive maintenance.

Unit shall be capable of performing the following functions:

- Electronic expansion valve control optimising evaporator refrigerant charge while ensuring minimum refrigerant superheat and optimum subcooling at condenser outlet
- Capacity control based on leaving chilled fluid temperature
- Limitation of the chilled fluid-temperature pull-down rate at start-up to an adjustable range of 0.1°C to 1.1°C per minute to prevent excessive demand spikes at start-up
- Automatic change-over and cycling of compressors to equalise running hours and number of starts
- Reset enable of leaving chilled-water temperature based on the outdoor air temperature or via 0-10 V signal (as option)
- Dual set point management for the leaving chilled water temperature activated by a remote contact closure signal or by the built in time clock
- 2-level demand limit control (between 0 and 100%) activated by remote contact closure or by the built in time clock

SPECIFICATION GUIDE

- Time schedule management to enable unit start-up control, demand limit and set-point changes
- Trending of main variables (accessible by web browser only)
- (Carrier option 58) lead/lag type control of two chillers running in series or parallel
- (Carrier option 116) Evaporator pump control, including additional standby pump (if installed)
- (Carrier option 156) The following inputs contacts shall be available on the unit control board:
 - Setpoint reset by indoor air temperature sensor
 - Cooling setpoint reset by 4-20 mA
 - Time schedule override
 - Ice storage input
 - Demand limit
 - Unit shut down

The following outputs contacts shall be available on the unit control board:

- Instantaneous chiller capacity by 0-10 V signal
- Complete shut-down due to a chiller fault
- Compressor operation indication.

Diagnosis

- Control interface shall be capable of displaying set points, system status including temperatures, pressures, current for each compressor, run time and percent loading
- Control interface shall perform trending of up to 10 preselected variables
- Control system shall allow a quick test of all machine elements to verify the correct operation of every switch, circuit breaker, contactor etc. before the chiller is started
- In case of alarm, control system shall send an email to specific mail box set by user during machine commissioning
- Control shall have a black box function capable of storing a data set of 20 variables, at intervals of 5 seconds, for 14 minutes preceding the alarm and 1 minute after the alarm. The black box shall be able to record 20 events. Once this threshold is reached, new data shall over-write the oldest record.

Refrigerant leak alert:

The liquid chiller shall be equipped as standard with an automatic refrigerant leak detection algorithm:

- Indicates serious refrigerant loss from any point in the system.
- Sensitivity: 25% refrigerant charge loss per circuit (depending on the conditions).
- Refrigerant leak detection (option 159):
- Available as an option, an additional dry-contact shall allow reporting of possible leaks. The leak detector (by others) should be mounted in the most likely leak location.

Safeties

Control system shall provide the unit with protection against the following:

- Reverse rotation
- Low chilled water temperature
- Low oil pressure (per compressor)
- Current imbalance
- Compressor thermal overload
- High pressure (with automatic compressor unloading in case of excessive condensing temperature)
- Electrical overload and short circuit
- Loss of phase, undervoltage and power supply failure
- Control shall provide separate general alert (minor incident) and alarm (circuit down) remote indication.

Hydraulic module (optional)

(Carrier 30XB and 30XBP 250 to 500 option 116B/C/F/G) A choice of different pump types and configurations shall be available:

- Single high-pressure pump
- Dual high-pressure pumps
- Single low-pressure pump
- Dual low-pressure pumps

If dual pumps are fitted, the unit control shall automatically manage the change-over and cycling of pumps to equalise running hours and number of starts

The hydraulic module shall be integrated in the chiller chassis without increasing its dimensions

The hydraulic module shall include the following elements:

- Removable screen filter
- Centrifugal monocell water pump with three-phase motor equipped with internal over-temperature protection
- Electronic water flow switch without paddle
- Relief valve calibrated to 4 bar
- Long stroke flow control valve
- Pressure gauge and valve set for differential pressure measurement
- The water pump shall be isolated from the chiller structure and water piping by anti-vibration mountings and expansion compensators, in order to limit vibration and noise transmission
- The water piping shall be protected against corrosion and equipped with drain and purge plugs
- The hydraulic connections shall be Victaulic type
- Both pump and piping shall be fully insulated with polyurethane foam clad with aluminum to prevent condensation
- (Carrier option 41B) Pump frost protection shall be guaranteed down to -20°C by electric resistance heaters
- Piping frost protection shall be guaranteed down to -20°C by automatic pump activation when liquid temperature falls below a safety limit

Total heat recovery (optional)

(Carrier option 50) The unit shall include an additional heat exchanger in parallel with the condenser coils to recover 100% of condenser heat

Dx Free-cooling (optional)

(Carrier option 118A) The unit shall include one additional refrigerant pump on each refrigerant circuit to provide partial free-cooling during the cold season. The free-cooling option shall not require the addition of glycol to the water loop.



Order No.: 10204, 09.2017. Supersedes order No.: New.
Manufacturer reserves the right to change any product specifications without notice.



Quality and Environment
Management Systems
Approval

Manufactured by: Carrier SCS, Montluel, France.
Printed in the European Union.