



United Technologies

PRODUCT SELECTION DATA



- HIGH FULL AND PART-LOAD EFFICIENCY
- COMPACT AND SIMPLE TO INSTALL
 - LOW SOUND LEVEL
- LOW REFRIGERANT CHARGE
 - SUPERIOR RELIABILITY

Unit with low noise level option

Air-to-Water Scroll Heat Pump with
Greenspeed® Intelligence

30RQM/30RQP 160-520

Nominal heating capacity 179-434 kW 50 Hz



CARRIER participates in the ECP programme for LCP/HP
Check ongoing validity of certificate:
www.eurovent-certification.com 
www.certiflash.com

AQUASnap greenspeed

30RQM/30RQP 160-520

Nominal heating capacity 179-434 kW

Nominal cooling capacity 156-511 kW

The Aquasnap heat pumps are the best value solution for commercial and industrial applications where installers, consultants and building owners require reduced installed costs, optimal performances and maximum quality.

The new generation Aquasnap features two new versions:

- The Aquasnap (30RQM) version features a compact all-in-one package optimised for full-load applications where reduced investment cost (low Capex) is required.
- The Aquasnap Greenspeed® (30RQP) version features a compact all-in-one package optimised for part-load applications where high SCOP and SEER are required. The Aquasnap Greenspeed® equipped with variable speed fans and variable speed pump provides premium part load efficiency to reduce utility costs over the lifespan of the heat pump. Additionally, the low sounds levels achieved at part load conditions can be very beneficial for sensitive acoustic applications.

The Aquasnap heat pumps are designed to meet current and future Ecodesign and F-Gas European regulation requirements in terms of energy efficiency and reduced CO₂ emissions. They use the best technologies available today:

- Reduced refrigerant charge of ozone-friendly R-410A refrigerant
- Scroll compressors
- Greenspeed® variable-speed driven fans (30RQP models)
- Brazed plate heat exchangers with reduced pressure drops
- Auto-adaptive microprocessor control with Greenspeed® intelligence
- Touch Pilot control with web connectivity possibilities and colour touch screen user display
- Extra energy savings through partial heat recovery (Option available during 2015).

Both Aquasnap versions can be equipped with an integrated hydronic module, limiting the installation to conventional operations such as connection of the power supply and the supply and return piping (plug & play), according to the dimensions of the standard unit.

Recommended by Carrier, Aquasnap can be equipped with one or two Greenspeed® variable-speed pumps to significantly reduce energy costs linked to pumping (reduction of more than two-thirds), ensure optimum water flow rate control, and improve overall system reliability.



Features and benefits

Highly economical operation

- High unit full and part load energy efficiency and efficient design of the water side:
 - Standardised Eurovent values in accordance with EN 14511-3:2013 EER up to 2.9 and ESEER up to 4.35 (30RQP version)
 - 30RQP and 30RQM ranges are compliant with EU Eco-design Tier 1 Minimum Efficiency Performance Standards (MEPS) in heating that apply from September 2015
 - 30RQP range and 30RQM sizes 430-470-520 are compliant with EU Eco-design Tier 2 MEPS in heating that apply from September 2017
 - Multiple scroll compressors equipped with a high-efficiency motor that permit exact matching of the capacity to the load
 - Electronic expansion device permitting operation at a lower condensing pressure and improved utilisation of the evaporator heat exchange surface (superheat control)
 - Air heat exchanger with Greenspeed® variable speed fans (30RQP version)
 - Low pressure drop brazed plate heat exchangers (pressure drops < 45 kPa at Eurovent conditions).
- Specific control functions to reduce unit energy use during occupied and unoccupied periods:
 - Internal timer programming: Permits heat pump on/off control and operation at a second setpoint
 - Setpoint automatically offset based on the outside air temperature or room air temperature (via an option)
 - Floating high-pressure management
 - Variable-speed fan control
 - Cooling and heating demand limitation.Refer to control chapter for more information.
- Greenspeed® variable-speed pump to reduce pumping energy use up to 2/3 (option recommended by Carrier):
 - Eliminate energy losses through the water flow rate control valve by electronically setting the nominal water flow rate
 - Save energy during stand-by periods or part-load operation by automatically reducing the water pump speed. The energy consumption of the pump motor varies according to the cube of the speed, so that a reduction in speed of just 40% can reduce energy consumption by 80%
 - Improved unit part-load performance (Increased SCOP and SEER values with variable water flow rate as per the EN14825 standard).

Refer to hydronic option chapter for more information.



Extra energy savings through partial heat recovery option that permits free hot water production.

Reduced maintenance costs

- Fast diagnosis of possible incidents and their history via the control
- R-410A refrigerant is easier to use than other refrigerant blends.

Low sound level

Coil section with fixed speed fans (30RQM models):

- Condenser coils in V-shape with an open angle, allowing quieter air flow across the coil
- Low-noise 4th generation Flying Bird fans, made of a composite material (Carrier patent)
- Rigid fan installation for reduced noise (Carrier patent).

Coil section with Greenspeed® variable-speed fans (30RQP models recommended by Carrier for even quieter operation):

- Exceptional acoustic signature during part-load operation through smooth fan speed variation.

- Specific control functions or features to reduce noise level during night or unoccupied periods:
 - Night time sound control with capacity and fan speed limitation
 - Low-noise scroll compressors with low vibration level
 - The compressor assembly is installed on an independent chassis and supported by flexible anti-vibration mountings.
 - Dynamic suction and discharge piping support, minimising vibration transmission (Carrier patent)
 - Acoustic compressor enclosure, reducing radiated noise emissions (option).



Quick and easy installation

- Compact design
 - The Aquasnap units are designed to offer compact dimensions and low weight for easy installation.
- Integrated hydronic module (option)
 - Low or high-pressure water pump (as required)
 - Single or dual pump (as required) with operating time balancing and automatic changeover to the back-up pump if a fault develops
 - Water filter protecting the water pump against circulating debris
 - Pressure transducers for direct numerical display of the water flow rate and water pressures
 - Thermal insulation and frost protection down to -20 °C, using an electric resistance heater (option)
 - High-capacity membrane expansion tank (option).
- Integrated hydronic module with Greenspeed® variable-speed pump (option recommended by Carrier)
 - Quick and easy electronic setting of the nominal water flow rate when the unit is commissioned, thus eliminating the need to adjust the water flow rate control valve
 - Automatic control of the pump speed based on constant speed, constant pressure difference or constant temperature difference.

Simplified electrical connections

- A single power supply point without neutral
- Main disconnect switch with high trip capacity
- 24 V control circuit without risk from a transformer included.
- Fast unit commissioning
 - Systematic factory test before shipment
 - Quick-test function for step-by-step verification of the sensors, electrical components and motors.

Reduced installation costs

- Optional Greenspeed® variable-speed pump with hydronic module (option recommended by Carrier)
 - Elimination of the water flow control valve cost
 - Water system design with variable primary flow (VPF) can provide significant installation cost savings compared with traditional constant primary-variable secondary systems; elimination of the secondary distribution pump, etc.
 - Water system design with fan coils fitted with 2-way valves instead of 3-way valves.

Environmental responsibility

- R-410A ozone-friendly refrigerant.
- Reduced direct warming potential (10% of total equivalent warming impact):
 - Low R410-A refrigerant charge
 - Leak-tight refrigerant circuit with minimum brazed connections
 - Qualified Carrier maintenance personnel to provide refrigerant servicing
 - ISO 14001 manufacturing site.
- Reduced indirect warming potential (90% of total equivalent warming impact):
 - Reduced unit energy use (high full- and part-load efficiency)
 - Pumping energy consumption can be reduced by up to 2/3 using Greenspeed® variable-speed pumps.

Superior reliability

- State-of-the-art concept
 - Two independent refrigerant circuits; the second one automatically takes over if the first one develops a fault, maintaining partial cooling under all circumstances
 - All compressor components are easily accessible on site, minimising downtime
 - V-coil design to protect the coils against hail impact
 - Optional anti-corrosion coil coating for use in moderately corrosive environments.
 - Electronic flow switch. Auto-setting according to cooler size and fluid type
- Auto-adaptive control
 - Control algorithm prevents excessive compressor cycling and reduces the quantity of water in the water loop (Carrier patent)
 - Automatic compressor unloading in case of abnormally high condensing pressure
 - Automatic fan speed adjustment in case of coil fouling (30RQP models)
 - Smooth fan start to increase unit lifetime (30RQP models).
- Exceptional endurance tests
 - Partnerships with specialised laboratories and use of simulation tools (finite element analysis) for the design of critical components
 - Transport simulation test on an endurance circuit based on a military standard.

Touch Pilot Control

The Touch Pilot features a control with advanced communication technology over Ethernet (IP), user-friendly and intuitive user interface with 5" colour touch screen.

- Energy management configuration
 - Internal time schedule clock: Controls heat pump on/off times and operation at a second set-point
 - Setpoint offset based on the outside air temperature
 - Master/slave control of two heat pumps operating in parallel with operating time equalisation and automatic change-over in case of a unit fault.
- Advanced communication features
 - Night mode: Capacity and fan speed limitation for reduced noise level
 - With hydronic module: Water pressure display and water flow rate calculation
 - High-speed user-friendly communication technology over Ethernet (IP) to a centralised building management system
 - Access to multiple unit parameters.
- Functionality of maintenance
 - Compulsory maintenance reminder– FGAS sealing check
 - Periodic maintenance reminder Maintenance alarm which can be configured to days, months or hours of operation
- 5-inch Touch Pilot user interface



- Intuitive and user-friendly 5 inch touch screen interface
- Concise and clear information is available in local languages
- Complete menu, customised for different users (end user, service personnel or Carrier engineers).

Remote management (standard)

Units with Touch Pilot control can be easily accessed from the internet, using a PC with an Ethernet connection. This makes remote control quick and easy and offers significant advantages for service operations.

The AquaSnap is equipped with an RS485 serial port that offers multiple remote control, monitoring and diagnostic possibilities. Carrier offers a vast choice of control products, specially designed to control, manage and supervise an air conditioning system. Please consult your Carrier representative for more information.

The AquaSnap also communicates with other centralised building management systems via optional communication gateways.

A connection terminal allows remote control of the Aquasnap by wired cable:

- Start/stop: Opening of this contact will shut down the unit
- Dual setpoint: closing of this contact activates a second setpoint (e.g.: unoccupied mode).
- Demand limit: Closing of this contact limits the maximum heat pump capacity to a predefined value.
- Operation indication: This volt-free contact indicates that the heat pump is operating (cooling load).
- Alarm indication: This volt-free contact indicates the presence of a major fault that has led to the shut-down of one or several refrigerant circuits.

Energy management module (option)

The Energy Management Module offers extended remote control possibilities:

- Room temperature: Permits set-point reset based on the building indoor air temperature (with Carrier thermostat)
- Set point reset: Ensures reset of the cooling set-point based on a 4-20 mA
- Demand limit: Permits limitation of the maximum heat pump power based on a 4-20 mA signal
- Demand limit 1 and 2: Closing of these contacts limits the maximum heat pump power or current to two predefined values.
- User safety: This contact can be used for any customer safety loop; opening the contact generates a specific alarm.
- Ice storage end: When ice storage has finished, this input permits return to the second set-point (unoccupied mode).
- Time schedule override: Closing of this contact cancels the time schedule effects.
- Out of service: This signal indicates that the heat pump is completely out of service.
- Unit capacity: This analogue output (0-10 V) gives an immediate indication of the unit capacity.
- Alert indication: This volt-free contact indicates the necessity to carry out a maintenance operation or the presence of a minor fault.
- Boiler control: This on/off output controls an independent boiler to provide hot water.
- Electric heater control: this on/off output controls up to 4 electric heater stages to provide additional heating capacity during the cold season.

Options

Options	No.	Description	Advantages	Use
Corrosion protection, traditional coils	3A	Fins made of pre-treated aluminium (polyurethane and epoxy)	Improved corrosion resistance, recommended for moderate marine and urban environments	30RQM/30RQP 160-520
Low temperature brine solution	6B	Low temperature chilled water production down to -8°C with ethylene or propylene glycol	Covers specific applications such as ice storage and industrial processes	30RQP 180-230-270-310
High static fans	12	Unit equipped with high static variable speed fan (maximum 200Pa), each fan being equipped with a connection flange allowing the connection to the ducting system.	Ducted fan discharge, optimised temperature control, based on the operating conditions and system characteristics	30RQM/30RQP 160-520
Low noise level	15	Aesthetic and sound absorbing compressor enclosure	Noise level reduction by 1 to 2 dB(A)	30RQM/30RQP 160-520
Very low noise level	15LS	Acoustic compressor enclosure and low-speed fans	Noise level reduction for sensible site	30RBM 160-520
IP54 control box	20A	Increased leak tightness of the unit	Protects the inside of the electrics box from dust, water and sand. In general this option is recommended for installations in polluted environments	30RQM/30RQP 160-520
Grilles and enclosure panels	23	Metal grilles on the 4 unit sides, plus side enclosure panels at each end of the coils	Improves aesthetics, protection against intrusion to the unit interior, coil and piping protection against impacts.	30RQM/30RQP 160-520
Enclosure panels	23A	Side enclosure panels at each end of the coil	Improves aesthetics, coil and piping protection against impacts.	30RQM/30RQP 160-520
Soft Starter	25	Electronic starter on each compressor	Reduced start-up current	30RQM/30RQP 160-520
Winter operation down to -20°C	28	Fan speed control of lead fan for each circuit using a variable frequency drive	Stable unit operation for outside air temperatures from 0°C down to -20°C in cooling mode	30RQM 160-520
Water exchanger frost protection	41	Electric heater on the water exchanger and the water piping	Water exchanger module frost protection between 0°C and -20°C outside air temperature	30RQM/30RQP 160-520
Exchanger & hydraulic frost protection	42A	Electric heater on the water exchanger hydronic module and optional expansion tank	Water exchanger and hydronic module frost protection down to an outside air temperature of -20°C	30RQM/30RQP 160-520
Partial heat recovery	49	Unit equipped with one desuperheater on each refrigerant circuit	Production of free high-temperature hot-water simultaneously with chilled water production (or hot water for Heat pump)	30RQM/30RQP 160-520
Master/slave operation	58	Unit equipped with supplementary water outlet temperature sensor kit to be field-installed allowing master/slave operation of two units connected in parallel	Optimised operation of two units connected in parallel operation with operating time equalisation	30RQM/30RQP 160-520
Compressor discharge valves	93A	Shut-off valves on the compressor discharge piping	Simplified maintenance. Possibility to store the refrigerant charge in the condenser side during servicing	30RQM/30RQP 160-520
HP single-pump hydronic module	116R	Single high-pressure water pump, water filter, electronic water flow control, pressure transducers. For more details, refer to the dedicated chapter (expansion tank not included. Option with built-in hydraulic safety components available)	Easy and fast installation (plug & play)	30RQM/30RQP 160-520
HP dual-pump hydronic module	116S	Dual high-pressure water pump, water filter, electronic water flow control, pressure transducers. For more details, refer to the dedicated chapter (expansion tank not included. Option with built-in hydraulic safety components available)	Easy and fast installation (plug & play)	30RQM/30RQP 160-520
LP single-pump hydronic module	116T	Single low-pressure water pump, water filter, electronic water flow control, pressure transducers. For more details, refer to the dedicated chapter (expansion tank not included. Option with built-in hydraulic safety components available)	Easy and fast installation (plug & play)	30RQM/30RQP 160-520
LP dual-pump hydronic module	116U	Dual low-pressure water pump, water filter, electronic water flow control, pressure transducers. For more details, refer to the dedicated chapter (expansion tank not included. Option with built-in hydraulic safety components available)	Easy and fast installation (plug & play)	30RQM/30RQP 160-520
Evap. HP variable-speed single-pump	116V	Single high-pressure water pump with variable speed drive (VSD), water filter, electronic water flow control, pressure transducers. Multiple possibilities of water flow control. For more details, refer to the dedicated chapter (expansion tank not included. Option with built-in hydraulic safety components available)	Easy and fast installation (plug & play), significant pumping energy cost savings (more than two-thirds), tighter water flow control, improved system reliability	30RQM/30RQP 160-520
HP VSD dual-pump hydronic mod.	116W	Dual high-pressure water pump with variable speed drive (VSD), pressure transducers. Multiple possibilities of water flow control. For more details, refer to the dedicated chapter (expansion tank not included. Option with built-in hydraulic safety components available)	Easy and fast installation (plug & play), significant pumping energy cost savings (more than two-thirds), tighter water flow control, improved system reliability	30RQM/30RQP 160-520
J-Bus gateway	148B	Two-directional communication board complying with JBus protocol	Connects the unit by communication bus to a building management system	30RQM/30RQP 160-520
Lon gateway	148D	Two-directional communication board complying with LonTalk protocol	Connects the unit by communication bus to a building management system	30RQM/30RQP 160-520
Bacnet over IP	149	Two-directional high-speed communication using BACnet protocol over Ethernet network (IP)	Easy and high-speed connection by ethernet line to a building management system. Allows access to multiple unit parameters	30RQM/30RQP 160-520
Energy Management Module	156	EMM Control board with additional inputs/outputs. See Energy Management Module option chapter	Extended remote control capabilities (Set-point reset, ice storage end, demand limits, boiler on/off command...)	30RQM/30RQP 160-520
Compliance with Russian regulations	199	EAC certification	Compliance with Russian regulations	30RQM/30RQP 160-520
Compliance with Australian regulations	200	Unit approved to Australian code	Compliance with Australian regulations	30RQM/30RQP 160-520
Power factor correction	231	Capacitors for automatic regulation of power factor (cos phi) value to 0.95.	Reduction of the apparent electrical power, compliance with minimum power factor limit set by utilities	30RQM/30RQP 160-520
Coil defrost resistance heaters	252	Electric heaters under the coils and the condensate pans	Prevents frost formation on the coils; compulsory in the heating mode, if the outdoor is below 0°C	30RQM/30RQP 160-520
Welded evaporator connection kit	266	Victaulic piping connections with welded joints	Easy installation	30RQM/30RQP 160-520
230 V electric plug	284	230 VAC power supply source provided with plug socket and transformer (180 VA, 0.8 A)	Permits connection of a laptop or an electrical device during unit commissioning or servicing	30RQM/30RQP 160-520
Expansion vessel	293	6-bar expansion tank integrated into the hydraulic module (option 116 required)	Easy and fast installation (plug & play), & Protection of closed water systems from excessive pressure	30RQM/30RQP 160-520
Screwed water connection sleeve kit for DSH	303	DSH connections with screw connection sleeves	Easy installation. Allows unit connection to a screw connector	30RQM/30RQP 160-520
Welded water connection kit for DSH	304	DSH inlet/outlet welded connection sleeves	Easy installation	30RQM/30RQP 160-520
Setpoint adjustment by 4-20 mA signal	311	Connections enabling a 4-20 mA signal input	Easy energy management, allow to adjust set point by a 4-20mA external signal	30RQM/30RQP 160-520

Brine Options (Option 6B)

Brine production from 0°C to -8°C is only possible with the low-temperature brine option 6B, available on sizes 30RQP 180-230-270-310 only.

The unit is equipped with insulation on the intake tubes. The insulation is reinforced on the low-temperature brine solution option.

The operating range depends on:

- the unit size,
- the glycol type,
- its concentration,
- the flow rate,
- the temperature of the glycol solution,
- the condensing pressure (ambient temperature).

Units with fans with available pressure for indoor installation (Option 12 - static high pressure fan)

This option applies to 30RQP 160-520 units installed inside the building in a plant room.

For this type of installation, the cold or hot air leaving the air heat exchangers is discharged by the fans to the outside of the building, using a duct system that causes a pressure drop in the air path.

Therefore, this option features more powerful fan motors than those fitted to standard units.

For each installation, the duct pressure drops differ, depending on the duct length, the duct section and the direction changes. 30RQP units with option 12 are designed to operate with air discharge ducts with maximum pressure drop of 200 Pa (units are equipped with variable-speed fans with a maximum speed of 19 r/s, instead of 15.8 r/s for standard units).

Use of variable speed up to 19 r/s can overcome the duct pressure drop while maintaining an optimized air flow per circuit. All fans in the same circuit, operating at the same time, have the same speed.

The fan power input for fans with a speed of 19 r/s is increased compared to that of standard fans with a speed of 15.8 r/s (the multiplier coefficient is the same as the cube of the speed ratio, i.e. x 1.72).

In the cooling / heating mode, the full-load or part-load speed is controlled by a patented algorithm that permanently optimizes the condensing / evaporating temperature to ensure the best unit energy efficiency (EER / COP) whatever the operating conditions and pressure drop of the system ductwork.

If necessary for a specific installation, the maximum fan speed of 30RQP unit can be fixed between 13.3 and 19 r/s, using the Service Configuration menu. Consult the 30RQM/RQP Touch Pilot Control manual for this modification.

The maximum configured speed applies to both the cooling and heating modes.

The performances (capacities, efficiencies) depend on the speed of the fans, then on the duct pressure drop:

- between 0 and 100 Pa, the unit performances are only slightly affected
- between 100 and 200 Pa, the unit performances may vary considerably, depending on the operating conditions (outdoor air temperature and water conditions)

The noise level into the ductwork and radiated around the unit is also related to the pressure drop.

Please refer to the Carrier Electronic catalogue to evaluate the impact of the estimated duct system on the 30RQP unit operating conditions.

Nominal and maximum air flows per circuit (A and B) for 30RQP sizes

30RQP	Circuit A Nominal/maximum air flow (l/s)	Circuit B Nominal/maximum air flow (l/s)
160	4514 / 5417	9028 / 10833
180-230	9028 / 10833	9028 / 10833
240-270	9028 / 10883	13542 / 16250
310-330	9028 / 10883	18056 / 21667
380	13542 / 16250	18056 / 21667
430-520	18056 / 21667	18056 / 21667

Principle of the installation of the ducts

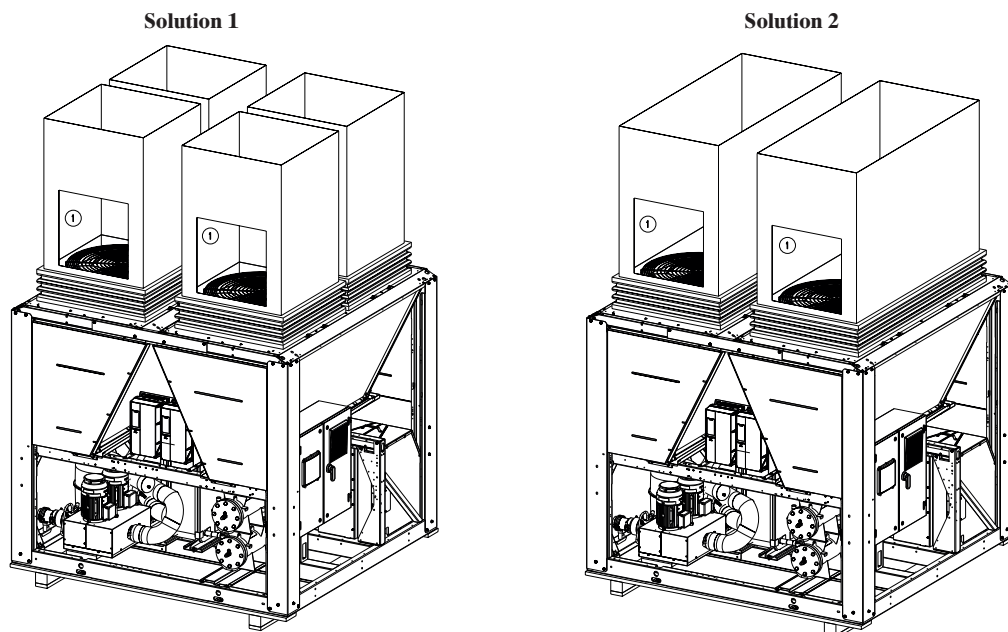

1. Fan motor access hatches (provide a 700 x 700 mm hatch) for each single and dual duct

Partial heat recovery using desuperheaters (option 49)

This option permits the production of free hot water using heat reclaim by desuperheating the compressor discharge gases. The option is available for the whole 30RQM/30RQP range. A plate heat exchanger is installed as standard, with the air heat

exchanger coils on the compressor discharge line of each circuit.

Physical data, 30RQM/30RQP units with partial heat reclaim

30RQM/30RQP		160	180	210	230	240	270	310	330	380	430	470	520
Desuperheater in circuits A/B		Plate heat exchanger											
Water volume circuit A/B		2/3.75	2/3.75	3.75/3.75	3.75/3.75	3.75/3.75	3.75/5.5	3.75/5.5	3.75/7.5	5.5/7.5	7.5/7.5	7.5/7.5	7.5/7.5
Max. water-side operating pressure		1000	1000	1000	1000	1000	1000	1000	1000	1000	1000	1000	1000
Refrigerant													
Circuit A charge ⁽⁴⁾	kg	16.0	22.2	23.7	25.5	29.2	29.2	32.8	36.8	46.2	55.2	56.7	59.2
	teqCO ₂	33.4	46.4	49.5	53.2	61.0	61.0	68.5	76.8	96.5	115.3	118.4	123.6
Circuit B charge ⁽⁴⁾	kg	23.7	23.7	23.7	25.5	37.1	38.5	49.7	55.2	55.2	55.2	56.7	59.2
	teqCO ₂	49.5	49.5	49.5	53.2	77.5	80.4	103.8	115.3	115.3	115.3	118.4	123.6
Water connections		Connection											
Connection	inch	2	2	2	2	2	2	2	2	2	2	2	2
External diameter	mm	60.3	60.3	60.3	60.3	60.3	60.3	60.3	60.3	60.3	60.3	60.3	60.3
30RQM													
Operating weight***													
Standard unit + desuperheater option	kg	1484	1553	1696	1719	2131	2289	2413	2648	3126	3380	3392	3433
Unit with options 15 and desuperheater	kg	1567	1636	1804	1827	2239	2415	2539	2792	3288	3561	3573	3613
Standard unit + option 15 + option 116S + option desuperheater	kg	1707	1776	1956	1978	2400	2624	2757	2997	3533	3806	3855	3894
30RQP													
Operating weight***													
Standard unit + desuperheater option	kg	1520	1589	1733	1755	2168	2326	2449	2685	3162	3438	3450	3499
Unit with options 15 and desuperheater	kg	1603	1672	1841	1863	2276	2452	2575	2829	3324	3618	3630	3679
Standard unit + option 15 + option 116S + option desuperheater	kg	1742	1812	1992	2015	2437	2660	2793	3034	3570	3863	3912	3960

*** Weights shown are a guideline only.

Performance available on ECAT Electronic catalogue

Hydronic module (option 116)

The new generation of Carrier hydronic module saves a lot of installation time. The heat pump is factory-equipped with the main components for the hydronic system: Water pump, electronic flow switch, Victaulic screen filter, pressure transducers, water temperature sensors, pressures taps (2), safety valve, drain valve, air vent, water purge, optional hydronic module heater and optional expansion tank.

The pressure transducers allow the control to:

- Display the available pressure at the unit outlet and the static system pressure
- Calculate the instantaneous flow rate, using an algorithm that integrates the unit characteristics
- Integrate the system and water pump protection devices (lack of water, water pressure, water flow rate, etc.).

On units fitted with Greenspeed variable-speed pump, the user display enables to:

- Adjust the required pump speed
- Adjust the required available pressure at the unit outlet and the static system pressure, to real customer needs thus saving energy: no need any more for a water flow control valve used for creating artificial pressure drops that are wasting energy.

Several water pump types are available to suit any application:

- Single or dual low-pressure pump or single or dual high-pressure pump
- Greenspeed variable-speed single or dual high-pressure pump.

If necessary, increased frost protection down to -20 °C is possible by adding the heater option to the hydronic module piping (see options 42A).

The hydronic module option is integrated into the heat pump without increasing its dimensions and saves the space normally used for the water pump.

Hydronic module

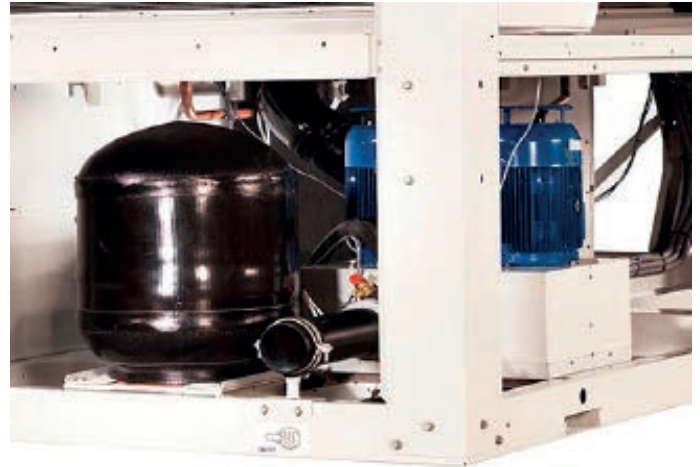

Key

Components of the unit and hydronic module:

1. Screen filter (mesh opening 1.2 mm)
2. Expansion tank (option)
3. Safety valve
4. Available pressure pump (single pump or dual pump)
5. Air purge
6. Water drain valve
7. Pressure sensor
Note: Gives pump suction pressure information
8. Temperature probe -
Note: Gives heat exchanger leaving temperature information
9. Temperature probe -
Note: Gives heat exchanger entering temperature information
10. Pressure sensor
Note: Gives unit leaving pressure information
11. Plate heat exchanger
12. Evaporator frost protection heater (option)

Installation components

14. Air purge
15. Flexible connection
16. Shut-off valve
17. Screen filter (obligatory for a unit without hydronic module)
18. Pressure gauge
19. Water flow control valve
Note: Not necessary for a hydronic module with a variable-speed pump
20. Charge valve
21. Frost protection bypass valve (when shut-off valves [16] are closed during winter)
23. Temperature probe well
- Hydronic module (unit with hydronic module)

Notes:

- The installation must be protected against frost.
- The hydronic module and unit evaporator are protected (option 42A, factory installed) against frost with electric heaters (item 12 + .
- The pressure sensors are installed at connections without Schraeder valves. Depressurise and drain the system before any intervention.

Typical hydronic circuit diagram

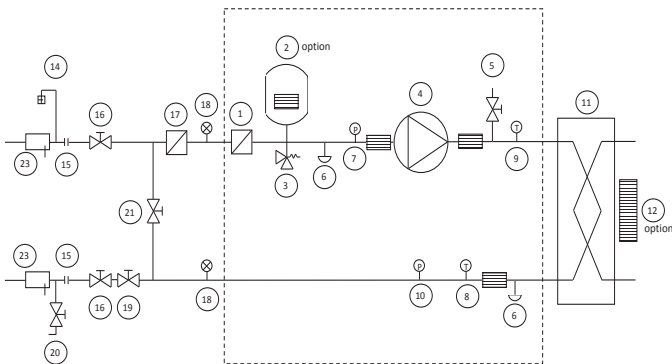

Electrical data, units with hydronic modules

The pumps that are factory installed in these units are eco-design compliant 2015 (EU regulation N°547/2012 for pumps) and have motors with efficiency class IE3. The additional electrical data required by regulation 640/2009 is given in the installation, operation and maintenance manual.

This regulation concerns the application of directive 2005/32/EC on the eco-design requirements for electric motors.

Variable Water Flow system (VWF) 30RQM/30RQP 160-520

Carrier Variable Water Flow

Recommended by Carrier, the Aquasnap can be equipped with one or two variable-speed pumps to save significant pumping energy costs (more than two-thirds), ensure tighter water flow rate control, and improve overall system reliability. Carrier Variable Water Flow (VWF) is a hydronic control



function package that controls the water flow rate. Carrier VWF not only ensures control at full load, a specific Carrier algorithm linked to an electronic frequency converter also continuously modulates the flow rate to minimise pump consumption at full load as well as part load. The Carrier hydronic module includes pressure transducers that permit intelligent measurement of the water flow rate and real-time display on the or Touch Pilot user interface. All adjustments can be made directly on the interface, speeding up start-up and maintenance. As Carrier VWF acts directly on the pump, the system no longer requires the control valve at the unit outlet. However, for applications with two-way valves a bypass system must be kept to guarantee the minimum flow rate.

Operating principle

- Full-load set point
The flow rate at full load is controlled by the interface, which reduces the pump speed. This first control saves energy that would normally be dissipated in the control valve. For example, if the pressure supplied by the pump is reduced by 20%, the energy consumption of the pump is reduced by the same ratio, compared to a conventional installation.



- Operating mode at part load
Touch Pilot includes three part-load operating modes:
 - Fixed speed control
 - Constant delta P control
 - Constant delta T control.

1 - Fixed speed

The control continuously ensures a constant pump speed based on compressor capacity.

When the compressor capacity is equal to zero, the pump speed can be automatically reduced to a second set-point (adjustable down to 60%) to save energy during low occupancy periods.

This solution is suitable for traditional installations with constant water flow and terminal units equipped with three-way valves. This solution reduces pumping energy costs especially when the flow can be reduced during night-time periods.

2 - Constant delta P control

The control continuously acts on the pump speed to ensure a constant delta P.

This solution is suitable for installations with two-way valves. When these close, the water speed will accelerate in the system branches that are still open. For a fixed-speed pump this results in an unnecessary increase of the pressure at the pump outlet.

The constant delta P control mode ensures that each circuit branch always has a uniform supply, without unnecessary energy waste.

In industrial processes such as plastic injection moulding, this solution ensures that each terminal unit has the correct pressure supply.

3 - Constant delta T control

The VWF algorithm maintains a constant delta T no matter what the unit load, reducing the flow rate to the minimum. It is suitable for the majority of comfort applications.

Electrical data

30RQM		160	180	210	230	240	270	310	330	380	430	470	520
Power circuit													
Nominal power supply	V-ph-Hz	400 - 3 -50											
Voltage range	V	360 - 440											
Control circuit supply		24 V via internal transformer											
Nominal unit current draw ⁽¹⁾													
Circuit A&B	A	100	110	133	147	151	166	191	199	233	266	294	322
Maximum unit power input ⁽²⁾													
Circuit A&B	kW	80	88	107	118	120	134	152	161	188	215	236	258
Cosine Phi unit at maximum power ⁽²⁾		0,88	0,87	0,88	0,88	0,87	0,88	0,87	0,88	0,88	0,88	0,88	0,88
Maximum unit current draw (Un-10%) ⁽³⁾													
Circuit A&B	A	144	158	192	211	215	241	273	289	337	385	422	460
Maximum unit current draw (Un) ⁽⁴⁾													
Circuit A&B - Standard Unit	A	133	146	177	195	199	222	252	266	310	354	390	425
Circuit A&B - Unit with option 231	A	100	110	133	148	151	166	192	200	233	266	296	326
Maximum start-up current, standard unit (Un) ⁽⁵⁾													
Circuit A&B	A	307	356	352	406	409	396	462	440	485	529	600	636
Max. start-up current, unit with soft starter (Un) ⁽⁵⁾													
Circuit A&B	A	261	283	305	332	336	350	389	394	438	482	527	562

⁽¹⁾ Conditions equivalent to the standardised Eurovent conditions (evaporator water input-output temperature = 12 °C/7 °C, outside air temperature = 35 °C)

⁽²⁾ Power input, compressors and fans, at the unit operating limits (saturated suction temperature 15 °C, saturated condensing temperature 68.3 °C) and nominal voltage of 400 V (data given on the unit nameplate).

⁽³⁾ Maximum unit operating current at maximum unit power input and at 360 V.

⁽⁴⁾ Maximum unit operating current at maximum unit power input and at 400 V (values given on the unit nameplate).

⁽⁵⁾ Maximum instantaneous starting current at operating limits (maximum operating current of the smallest compressor(s) + current of the fan(s) + locked rotor current of the largest compressor). Fan motor electrical data reported upstream the variable speed drive at Eurovent equivalent conditions and motor ambient air temperature of 50 °C at 400 V: Current 3.8 A; Start-up current 20 A; Power input: 1.75 kW.

30RQP		160	180	210	230	240	270	310	330	380	430	470	520
Power circuit													
Nominal power supply	V-ph-Hz	400 - 3 -50											
Voltage range	V	360 - 440											
Control circuit supply		24 V via internal transformer											
Nominal unit current draw ⁽¹⁾													
Circuit A&B	A	97	107	130	144	147	162	186	195	227	260	288	316
Maximum unit power input ⁽²⁾													
Circuit A&B	kW	81	88	108	118	120	134	153	161	188	215	237	259
Cosine Phi unit at maximum power ⁽²⁾		0,88	0,88	0,88	0,88	0,88	0,88	0,88	0,88	0,88	0,88	0,88	0,88
Maximum unit current draw (Un-10%) ⁽³⁾													
Circuit A&B	A	142	154	189	208	211	237	268	284	331	378	416	454
Maximum unit current draw (Un) ⁽⁴⁾													
Circuit A&B - Standard Unit	A	131	142	174	192	195	218	247	261	305	348	383	419
Circuit A&B - Unit with option 231	A	98	108	131	146	148	164	188	197	230	262	291	321
Maximum start-up current, standard unit (Un) ⁽⁵⁾													
Circuit A&B	A	305	353	349	402	405	392	458	436	479	523	594	629
Max. start-up current, unit with soft starter (Un) ⁽⁵⁾													
Circuit A&B	A	259	279	302	329	332	346	384	389	433	476	520	556

⁽¹⁾ Conditions equivalent to the standardised Eurovent conditions (evaporator water input-output temperature = 12 °C/7 °C, outside air temperature = 35 °C)

⁽²⁾ Power input, compressors and fans, at the unit operating limits (saturated suction temperature 15 °C, saturated condensing temperature 68.3 °C) and nominal voltage of 400 V (data given on the unit nameplate).

⁽³⁾ Maximum unit operating current at maximum unit power input and at 360 V.

⁽⁴⁾ Maximum unit operating current at maximum unit power input and at 400 V (values given on the unit nameplate).

⁽⁵⁾ Maximum instantaneous starting current at operating limits (maximum operating current of the smallest compressor(s) + current of the fan(s) + locked rotor current of the largest compressor). Fan motor electrical data reported upstream the variable speed drive at Eurovent equivalent conditions and motor ambient air temperature of 50 °C at 400 V: Current 3.8 A; Start-up current 20 A; Power input: 1.75 kW.

Short-circuit stability current (TN system)*

30RQM/30RQP		160	180	210	230	240	270	310	330	380	430	470	520
Short-time assigned current I_{cs} (1s) rms value/peak I_{pk}⁽¹⁾													
Circuits A & B	kA/kA	8/30	8/30	8/30	8/30	8/30	8/30	15/65	15/65	15/65	15/65	20/80	20/80
With fuses upstream - maximum fuse values assigned (gL/gG)													
Circuits A & B	A	200	200	200	250	250	250	315	315	400	400	630	630
With fuses upstream – assigned conditional short-circuit current I_{cc}/I_{cf}													
Circuits A & B	kA	50	50	50	50	50	50	50	50	50	50	50	50

* Type of system earthing

IT system: The short circuit current stability values given above for the TN system are not valid for IT, modifications are required.

Electrical data notes for 30RQM/30RQP units:

- 30RQM/30RQP units have a single power connection point located immediately upstream of the main switch.
- **Control box includes:**
 - Main disconnect switch,
 - Start-up and motor protection devices for each compressor, fans and pumps,
 - Control devices.
- **Field connections:**

All connections to the system and the electrical installations must be in accordance with all applicable codes.
- The Carrier 30RQM/30RQP units are designed and built to ensure conformance with these codes. The recommendations of European standard EN 60204-1 (corresponds to IEC 60204-1) (machine safety - electrical machine components - part 1: General regulations) are specifically taken into account, when designing the electrical equipment.

Notes

- Generally the recommendations of IEC 60364 are accepted as compliance with the requirements of the installation regulation.
- Conformance with EN 60204-1 is the best means of ensuring compliance (§1.5.1) with the Machinery Directive.

Appendix B of standard EN 60204-1 specifies the electrical features used for the operation of the machines.
- The operating conditions of 30RQM/30RQP units are described below:
 1. Physical environment*

The classification of environment is specified in standard EN 60364:

 - Outdoor installation*,
 - Ambient temperature range: Minimum temperature -20 °C up to +48 °C**,
 - Altitude: AC1 Lower than or equal to 2000 m (for the hydronic module, see paragraph 4.7 in the IOM),
 - Presence of hard solid: Class AE3 (no significant dust present)*,
 - Presence of corrosive and polluting substances, class AF1 (negligible),
 - Competence of personnel: BA4 (informed personnel).
 2. Compatibility for low-frequency conducted disturbances according to class 2 levels per IEC61000-2-4 standard:
 - Power supply frequency variation : +2Hz
 - Phase imbalance : 2%
 - Total Voltage Harmonic Distortion (THDV) : 8%
 3. The neutral (N) line must not be connected directly to the unit (if necessary use a transformer).
 4. Overcurrent protection of the power supply conductors is not provided with the unit.
 5. The factory-installed disconnect switch(es)/circuit breaker(s) are of a type suitable for power interruption in accordance with EN 60947-3 (corresponds to IEC 60947-3).

6. The units are designed for connection to TN networks (IEC 60364). In IT networks the use of noise filters integrated into the variable frequency drive(s) make machine use unsuitable. In addition, the equipment characteristics in case of insulation failure are modified. Provide a local earth; contact competent local organisations to have the electrical installation completed.

30RQM/30RQP models are designed for use in domestic/residential and industrial environments:
those not equipped with variable frequency drive(s) comply with the standards below.

- 61000-6-3: Generic standard - Emission standard for residential, commercial and light-industrial environments,

- 61000-6-2: Generic standard - Immunity for industrial environments.

Machines that are equipped with variable frequency drive(s) (RQP, options: 28, 116V, 116W) comply with standard EN61800 - 3 "Adjustable speed electrical power drive systems - Part 3: EMC requirements and specific test methods" for the following classifications:

- Use in the first and second environments***.

- Category C2 applicable in the first environment to stationary devices designed to be installed and commissioned by a professional only.

Warning: In a residential environment, this product may cause radio interference in which case additional mitigation measures could be required.

- Leakage currents: If protection by monitoring the leakage currents is necessary to ensure the safety of the installation, the presence of additional leakage currents introduced by the use of variable frequency drive(s) in the unit must be considered. In particular these protection devices shall be of reinforced immunity types and have a threshold not lower than 150 mA.
- Capacitors that are integrated as part of the option 231 can generate electrical disturbances in the installation the unit is connected to. Presence of these capacitors must be considered during the electrical study prior to the start-up.

Note: If particular aspects of an actual installation do not conform to the conditions described above, or if there are other conditions which should be considered, always contact your local Carrier representative.

* The required protection level for this class is IP43BW (according to reference document IEC 60529). All 30RQM/30RQP units are IP44CW and fulfil this protection condition.

** The maximum ambient temperature allowed for machines equipped with option 231 is +40°C

** - Example of installations included in the first environment: commercial and residential buildings.

- Example of installations included in the second environment: industrial zones, technical locations supplied from a dedicated transformer.

Operating limits

Heat exchanger water flow rate

30RQM/30RQP 160-520 without hydronic module		
	Minimum flow rate (l/s)*	Maximum flow rate (l/s)**
160	2.9	17.5
180	3.1	17.5
210	3.8	17.5
230	4.1	21.8
240	4.2	29.8
270	4.8	29.8
310	5.5	35.2
330	5.8	40.4
380	6.7	40.4
430	7.8	40.4
470	8.4	41.6
520	9.2	43.4

* Minimum flow rate for the conditions of permissible maximum water delta (10K) to the value of minimum leaving water temperature (5 °C)

** The maximum flow rate corresponds to a pressure drop of 100 kPa in the heat exchanger plate

30RQM/30RQP 160-520 with low pressure hydronic module			
	Minimum flow rate (l/s)*	Maximum flow rate (l/s)	
		Single	Dual
160	2.9	12.2	10.3
180	3.1	12.2	12.2
210	3.8	14.3	14.0
230	4.1	14.3	14.0
240	4.2	20.3	18.0
270	4.8	20.3	18.0
310	5.5	20.3	18.5
330	5.8	25.0	25.0
380	6.7	25.0	25.0
430	7.8	25.0	25.0
470	8.4	28.6	26.6
520	9.2	28.6	28.6

* Minimum flow rate for the conditions of permissible maximum water delta (10K) to the value of minimum leaving water temperature (5 °C)

30RQM/30RQP 160-520 with high pressure hydronic module			
	Minimum flow rate (l/s)*	Maximum flow rate (l/s)	
		Single	Dual
160	2.9	14.1	11.7
180	3.1	14.1	11.7
210	3.8	16.1	16.1
230	4.1	16.1	16.1
240	4.2	16.1	16.1
270	4.8	26.6	26.5
310	5.5	26.6	26.5
330	5.8	26.6	26.5
380	6.7	26.6	29.2
430	7.8	26.7	29.2
470	8.4	26.7	35.0
520	9.2	35.0	35.0

* Minimum flow rate for the conditions of permissible maximum water delta (10K) to the value of minimum leaving water temperature (5 °C)

Unit operating limits

Units 30RQM/RQP 160-520 Cooling Mode			
Water heat exchanger		Minimum	Maximum
Water inlet temperature at start-up	°C	8(1)	40
Water outlet temperature during operation	°C	5(2)	20(3)
Water outlet temperature during operation Low-temperature brine option	°C	-8(8)	20(3)
Air heat exchanger			
Ambient operating temperature - 30RQM	°C	0(4)(6)	48(7)
Ambient operating temperature - 30RQM option 28 or 30RQP	°C	-20(4)(6)	48(7)
Available static pressure			
Standard unit (outdoor installation)	Pa	0	0

Units 30RQM/RQP 160-520 Heating Mode			
Water heat exchanger		Minimum	Maximum
Water inlet temperature at start-up	°C	8(1)	50
Water outlet temperature during operation	°C	20	55
Air heat exchanger			
Outdoor ambient operating temperature	°C	-10(5)(6)	35
Available static pressure			
Standard unit (for outdoor installation)	Pa	0	0

- (1) For an application requiring operation at less than 8°C, contact Carrier to select a unit from the Carrier electronic catalogue.
- (2) Use of antifreeze protection is required if the leaving water temperature is below 5 °C.
- (3) For applications requiring operation with a water outlet temperature above 20°C, contact Carrier to select a unit from the Carrier electronic catalogue.
- (4) For operation from 0°C down to -20°C (cooling mode), heat pump must be a 30RQM unit equipped with option 28 "Winter operation" or must be a 30RQP unit.
- (5) For operation from 0°C down to -10°C (heating mode), heat pump shall be equipped with option 252 "Coil defrost resistance heaters".
- (6) For any operation below 0°C (cooling mode and heating mode), the heat pump must be equipped with option 41 "Water exchanger frost protection" (unit without hydronic module) or with option 42A "Water exchanger and hydronic module frost protection" (unit with hydronic module) or the water circuit must be protected against frost using an anti-freeze solution.
- (7) The maximum ambient temperature allowed for machines equipped with option 231 is +40°C.
- (8) Operation with low temperature brine for 30RQP 180/230/270/310 only

Maximum ambient temperature: in case of 30RQM/30RQP units storage and transport, minimum and maximum ambient temperatures to respect are -20°C and +52°C. These temperature limits shall be considered in case of container shipment.

Operating range for 30RQM/RQP 160-520 cooling mode

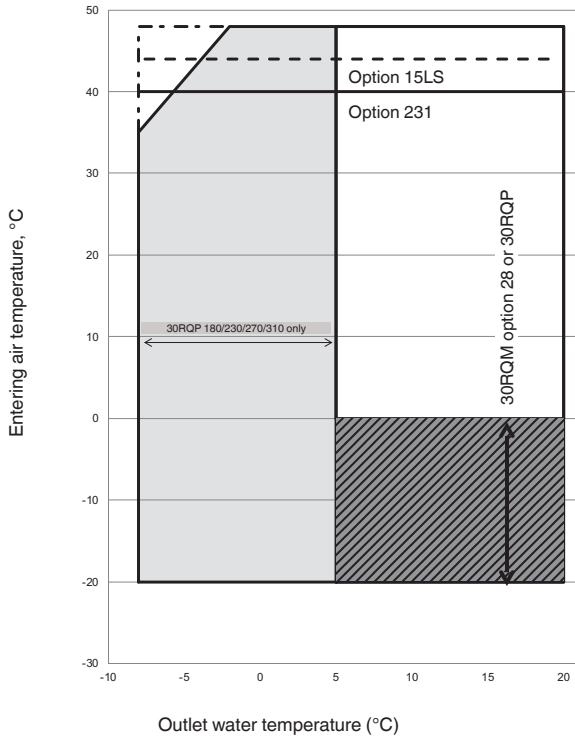



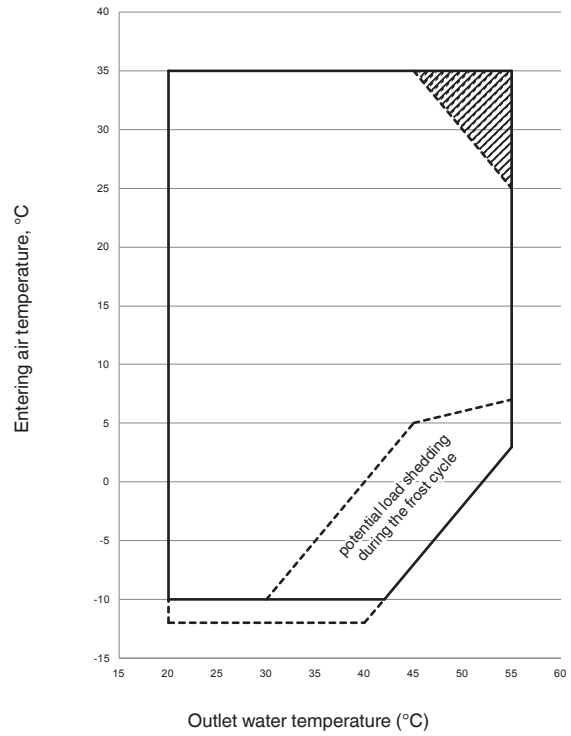



Operating range for 30RQM/RQP 160-520 heating mode



Notes

- 1 Evaporator $\Delta T = 3K$
- 2 The unit must be equipped with the water heat exchanger frost protection option (for units without hydronic module option) or the water heat exchanger and hydronic module frost protection option (for units with hydronic module option) or the water loop must be protected against frost using an anti-freeze solution for outdoor air temperatures below 0°C
- 3 Operating ranges are guidelines only. The operating range must be checked with the selection software

Key

-  Operating range at full load, 30RQM unit or 30RQP unit
-  Extended operating range in cooling mode: 30RQM unit, option 28 "Winter operation" down to outside temperatures of -20°C or 30RQP unit. The water heat exchanger must be protected against frost (see note 2).
-  Operating range at part load for 30RQM/30RQP 310 unit. Other sizes operate at full load.
-  Potential load shedding during the frost cycle depending on the humidity conditions. Refer to the manufacturer's electronic catalogue.
-  Low temperature brine solution option
-  Partial load for low temperature brine solution option

Available static system pressure

Data applicable for:

- Fresh water 20 °C
- Refer to the paragraph "Heat exchanger water flow rate" for maximum water flow values.
- In case of use of the glycol, the maximum water flow rate is reduced.

Units 30RQM/30RQP high-pressure pumps (fixed speed or variable speed at 50Hz)

Single pumps

Sizes 160-240

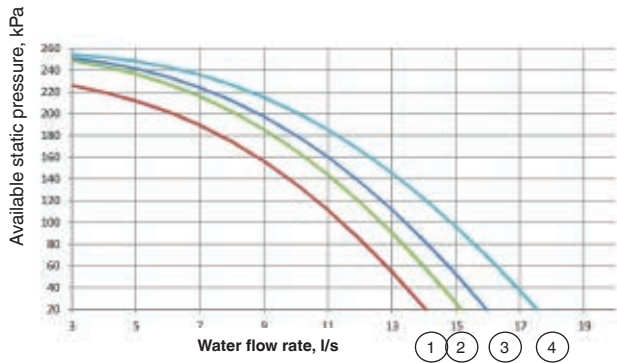

- 1 30RQM/30RQP 160-180
- 2 30RQM/30RQP 210
- 3 30RQM/30RQP 230
- 4 30RQM/30RQP 240

Sizes 270-520

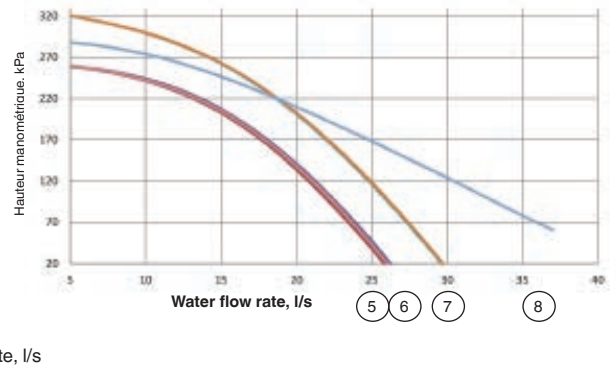

- 5 30RQM/30RQP 270-310
- 6 30RQM/30RQP 330-380
- 7 30RQM/30RQP 430-470
- 8 30RQM/30RQP 520

Dual pumps

Sizes 160-240

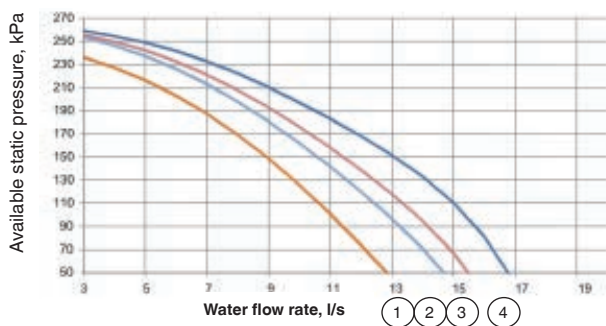

- 1 30RQM/30RQP 160-180
- 2 30RQM/30RQP 210
- 3 30RQM/30RQP 230
- 4 30RQM/30RQP 240

Sizes 270-520

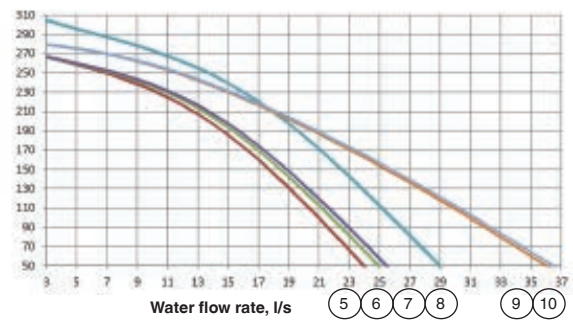

- 5 30RQM/30RQP 270
- 6 30RQM/30RQP 310
- 7 30RQM/30RQP 330
- 8 30RQM/30RQP 380-430
- 9 30RQM/30RQP 470
- 10 30RQM/30RQP 520

Available static system pressure

Data applicable for:

- Fresh water 20 °C
- Refer to the paragraph "Heat exchanger water flow rate" for maximum water flow values.
- In case of use of the glycol, the maximum water flow rate is reduced.

Units 30RQM/30RQP low-pressure pumps (fixed speed)

Single pumps

Sizes 160-270

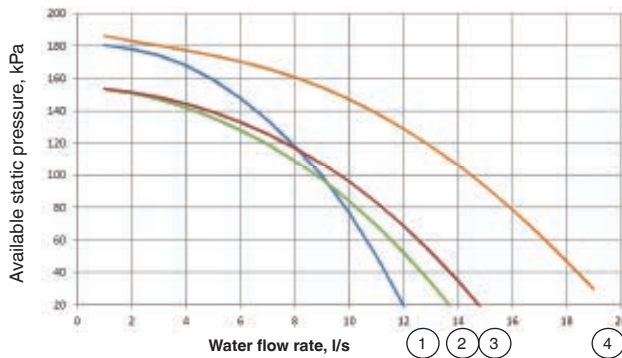

- 1 30RQM/30RQP 160-180
- 2 30RQM/30RQP 210
- 3 30RQM/30RQP 230
- 4 30RQM/30RQP 240-270

Sizes 310-520

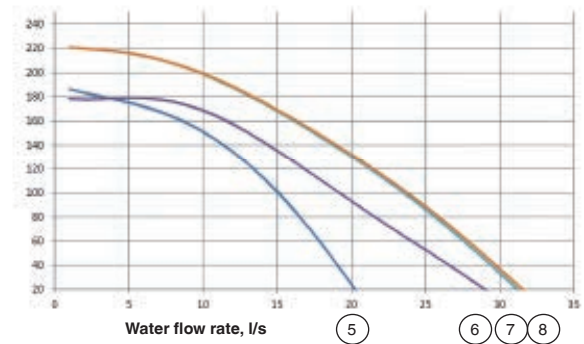

- 5 30RQM/30RQP 310
- 6 30RQM/30RQP 330-380-430
- 7 30RQM/30RQP 470
- 8 30RQM/30RQP 520

Water flow rate, l/s

Dual pumps

Sizes 160-230

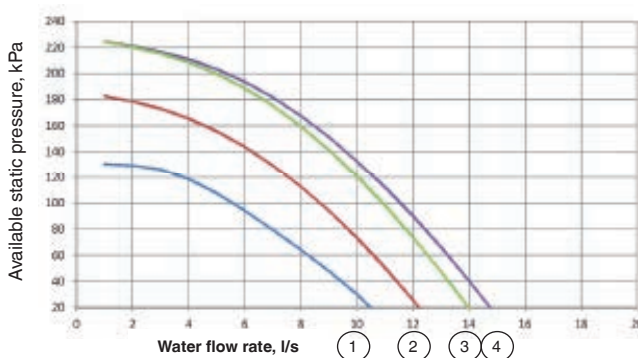

- 1 30RQM/30RQP 160
- 2 30RQM/30RQP 180
- 3 30RQM/30RQP 210
- 4 30RQM/30RQP 230

Sizes 240-520

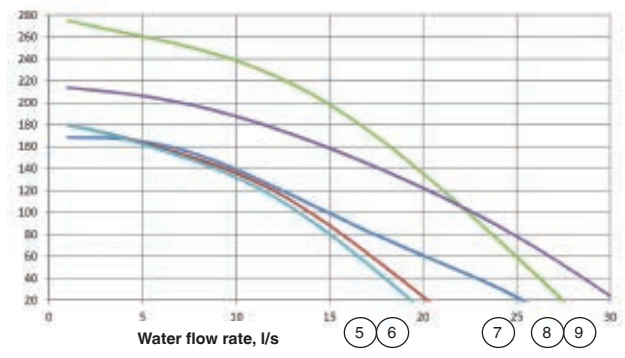

- 5 30RQM/30RQP 240-270
- 6 30RQM/30RQP 310
- 7 30RQM/30RQP 330-380-430
- 8 30RQM/30RQP 470
- 9 30RQM/30RQP 520

Water flow rate, l/s

Dimensions/clearances

30RQM/30RQP 160-230 (with and without hydronic module)

Unit without hydronic module

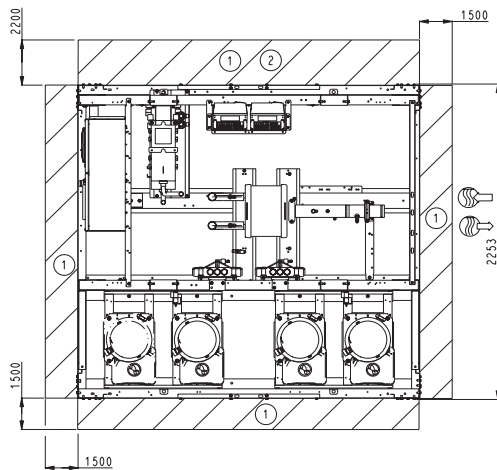
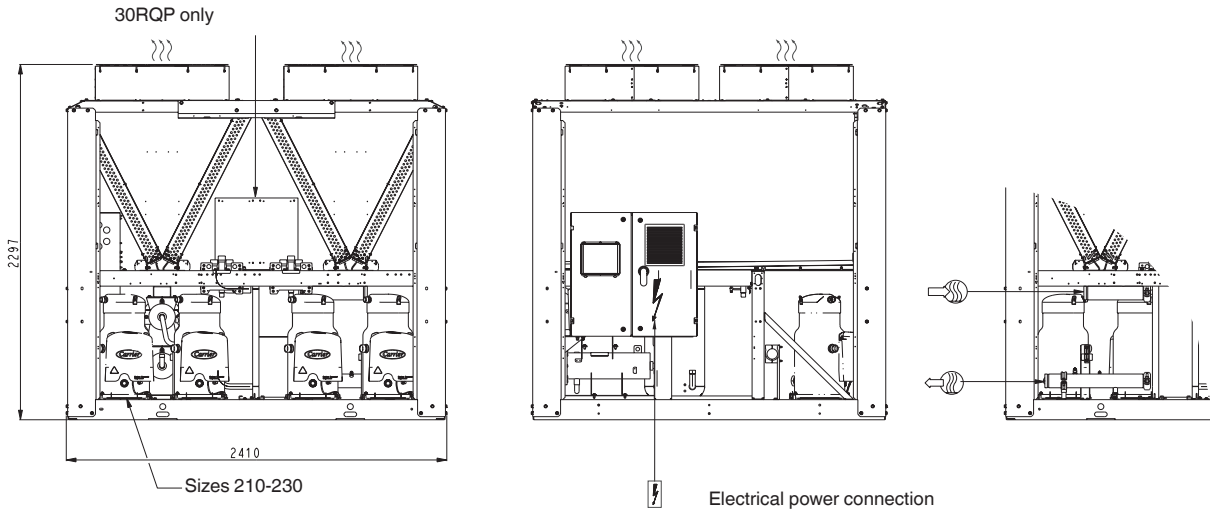

Key:

All dimensions are in mm.

- 1 Clearances required for maintenance and air flow
- 2 Clearances recommended for removal of the coils
- Water inlet
- Water outlet
- Air outlet, do not obstruct
- Control box

Note: Drawings are not contractually binding. Before designing an installation, consult the certified dimensional drawings, available on request.

Unit with hydronic module

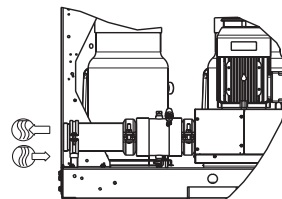
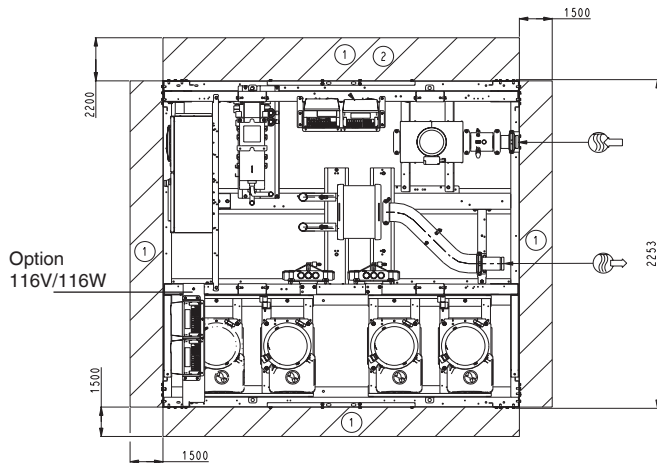

For the positioning of the fixing points, weight distribution points and centre of gravity coordinates please refer to the dimensional drawings.

Dimensions/clearances

30RQM/30RQP 240-330 (with and without hydronic module)

Unit without hydronic module

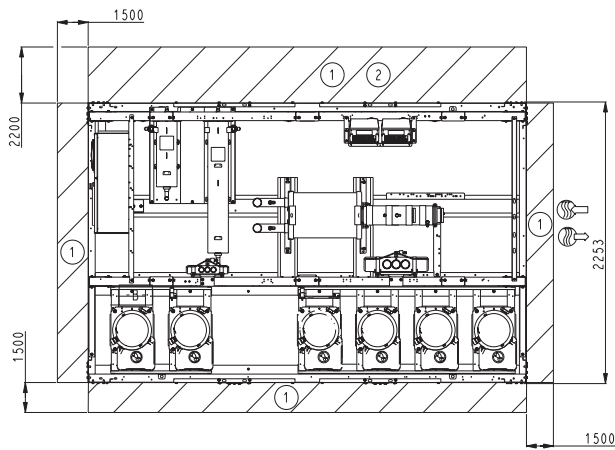
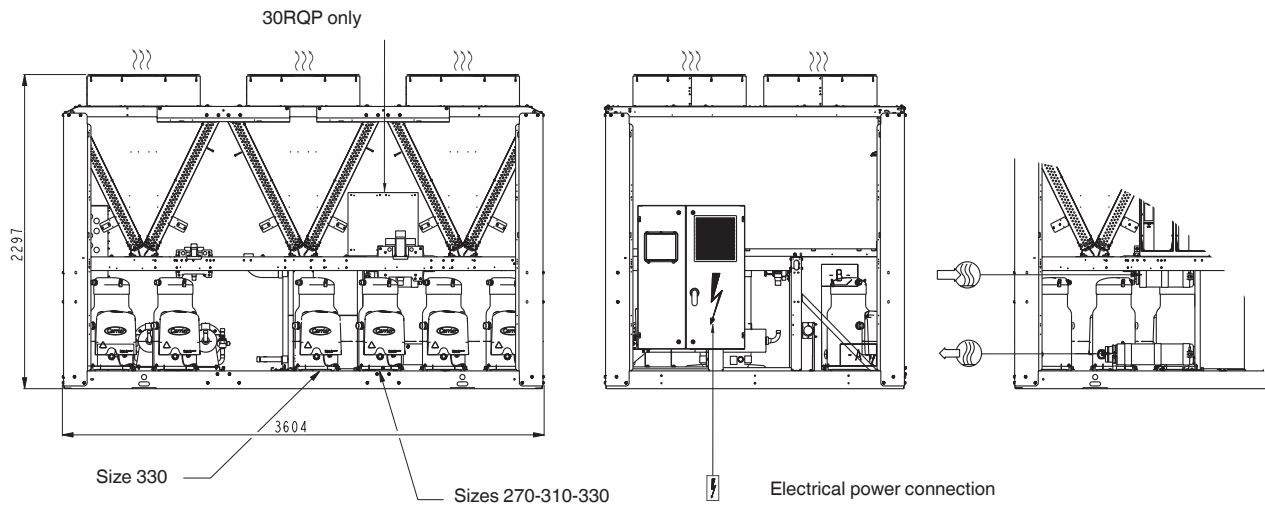

Key:

All dimensions are in mm.

- ① Clearances required for maintenance and air flow
- ② Clearances recommended for removal of the coils
- Water inlet
- Water outlet
- Air outlet, do not obstruct
- Control box

Note: Drawings are not contractually binding. Before designing an installation, consult the certified dimensional drawings, available on request.

Unit with hydronic module

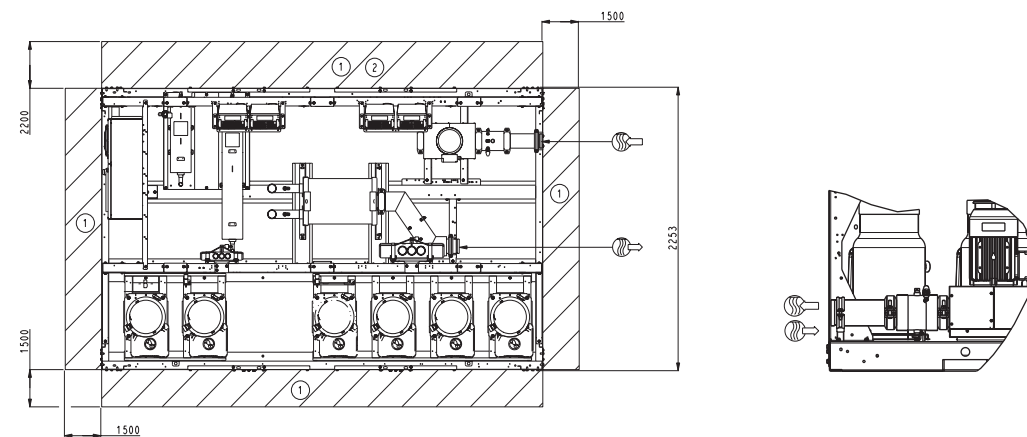

For the positioning of the fixing points, weight distribution points and centre of gravity coordinates please refer to the dimensional drawings.

Dimensions/clearances

30RQM/30RQP 380-520 (with and without hydronic module)

Unit without hydronic module

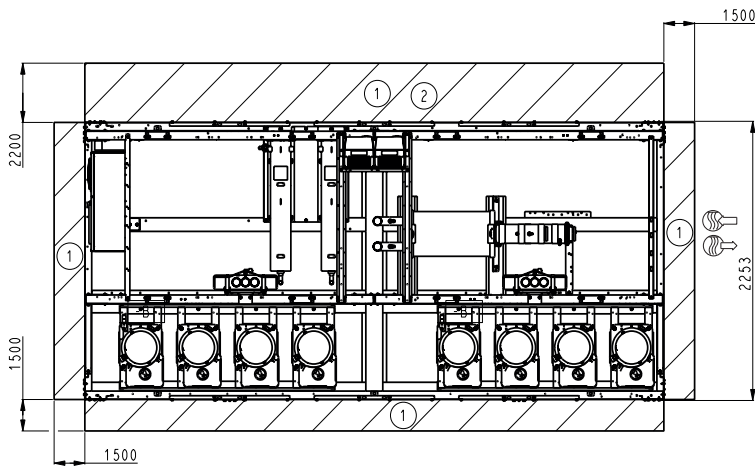
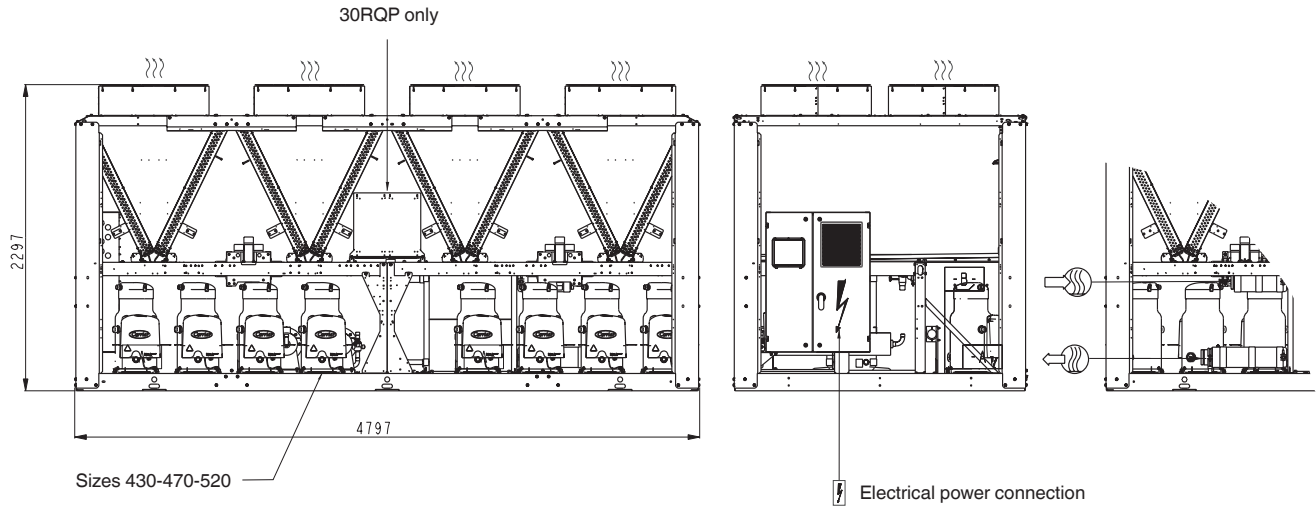

Key:

All dimensions are in mm.

- ① Clearances required for maintenance and air flow
- ② Clearances recommended for removal of the coils
- Water inlet
- Water outlet
- Air outlet, do not obstruct
- Control box

Note: Drawings are not contractually binding. Before designing an installation, consult the certified dimensional drawings, available on request.

Unit with hydronic module

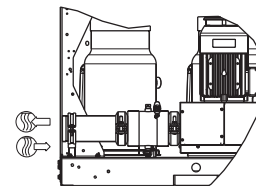
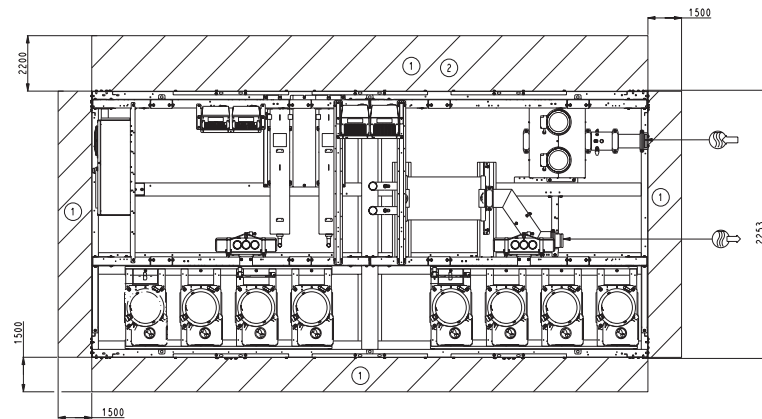

For the positioning of the fixing points, weight distribution points and centre of gravity coordinates please refer to the dimensional drawings.

Specification guide - 30RQP

System description

Factory assembled, air-to-water heat pump utilising scroll compressors, low sound **Greenspeed® variable-speed fans** and optional hydronic pump module. The unit shall include all necessary wiring, piping, charge of R410A refrigerant, microprocessor controls and user display.

Note: Hydronic pump module shall be available with fixed-speed or Greenspeed® variable-speed driven pump(s).

Quality assurance

Unit shall be rated in accordance with EN14511-3 Standard, latest revision and unit performances shall be **certified by independent Eurovent certification body**. Unit without independent Eurovent certification shall be excluded.

Unit construction shall comply with European directives:

- Commission Regulation (EU) N° 813/2013 implementing Directive 2009/125/EC of the European Parliament and of the Council with regard to Eco-design requirements for space heaters and combination heaters
- Commission regulation (EU) No.327/2011 implementing Directive 2009/125/EC with regards to Eco-design requirements for industrial fans.
- Commission regulation (EU) No.640/2009 implementing Directive 2009/125/EC with regards to Eco-design requirements for electric motors.
- From 1st January 2015, commission regulation (EU) No. 547/2012 implementing Directive 2009/125/EC with regards to Eco-design requirements for water pumps (unit equipped with hydronic module option).
- Pressurised equipment directive (PED) 2014/68/EU
- Machinery directive 2006/42/EC, modified
- Low voltage directive 2014/35/EU, modified
- Electromagnetic compatibility directive 2014/30/EU, modified, and the applicable recommendations from European standards
- Machine safety: Electrical equipment in machines, general requirements, EN 60204-1
- Electromagnetic emission and immunity EN 61800-3 'C3'

Unit shall be manufactured in a facility registered to ISO 9001 Manufacturing Quality Standard and to ISO 14001 Environmental Management System. Unit shall be tested at the factory.

Design performance data

Performance data certified by Eurovent independent body (mandatory).

- Cooling capacity (kW):
- Heating capacity (kW):
- Part load energy efficiency in cooling, ESEER:
- Full load energy efficiency in cooling, EER following EN14511:3 2013 (kW/kW):
- Part load energy efficiency in heating, SCOP following EN14825 (kW/kW):
- Full load energy efficiency in heating, COP following EN14511:3 2013 (kW/kW):
- Entering/leaving water temperature (°C): /
- Hot entering/leaving water temperature (°C): /
- Fluid type:
- Fluid flow rate (l/s):
- Water heat exchanger pressure drops (kPa):

- Outdoor air temperature (°C):
- Sound power level at full load (dB(A)):
- Sound power level during night* (dB(A)):
- Refrigerant type: (ODP ... / GWP)
- Refrigerant charge: kg (.... kg/kW), teqCO₂,....
- Dimensions, length x depth x height (mm): /
- Unit operating weight:

* Night sound power level is given for unit demand limit 50% capacity and 25 °C outside ambient temperature.

Unit construction

- Frame shall be of heavy-gage, painted galvanised steel.
- Electrical Cabinet shall be galvanised steel casing painted in oven-baked polyester powder paint (light grey, RAL7035).

Compressor assembly

- Fully hermetic scroll type compressors, each equipped with:
- Two-pole electric motor (Direct on line 400 V, 2900 rpm at 50 Hz) cooled by suction gas and protected by internal temperature sensors.
 - Initial oil charge of synthetic polyolester oil
 - Integral oil level sight glass
 - Electric crankcase heater to minimise oil dilution and refrigerant migration
 - Electronic over temperature motor protection
 - Optional soft starter to minimise compressor starting current with phase loss protection.

Low noise level and low vibration level shall be guaranteed by:

- Flexible anti-vibration mounts to isolate compressor assembly from unit chassis
- Suction and discharge piping designed to prevent the transmission of vibrations to the unit chassis
- Optional acoustic compressor enclosure, easily removable with 1/4 turn fasteners.

Water heat exchanger

- Asymmetric brazed plate heat exchanger, direct expansion
- Design shall incorporate a minimum of two independent direct-expansion refrigerant circuits.
- The plate heat exchangers shall be made of AISI 316L stainless steel, with brazed copper welding.
- The exchangers shall be thermally insulated with 19-mm closed cell foam insulation with a maximum K factor of 0.28.
- These shall be equipped with Victaulic-type fluid connections.
- Water heat exchanger shall be tested and stamped in accordance with European PED 97/23/EC Code.
- Water heat exchanger pressure drop shall not exceed 45 kPa under Eurovent conditions. Water heat exchanger with higher pressure drops shall be excluded.
- Water heat exchanger shall be provided with a factory-installed electronic flow switch.

Air heat exchanger

- coil shall be air-cooled copper tube aluminium fins heat exchanger (Cu/Al).
- Coil design shall adopt a V-shape for coil protection against hail damage. Vertical coils shall be excluded.
- Assembled condenser coils shall be 100% leak tested and pressure tested at 45 bars.

Fans

- All fans on the unit shall have variable speed drive (with Greenspeed® intelligence) to provide higher part load efficiency and reduced acoustic levels.
- In Cooling mode fans shall be automatically controlled (Greenspeed® intelligence) to achieve higher part load efficiency, winter operation down to -20 °C outside air temperature as standard, automatic fan speed adjustment in case of coil fouling, floating condensing pressure, smooth fan start to increase unit lifetime and eliminate start/stop noise for sensitive acoustic applications.
- In Heating mode, all fans shall be automatically controlled (Greenspeed® intelligence) to achieve higher part load efficiency, fan speed adjustment in case of coil fouling or freezing, floating evaporator pressure, smooth fan start to increase unit lifetime and eliminate start/stop noise for sensitive acoustic applications.
- Each refrigerant circuit shall have a factory-installed, independent variable speed drive. Variable speed drives shall be rated IP 55 enclosures and CE compliant.
- Air heat exchanger fans shall have a minimum overall efficiency higher than the minimum efficiency target to comply with commission regulation (EU) N°327/2011 implementing Directive 2009/125/EC with regards to Eco-design requirements for industrial fans.
- These must have direct drive, and be equipped with a 9-blade impeller with an aerodynamic profile and a rotating rim to ensure optimum sealing between the fan blades and scroll. The fan rotors must have a non-modular construction, and be made from a corrosion-resistant composite material. They must be well-balanced, both statically and dynamically.
- Air shall be discharged vertically upward.
- The fans shall be protected by polyethylene-coated steel wire safety guards.
- Winter operation down to -20 °C outside air temperature as standard in cooling mode.

Refrigerant

- HFC R410-A refrigerant

Refrigerant circuit components

Refrigerant circuit components shall include:

- Replaceable-core filter drier
- Moisture indicating sight glass
- Electronic expansion device
- Liquid line service valves
- Complete operating charge of refrigerant R-410A and compressor oil.

Electrical data

- Unit shall operate on 400 V, 3-phase, 50 Hz +/-10% power supply without neutral.
- Control voltage shall be supplied by a factory-installed transformer.
- Unit shall be supplied with factory-installed main circuit breaker, also acting as electrical disconnect/isolator.

Touch Pilot Control

The Touch Pilot Control shall include advanced communication technology over Ethernet (IP), and a user-friendly, intuitive user interface with a 5-inch colour touch screen.

Advanced controls features

- Web connectivity.
- Fast BACnet IP connectivity (with "BACnet® IP Communication" option)
- Alarm notification via email.
- Track trending values (Web Browser display only).
- Downloadable documentation (unit installation manual, control manual, spare-part list)

Touch Pilot, 5" user interface

- Modern and intuitive 5-inch colour screen
- Finger or pencil touch capable
- All local interaction accessible (Quick test, Start/Stop, Operating mode, etc.)
- Trending display
- Synoptic screen with current operating status and physical values
- Eight unicode languages supported including Chinese
- Possibility to load a custom translation file
- Access to the interface through Web Browser.

Controls features

- Automatic management of master/slave circuits (lead/lag).
- Control of the refrigerant parameters (suction superheating, condensing pressure control).
- Capacity control based on water inlet (or outlet) temperature and compensated by rate of exchange of the return temperature
- Temperature setpoint offset based on the outside air temperature, or water inlet/outlet differential temperature or via a 0-10 V signal.
- Provision of a dual set point for the leaving water temperature activated by a remote contact closure signal or by the built in time clock
- Fluid temperature pull-down rate at start-up adjustable range from 0.11 °C to 1.1 °C per minute to prevent excessive demand spikes at start-up
- Programmable seven-day time schedule. Up to 14 holiday period definitions
- Night-time sound control using a capacity limit and a fan speed control to reduce the noise produced by the machine. Can be configured via a user-defined schedule.
- Balanced running times for compressors and pumps.
- Demand limit control (configurable from 0% to 100%) activated by remote contact closure
- Remote system interlock (customer servo).
- Operating status and alarm outputs.
- Installation, Operation and Maintenance manual, and machine spares part list shall be available in electronic format and easy accessible by connecting a laptop to the control panel
- Unit water pump start/stop control
- Water flow and external static pressure electronic calculation
- Electronic setting of the water pump speed and the water flow (unit equipped with variable-speed pump hydronic module)
- On/off control for external water pump (up to 2).
- Variable speed command of one external water loop pump by 0-10 V signal
- Low ambient protection to energize Water heat exchanger and hydronic system trace heating (optional).
- The pump starts up periodically to ensure that the pump seals are properly maintained during periods of inactivity.

Control diagnostics

Unit control display shall include the following information for fault diagnostics:

- Compressor lockout
- Protection against loss of charge
- Low fluid flow
- Water heat exchanger frost protection
- Thermistor and transducer malfunction
- Entering and leaving-fluid temperature
- Water heat exchanger and air heat exchanger pressure
- Unit starts number and run hours
- Compressor starts number and run hours
- Fan starts number and run hours
- Number of pump start-ups and hours of operation
- Quick test shall verify operation of every switch, fan, pump and compressor before chiller is started. Diagnostics shall include the ability to view the list of the 10 alarms currently active with clear language descriptions of the alarm event.
- Two alarm history buffers shall allow the user to store no less than 50 alarm events with clear language descriptions, time and date stamp event entry. One alarm history shall be dedicated to general alarms while the other shall only display major failures.
- The control system shall allow software upgrade without the need for new hardware modules.

Safeties

Unit shall be equipped with thermistors/transducers and all other control devices to protect from the following:

- Reverse rotation or wrong electrical power connection
- Low fluid temperature
- Thermal overload
- High Pressure control made by software and mechanical protection by pressure gauge opening
- Low suction pressure
- Electrical overload
- Loss of phase
- Low voltage power supply failure
- Low water flow rate.

Operating characteristics

Unit shall be capable of starting and running at outdoor ambient temperatures from -10 °C to 48 °C.

Unit shall be capable of starting up with 40 °C entering fluid temperature to the Water heat exchanger.

Electrical data

- Unit shall be supplied with main on/off disconnect switch without fuse.
- Single point power connection
- Unit shall operate on 3-phase power at the voltage shown in the equipment schedule.
- The control points shall be accessed via a terminal block.
- The unit shall be shipped with a factory-fitted controller.

Water circuit

Water circuit shall be rated for 10 bars maximum working pressure. Units with optional pump package are rated for 4 bars maximum working pressure.

Options

The following options can be fitted to the unit, as required.

Hydronic module

- The hydronic module shall be integrated in the chiller chassis without increasing its dimensions and include the following elements: Easily removable strainer, water pump with three-phase motor, accurate and reliable electronic water flow control (flow switch with paddle shall not be accepted), safety relief valve calibrated to 4 bar. Water flow and external static pressure electronic readings shall be available through operator user interface. Additional pressure/temperature taps (2) shall be factory installed to measure the pressure differential across the hydronic module.
- Water pump shall comply with Commission regulation (EU) N°547/2012 implementing Directive 2009/125/EC with regards to Eco-design requirements.
- The pump motors shall be totally enclosed, 3-phase type motors with permanently lubricated bearings and Class F insulation. The pump motors shall be IE2 efficiency level rated.
- Each pump shall be 100% factory tested per Hydraulic Standards.
- The pump shall be protected against cavitation through electronic pressure control at pump inlet.
- The pump casing shall be of cast iron with cathaphoretic coating.
- The impeller shall be designed using laser technology and made of AISI 316L stainless steel.
- A choice of 6 hydronic modules shall be available:
 - High-pressure single pump hydronic module.
 - High-pressure dual pump hydronic module
 - Low-pressure single pump hydronic module
 - Low-pressure dual pump hydronic module
 - High-pressure variable-speed single pump hydronic module
 - High-pressure variable-speed dual pump hydronic module
- The dual pump hydronic module shall have two independent electric motors and two independent impellers to ensure reliable operation.
- Cast iron body strainer with 1.2 mm mesh screen
- The water piping shall be protected against corrosion and equipped with drain and vent plugs.
- The piping and the water pump shall be fully insulated to prevent condensation (pump insulation using polyurethane foam and painted steel casing).
- Frost protection down to -20 °C shall be guaranteed by optional electric trace-heating (24 volt) and the water pump shall be automatically started by the controller safety logic in case of a risk of frost formation.
- The customer connections shall be Victaulic connections.

Additional specifications for variable-speed pump hydronic module

- Hydronic module with variable-speed single pump shall be equipped with one VFD (variable frequency drive) to save energy.
- Hydronic module with two variable-speed pumps shall be equipped with two VFDs (variable frequency drives) for full redundancy and to save energy.
- VFD drive along with Greenspeed® intelligence shall be able to vary the pump motor speed in the 30-50 Hz frequency range.
- Nominal unit water flow shall be established through electronic setting of the pump speed to achieve energy savings. Use of a regulating valve to set nominal water flow shall not be accepted.
- Water flow control based on compressor usage, constant system pressure difference or constant system temperature difference shall be available on choice.

Expansion vessel

A buffer tank shall be supplied with a hydronic module to protect the water circuits from excessive pressure.

Water heat exchanger frost protection

Trace heating provides protection against Heat exchanger, water piping freezing between 0°C and -20°C outside air temperature.

Water heat exchanger and hydronic module frost protection

Trace heating provides protection against Heat exchanger, water piping and hydronic module freezing between 0°C and -20°C outside air temperature.

Coil defrost resistance heaters

Electric heaters under the coils and the condensate pans to prevent from frost formation on the coils; compulsory in the heating mode, if the outdoor is below 0°C.

Welded water heat exchanger connection kit

Victaulic connection adapter for easy connection to the water mains.

Low noise level

Aesthetic and sound absorbing compressor enclosure to reduce noise level by 1 to 2 dB(A).

Very low sound level

Sound absorbing compressor enclosure with a stylish design combined with low-speed fans to reduce the noise level by 5 to 6 dB(A) in cooling mode.

Partial heat recovery

Unit equipped with one desuperheater on each refrigerant circuit for production of free high-temperature hot-water simultaneously with chilled or hot water production.

Corrosion protection, traditional coils

Fins made of pre-treated aluminium (polyurethane and epoxy) for improved corrosion resistance, recommended for moderate marine and urban environment.

Enclosure panels

Side enclosure panels at each end of the coil offer an enhanced design, and protect the coil and piping against impacts.

Grilles and enclosure panels

Metal grilles on the 4 unit sides, plus side enclosure panels at each end of the coil to protect against intrusion to the unit interior, to improve aesthetics while protecting coil and piping protection against impacts.

Soft starter

Electronic starter on each compressor to reduce the start-up current.

Power Factor Correction (PFC)

Additional capacitors are integrated to ensure a power factor (Cos phi) of 0.95 at full load.

High Static Fan (HSF)

Unit equipped with high static variable speed fan (maximum 200Pa), each fan being equipped with a connection flange allowing the connection to the ducting system.

Master/slave operation

- Two units connected by a communication bus shall work in tandem to maintain the water temperature of the system.
- The master unit shall be the only interface to control the operation of both cooling units.
- Up to 5 possible water loop configuration (parallel, common or dedicated pumps, series, etc.).
- Three balance modes: Disabled, only on failure, according to run times.
- Common pump management (external pump and units provided with flow switch only) or dedicated pump management (internal pump can be used).

Energy management module

Communication board with additional inputs/outputs

- Input contacts:
 - Setpoint reset by indoor air temperature sensor (10 kOhms) or by a 4 to 20 mA signal
 - Time schedule override
 - End of ice production (ice storage)
 - One additional demand limit volt-free input
 - Demand limitation by 0-10 V signal.
 - Additional customer interlock
- Output contacts:
 - Instantaneous heat pump capacity by 0-10 V signal
 - Alert indicator on cooler.
 - Complete shut-down due to a chiller fault
 - Boiler on/off command during winter season (heat mode by changeover or manual configuration).
 - Desuperheater customer water pump command ON/OFF.
 - 4 Additional heating stages on/off command.
 - Desuperheater pump management.

CCN to J-Bus gateway

Unit shall be supplied with factory-installed two-directional communication board to interface the unit with a JBUS Local Area Network (JBUS, ModBUS). Field programming for customisation is possible.

CCN to Lon gateway

Unit shall be supplied with factory-installed two-directional communication board to interface the unit with a LonWorks® Local Area Network (LON, i.e., LonWorks FT-10A ANSI/EIA-709.1). Field programming shall be required.

BACnet/IP gateway (compatibility with Touch Pilot control only)

Unit shall be supplied with factory-installed two-directional high-speed communication using BACnet protocol over Ethernet network (IP). This option shall allow unit integration with BACnet building automation system using Internet Protocol. This new generation of BACnet IP communication shall allow high speed communications with building management systems, no limitation in reading/writing controller points and shall use standardised alarm codes as defined with BACnet protocol. Field programming may be required.

Electric plug

230 V/0.8 A AC power supply for connecting a laptop.

Note: 30RQM Specification Guide is also available. Please contact Carrier representative for more information.



Order No.: 10019, 02.2017. Supersedes order No. 10019, 10.2016.
The manufacturer reserves the right to make any changes, without notice.



Quality and Environment
Management Systems
Approval

Manufactured by: Carrier SCS, Montluel, France.
Printed in the European Union.