



United Technologies

PRODUCT SELECTION DATA



- Easy and fast installation
- Hydronic module available
- Inverter technology compressor and fans
 - Superior reliability

Inverter Air-Cooled Liquid chillers &
Reversible Air to Water Heat Pumps

30RBV/30RQV 017-021



CARRIER participates in the ECP programme for LCP/HP
Check ongoing validity of certificate:
www.eurovent-certification.com
www.certiflash.com



30RBV/30RQV 017-021

Nominal cooling capacity 15-18 kW

Nominal heating capacity 17-21 kW

The Aquasnap Greenspeed liquid chiller/heat pump range was designed for commercial applications such as the air conditioning of offices, hotels and large residential houses.

The units integrate the latest technological innovations: Non-ozone depleting refrigerant R410A, DC inverter twin-rotary compressors, low-noise variable speed fans and microprocessor control.

With exceptional energy efficiency values the inverter chillers qualify for local tax reductions and incentive plans in all EU countries.

For added flexibility the Aquasnap Greenspeed units are available with or without hydraulic module integrated into the unit chassis, limiting the installation to straightforward operations like connection of the power supply and the water supply and return piping.



Features

The Aquasnap Greenspeed heat pump systems can be used with a wide choice of Carrier terminal fan coil units - cassettes, low, medium and high-pressure satellite units, console units, underceiling units and high-wall units.

Ecodesign is the European Directive that sets mandatory requirements for Energy related Products (ErP) to improve their energy efficiency. Carrier supports initiatives to reduce the environmental impact of its products.

Quiet operation

■ Compressors

- Low-noise INVERTER Twin rotary compressor with low vibration levels
- Advanced technology providing maximum energy-efficiency with high capacity available at peak conditions and optimised efficiency at low and mid compressor speeds. The Aquasnap Greenspeed heat pump DC inverter uses Intelligent Power Drive Unit (IPDU) hybrid inverter technology. An electronic management logic is used to optimised compressor operation in all conditions, minimised temperature fluctuation to give a perfect individual comfort control with significant reduction of energy consumption :

PWM: pulse width modulation of the direct current controls the compressor at partial load conditions, adjusting the frequency at fixed voltage. The compressor speed is fine-tuned and the system provides high-level comfort (no temperature fluctuations) at exceptionally efficient working conditions.

Compressor frequency is increased continuously up to the maximum level. This ensures that there are no current draw peaks in the start-up phase. Inverter ramp-up speed makes soft starts unnecessary and ensures immediate maximum power.

- The two rotary compression cylinders, offset from each other by 180°, and the DC brushless motor with the shaft in perfect balance ensure reduced vibration and noise, even at very low operating speeds. This results in an extremely wide range between minimum and maximum capacity with continuous operation, guaranteeing that the system is always optimised and provides maximum comfort at exceptionally high efficiency levels.
- Twin-rotary cylinders, low vibrations and low load to the shaft ensure highest compressor reliability and a long trouble-free operating life.
- All DC brushless twin-rotary compressors are equipped with internal system to secure the motor against oil issues due to colder climate.
- A double compressor shield for acoustic insulation further reduces noise levels.

■ Air heat exchanger section

- Vertical air heat exchanger coils
- The latest-generation low-noise fans are now even quieter and do not generate intrusive low-frequency noise
- Rigid fan installation for reduced start-up noise.

Easy and fast installation

■ Integrated hydronic module (option)

- Fixed speed water pump or variable speed circulator
- Water filter protecting the water pump against circulating debris
- High-capacity membrane expansion tank ensures pressurisation of the water circuit (option)
- Overpressure valve, set to 3 bar
- Thermal insulation and frost protection down to -20°C, using an electric resistance heater and pump cycling.
- Integrated water fill system to ensure correct water pressure (option)

No additional buffer tank required, simplifying and speeding up the installation process (to be checked with the water volume of installation).

■ Physical features

- Advanced circuit design and component selection has resulted in a compact unit with an exceptionally small footprint that is easy to transport even through narrow doors.

Reduced operating weight and a handle on the unit panels to facilitate transport.

- The unit is enclosed by easily removable panels, covering all components (except air heat exchanger and fans).

■ A neutral color (RAL 7035) to facilitate the integration in residential area

■ Simplified electrical connections

- Main disconnect switch with high trip capacity (option)
 - Transformer for safe 24 V control circuit supply included

■ Fast commissioning

- Systematic factory operation test before shipment
 - Quick-test function for step-by-step verification of the instruments, electrical components and motors.

Economical operation

■ Increased seasonal efficiency

- In accordance with EN 14825:2013, Average Climate, energy label reach A+ (see Physical data RQV units). The exceptionally high energy efficiency of the Aquasnap Greenspeed unit is the result of a long qualification and optimisation process.

■ Reduced maintenance costs

- Maintenance-free twin rotary compressors
 - Fast diagnosis of possible incidents and their history via the user interface WUI
 - R410A refrigerant is easier to use than other refrigerant blends

Environmental care

■ Ozone-friendly R410A refrigerant

- Chlorine-free refrigerant of the HFC group with zero ozone depletion potential
 - Very efficient - gives an increased energy efficiency ratio (EER)

■ Leak-tight refrigerant circuit

- Brazed refrigerant connections for increased leak-tightness
 - Verification of pressure transducers and temperature sensors without transferring refrigerant charge

Superior reliability

■ State-of-the-art concept

- Cooperation with specialist laboratories and use of limit simulation tools (finite element calculations) for the design of the critical components, e.g. motor supports, suction/discharge piping etc.

■ Auto-adaptive control

- Control algorithm prevents excessive compressor cycling and permits reduction of the water quantity in the hydronic circuit (Carrier patent)

■ Exceptional endurance tests

- Corrosion resistance tests in salt mist in the laboratory
 - Accelerated ageing test on components that are submitted to continuous operation: compressor piping, fan supports
 - Transport simulation test in the laboratory on a vibrating table.

NHC Control

NHC control associate with compressor and fan variable frequency driver combines intelligence with operating simplicity. The control constantly monitors all machine parameters and precisely manages the operation of compressor, expansion devices, fans and of the water heat exchanger water pump for optimum energy efficiency.

■ Ease-of-use

- NHC control can be associated with a new User interface (WUI) which allow an easy access to the configuration parameters (frequency compressor, refrigerant circuit temperature, sets points, air temp, entering water temp, alarm report...).

- This user interface is also very intuitive in its use. It allows reading and easy selection of the operating mode. The functions are represented by icons on the LCD backlit screen.

- To facilitate the use of this interface, 3 levels of access are available: end user, installer and factory.

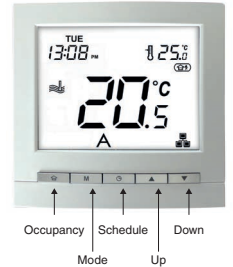

■ Key features

- Heating and cooling mode
 - Domestic hot water
 - Master/slave control of 4 units operating in parallel with operating time equalisation and automatic changeover in case of a unit fault (need Master slave sensor in accessory).
 - Scheduling period

■ Choice of control product

- 3 options are available to drive the 30 RBV / RQV 17-21:
 • Dry contact
 • User interface WUI
 • ModBus protocol

User Interface WUI

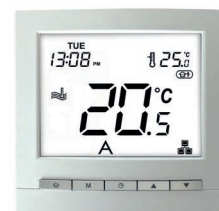

- This interface can be installed up to 50 m away. It is connected to the NHC board with a 4 wires cable.

- 2 installation possibilities:

- Inside the room (with remote interface accessory) : IAT sensor is an accessory, it is not mandatory to operate in remote user interface, because WUI has an internal sensor to measure the room temperature take with the internal sensor, setpoint selected is air temperature.
- On the HP/chiller (with local user interface option) : setpoint is on water temperature are water temperature



Local User Interface configuration

■ ModBus

Direct access with Modbus connection to set, configure and monitor the 30 RBV/RQV

■ Input remote contact :

- Remote On/Off Contact
- Remote Heat/Cool Contact: This switch is used to select the Cooling Mode (contact opened) or the Heating Mode (contact closed).
- Remote Economic Contact: This switch is used to select the regular Home Mode when contact is opened or the Economic Away Mode when contact is closed.
- Safety Input Contact: This switch is normally closed type, according to configuration it is used either to stop the unit, to ban the Heating Mode or to ban the Cooling Mode when contact is opened.

■ Large choice of Input Contacts

Several functions can be configured by the installer. They allow to adapt to the environment of the machine:

- Power Limitation / Night Mode: This switch is used to reduce the compressor maximum frequency to avoid noise.
- Off Peak: If the General Purpose Contact, configured to “Off Peak”, is closed then the Electric Heat Stages are not allowed.
- Loadshed Request: If the General Purpose Contact, configured to “Loadshed Request”, is closed then unit shall be stopped as soon as possible.
- Solar Input: If the General Purpose Contact, configured

to “Solar Input”, is closed then the unit is not allowed to run in Heating or DHW Mode because hot water is produced from a solar source.

- DHW Request Switch from tank : When this input is closed, the Domestic Hot Water production is requested (need DHW sensor delivered in accessory).
- DHW Priority : When this input is closed, the unit is switching to Domestic Hot Water production regardless of the Space Heating demand and the current DHW schedule (need DHW sensor delivered in accessory).
- Anti-Legionella Cycle Request : When this input is closed, the Domestic Hot Water production is requested with the Anti-Legionella setpoint.
- Summer Switch : This switch is used to select the Winter (contact opened) or the Summer Mode (contact closed).
- Energy Meter Input : This input is used to count the number of pulses received from an external energy meter (not supplied)
- External Alarm Indication Input : When this input is opened, alarm is tripped. This alarm is for information only, it does not affect the unit operation.

■ Output remote contact available

2 Output contacts could be chosen on the NHC board, upon configuration for the following purposes:

alert, alarm , Standby, running (Cool, Heat, DHW or Defrost Modes), IAT Reached, electrical Heat Stage 2, electrical Heat Stage 3

Type key

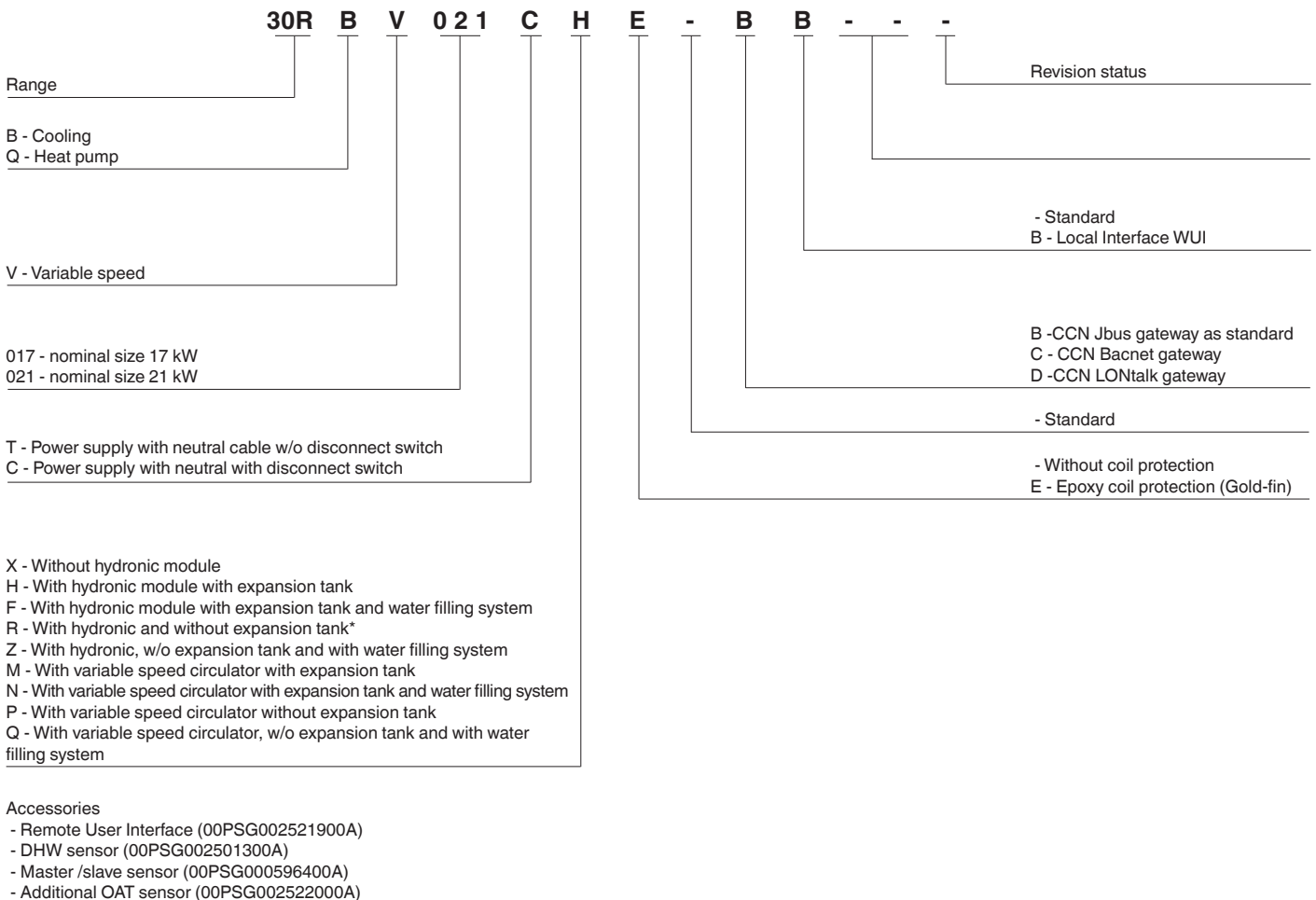

Hydronic module

The hydronic module reduces the installation time. The unit is factory-equipped with the main hydronic components required for the installation: screen filter, water pump, expansion tank and relief valve.

The water heat exchanger and the hydronic module are protected against frost down to -20°C , using an electric resistance heater (standard) and pump cycling. However, the use of MPG (Mono Propylene Glycol) can effectively protect the installation even in case of power failure

The hydronic module is integrated into the unit without increasing its dimensions and saves the space normally used for the water pump.

2 Hydronics modules are available in option :

- With fixed speed pump
- With Variable speed circulator

Physical and electrical data

30 RBV/RQV	017/021 Fixed Speed	017/021 Variable Speed
Hydronic module		
Expansion tank volume	l 8	8
Maximum water-side operating pressure	kPa 300	300
Pumps		
Water pump	Pump, screen filter, expansion tank, flow switch, relief valve	
Power input*	kW 0.82	0.31
Nominal operating current draw*	A 1.60	1.57

* Nominal conditions: evaporator entering/leaving water temperature $12^{\circ}\text{C}/7^{\circ}\text{C}$, outside air temperature 35°C , evaporator fouling factor = $0 \text{ m}^2 \text{ K/kW}$.
Gross performances, not in accordance with EN14511-3:2013. These performances do not take into account the correction for the proportional heating capacity and power input generated by the water pump to overcome the internal pressure drop in the heat exchanger.

Typical hydronic circuit diagram

With the hydronic module 17-21 kW

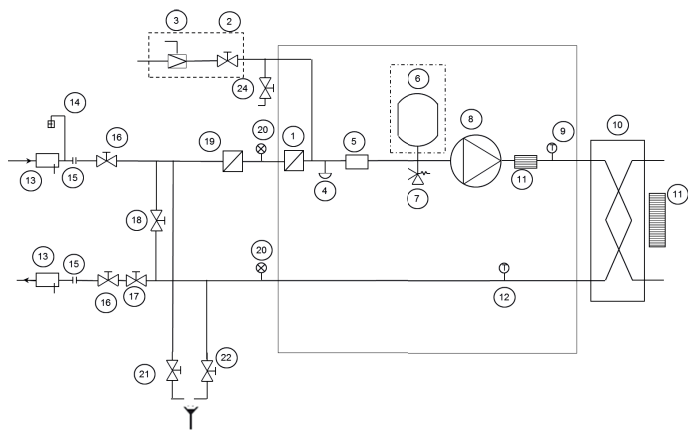

Without the hydronic module 17-21 kW

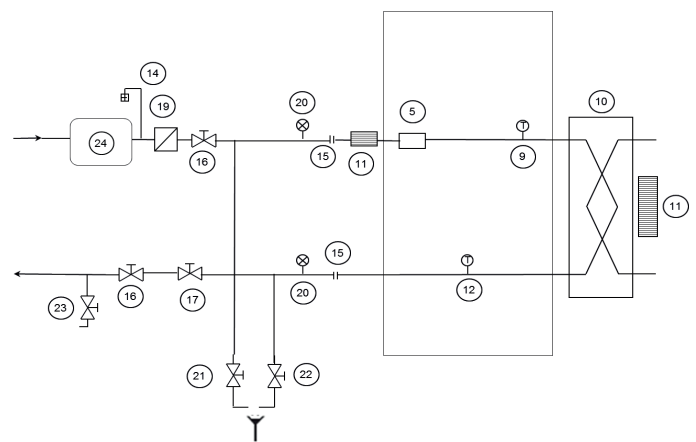

- Components provided with unit
- - - Water filling system (option)
- · - · Expansion tank (option)

Legend

Hydronic components

1. Mesh filter
2. On/off valve (water filling - optional)
3. Pressure reducer (water filling - optional)
4. Water drain valve
5. Paddle flow switch
6. Expansion tank
7. Safety valve
8. Pump
9. Temperature sensor
10. Brazed Plate Heat Exchanger
11. Anti-freeze electric heater
12. Temperature sensor

System components

13. Pocket for temperature sensor
14. Air purge
15. Flexible connections
16. On/off valve
17. Water flow control valve (factory supplied only with hydronic module option but to be installed on site)
18. Bypass valve for anti-freeze protection (when, in winter, on/off valve are closed)
19. Mesh filter (mandatory for a unit without hydronic kit)
20. Pressure gauge
21. Water drain valve from the plant
22. Water drain valve from refrigerant – water exchanger
23. Charge valve
24. Buffer tank (if required)

Physical data, 30RBV units

30RBV			017	021	
Cooling					
Standard unit	C1	Nominal capacity	kW	15,6	18,6
Full load performances*	C1	EER	kW/kW	3,3	3,1
	C1	Eurovent class cooling		A	A
	C2	Nominal capacity	kW	21,6	25,5
	C2	EER	kW/kW	4,0	3,9
	C2	Eurovent class cooling		A	A
Seasonal efficiency		ESEER	kW/kW	4,48	4,56
Sound levels					
Standard unit					
Sound power level ⁽²⁾			dB(A)	71	74
Sound pressure level at 10 m ⁽³⁾			dB(A)	40	43
Dimensions - Standard unit					
Length ⁽⁵⁾			mm	1109	1109
Width			mm	584	584
Height			mm	1579	1579
Operating Weight⁽¹⁾					
Standard unit			kg	168,9	176,9
Compressors					
			Rotary compressor	1	1
Refrigerant					
			R410A		
Charge ⁽¹⁾			kg	6,25	6,25
Capacity control					
Minimum capacity ⁽⁶⁾			NHC control		
			%	33%	41%
Condenser					
			Grooved copper tubes, aluminium fins		
Fans - Standard unit					
			Axial type fan		
Quantity				2	2
Maximum total air flow			l/s	2000	2400
Maximum rotational speed			rps	14	16
Evaporator					
			Brazed plate heat exchanger		
Water volume			l	1,52	1,9
Max water-side operating pressure without hydronic module			kPa	1000	1000
Hydronic module (option)					
			Pump, relief valve, paddle flow switch, expansion tank (option)		
Pump			Centrifugal pump (fixed speed or variable speed)		
Expansion tank volume			l	8	8
Max. water-side operating pressure with hydronic module ⁽⁴⁾			kPa	300	300
Water connections (Without Hydronic Module)					
Inlet diameter (BSP GAS)			inch	1	1
Outlet diameter (BSP GAS)			inch	1	1
Water connections (With Hydronic Module)					
Inlet diameter (BSP GAS)			inch	1-1/4	1-1/4
Outlet diameter (BSP GAS)			inch	1	1
Water Filling System (Option)					
Diameter (BSP GAS)			inch	1/2	1/2
Chassis paint colour					
			Colour code:	RAL 7035	RAL 7035

* In accordance with standard EN 14511-3:2013

C1 Cooling mode conditions : evaporator water entering/leaving temperature 12°C/7°C, outside air temperature 35°C, evaporator fouling factor 0m² K/W

C2 Cooling mode conditions : evaporator water entering/leaving temperature 23°C/18°C, outside air temperature 35°C, evaporator fouling factor 0m² K/W

(1) Values are guidelines only. Refer to the unit nameplate.

(2) In dB ref=10⁻¹² W, (A) weighting. Declared dualnumber noise emission values in accordance with ISO 4871 (with an associated uncertainty of +/-3dB(A)). Measured in accordance with ISO 9614-1 and certified by Eurovent.

(3) In dB ref 20 µPa, (A) weighting. Declared dualnumber noise emission values in accordance with ISO 4871 (with an associated uncertainty of +/-3dB(A)). For information, calculated from the sound power level Lw(A).

(4) Min. water-side operating pressure with fixed speed hydronic module is 50 kPa and with variable speed hydronic module is 40 kPa.

(5) Length = 1141 mm if main disconnect switch

(6) Cooling Eurovent condition



Eurovent certified values

Physical data, 30RQV units

30RQV				017	021
Cooling					
Standard unit	C1	Nominal capacity	kW	14,9	18,6
Full load performances*	C1	EER	kW/kW	3,0	3,1
	C1	Eurovent class cooling		B	A
	C2	Nominal capacity	kW	19,8	25,8
	C2	EER	kW/kW	3,9	3,8
	C2	Eurovent class cooling		A	A
Seasonal efficiency		ESEER	kW/kW	4,01	3,85
Heating					
Standard unit	H1	Nominal capacity	kW	17,1	21,1
Full load performances*	H1	COP	kW/kW	4,1	4,1
	H1	Eurovent class heating		A	A
	H2	Nominal capacity	kW	16,2	20,0
	H2	COP	kW/kW	3,4	3,3
	H2	Eurovent class heating		A	A
	H3	Nominal capacity	kW	15,3	19,1
	H3	COP	kW/kW	2,7	2,7
Seasonal efficiency**	H3	SCOP	kW/kW	3,1	2,9
	H3	ηs heat	%	121	113
	H3	Prated	kW	9,5	15,43
	H3	Annual Energy consumption	KWh	6269	10980
	H3	Energy class		A+	A+
Sound levels					
Standard unit					
Sound power level ⁽²⁾			dB(A)	71	74
Sound pressure level at 10 m ⁽²⁾			dB(A)	40	43
Dimensions - Standard unit					
Length ⁽⁵⁾			mm	1109	1109
Width			mm	584	584
Height			mm	1579	1579
Operating Weight⁽¹⁾					
Standard unit			kg	190,9	199,4
Compressors					
			Rotary compressor	1	1
Refrigerant					
			R410A		
Charge ⁽¹⁾			kg	8	8
Capacity control					
Minimum capacity ⁽⁶⁾			NHC control		
			%	33%	41%
Air heat exchanger					
				Grooved copper tubes, aluminium fins	
Fans - Standard unit					
				Axial type fan	
Quantity				2	2
Maximum total air flow			l/s	2000	2400
Maximum rotational speed			rps	14	16
Water heat exchanger					
				Brazen plate heat exchanger	
Water volume			l	1,52	1,9
Max water-side operating pressure without hydronic module			kPa	1000	1000
Hydronic module (option)					
Pump				Pump, relief valve, paddle flow switch, expansion tank (option)	
Expansion tank volume			l	8	8
Max. water-side operating pressure with hydronic module ⁽⁴⁾			kPa	300	300
Water connections (Without Hydronic Module)					
Inlet diameter (BSP GAS)			inch	1	1
Outlet diameter (BSP GAS)			inch	1	1
Water connections (With Hydronic Module)					
Inlet diameter (BSP GAS)			inch	1-1/4	1-1/4
Outlet diameter (BSP GAS)			inch	1	1
Water Filling System (Option)					
Diameter (BSP GAS)			inch	1/2	1/2
Chassis paint colour					
			Colour code:	RAL 7035	RAL 7035

* In accordance with standard EN 14511-3:2013

** In accordance with standard EN 14825:2013, Average climate

C1 Cooling mode conditions : evaporator water entering/leaving temperature 12°C/7°C, outside air temperature 35°C, evaporator fouling factor 0m² K/W

C2 Cooling mode conditions : evaporator water entering/leaving temperature 23°C/18°C, outside air temperature 35°C, evaporator fouling factor 0m² K/W

H1 Heating mode conditions : Water heat exchanger water entering/leaving temperature 30°C/35°C, fouling factor 0m² K/W. Outside air temperature 7°C db / 6°C wb

H2 Heating mode conditions : Water heat exchanger water entering/leaving temperature 40°C/45°C, fouling factor 0m² K/W. Outside air temperature 7°C db / 6°C wb

H3 Heating mode conditions : Water heat exchanger water entering/leaving temperature 47°C/55°C, fouling factor 0m² K/W. Outside air temperature 7°C db / 6°C wb

(1) Values are guidelines only. Refer to the unit nameplate.

(2) In dB ref=10⁻¹² W, (A) weighting. Declared dualnumber noise emission values in accordance with ISO 4871 (with an associated uncertainty of +/-3dB(A)). Measured in accordance with ISO 9614-1 and certified by Eurovent.

(3) In dB ref 20 µPa, (A) weighting. Declared dualnumber noise emission values in accordance with ISO 4871 (with an associated uncertainty of +/-3dB(A)). For information, calculated from the sound power level Lw(A).

(4) Min. water-side operating pressure with fixed speed hydronic module is 50 kPa and with variable speed hydronic module is 40 kPa.

(5) Length = 1141 mm if main disconnect switch

(6) Cooling Eurovent condition



Eurovent certified values

Electrical data, 30RBV/RQV units

30RBV / RQV (full options)		17	21
Power circuit			
Nominal power supply	V-ph-Hz	400-3+N-50	400-3+N-50
Voltage range	V	360-440	360-440
Control circuit supply			
		24V AC via internal transformer	
Nominal unit current drawn (Un) *	A	12,5	14,3
Maximum unit power input (Un) **	kW	10,8	12,4
Cos Phi unit at maximum power **		0,93	0,93
Maximum unit current drawn (Un-10%***)	A	18,5	21,2
Maximum unit current drawn (Un) ****	A	16,7	19,2
Maximum Start-up current, standard unit †	A	Not Applicable (less than the operating current)	

* Conditions equivalent to the standardised Eurovent conditions (evaporator water entering-leaving temperature = 12 °C/7 °C, outside air temperature = 35 °C).
 ** Power input, compressors and fans, at the unit operating limits (saturated suction temperature 15 °C, saturated condensing temperature 68.3 °C) and nominal voltage of 400 V (data given on the unit nameplate).
 *** Maximum unit operating current at maximum unit power input and at 360 V.
 **** Maximum unit operating current at maximum unit power input and at 400 V (values given on the unit nameplate).
 † Maximum instantaneous start-up current at operating limits (maximum operating current of the smallest compressor(s) + fan current + locked rotor current of the largest compressor).
 Fan motor electrical data: at Eurovent equivalent conditions and motor ambient air temperature of 50 °C at 400 V: 3.8 A, start-up current 20 A, power input 1.75 kW

New energy efficiency metric: SCOP

Because buildings have a thermal load depending on outdoor air temperature

The Seasonal Coefficient of Performance (SCOP) is a new European parameter to evaluate the energy efficiency of heat pumps. It replaces the Coefficient of Performance (COP), which measured the ratio of power consumed to power produced in the heating mode on a single operating

point. Unlike its predecessor, the SCOP is representative of operation during the heating season as it includes seasonal variations by defining several realistic measurement points. Together, these contribute to classification in the correct energy efficiency class.

SCOP versus COP efficiency (for heat pumps)



TEMPERATURE

COP	SCOP
1 temperature condition: 7°C	Several rating temperatures: -10°C to 16°C (average climate)



CAPACITY (KW)

COP	SCOP
Full load	Partial load + Full load



AUXILIARY MODES (KWH)

COP	SCOP
No auxiliary power modes taken into consideration	Includes consumption auxiliary modes: - Standby mode - Off mode - Thermostat off...



HOURS

COP	SCOP
N/A	Number of hours occurring at each air temperature (bin hours)

SCOP Calculation

SCOP is the ratio between annual heating demand and annual energy input over an entire heating season.

$$\text{SCOP} = \frac{\text{ANNUAL HEATING DEMAND}}{\text{ANNUAL ENERGY INPUT}^*}$$

* Annual energy input:
 - Compressor running (SCOPon)
 - Compressor not running; thermostat OFF, standby, OFF mode & crankcase heater
 - Backup heater to supplement heat pump capacity

η_s: seasonal primary energy efficiency metrics:

In order to compare the energy efficiency of products using different sources of energy, such as boilers (gas, fuel) and electric heat pumps, the Ecodesign regulation introduces a new measurement expressed in primary energy: η_s (eta s).

$$\eta_s = \text{SCOP}/2.5^* \times 100 - i^{**}$$

Primary energy



Primary energy



Electricity



In Europe, on average, 2.5 kW*** of primary energy is required to generate 1 kW of electricity.

** Air source heat pump i = 3
 Water source heat pump: i = 8

*** Source: EU Regulation 813/2013

Average climate with circulator

Medium temp (47/55)

30RQV			Pdesign	Annual power input with backup heater	Sound power level	Energy Class
Size (kW)	ηs	SCOP	kW	kWh	dB(A)	
17	118	3,03	9,11	6189	71	A+
21	111	2,85	15,07	10889	74	A+

Low temp (30/35)

30RQV			Pdesign	Annual power input with backup heater	Sound power level	Energy Class
Size (kW)	ηs	SCOP	kW	kWh	dB(A)	
17	144	3,68	9,25	5169	71	A+
21	139	3,56	16,64	9625	74	A+

Colder climate with circulator

Medium temp (47/55)

30RQV			Pdesign	Annual power input with backup heater	Sound power level	Energy Class
Size (kW)	ηs	SCOP	kW	kWh	dB(A)	
17	108	2,78	16,41	13894	71	A+
21	92	2,37	22,77	22602	74	A+

Low temp (30/35)

30RQV			Pdesign	Annual power input with backup heater	Sound power level	Energy Class
Size (kW)	ηs	SCOP	kW	kWh	dB(A)	
17	121	3,09	13,65	10390	71	A+
21	117	3,01	24,47	19152	74	A+

Warmer climate with circulator

Medium temp (47/55)

30RQV			Pdesign	Annual power input with backup heater	Sound power level	Energy Class
Size (kW)	ηs	SCOP	kW	kWh	dB(A)	
17	149	3,80	12,50	4383	71	A+
21	143	3,65	16,37	5983	74	A+

Low temp (30/35)

30RQV			Pdesign	Annual power input with backup heater	Sound power level	Energy Class
Size (kW)	ηs	SCOP	kW	kWh	dB(A)	
17	225	5,71	14,67	3425	71	A+
21	192	4,87	21,06	5764	74	A+

Sound spectrum, 30RBV/RQV units

30RBV17 - Variable speed hydraulic kit option			30RQV17 - Variable speed hydraulic kit option			30RBV21 - Variable speed hydraulic kit option			30RQV21 - Variable speed hydraulic kit option		
Load*	Sound power level		Load*	Sound power level		Load*	Sound power level		Load*	Sound power level	
-	-	dB(A)	100%	71	dB(A)	-	-	dB(A)	100%	74	dB(A)
100%	71	dB(A)	100%	71	dB(A)	100%	74	dB(A)	100%	74	dB(A)
74%	71	dB(A)	74%	68	dB(A)	74%	69	dB(A)	74%	73	dB(A)
48%	64	dB(A)	48%	65	dB(A)	48%	66	dB(A)	48%	67	dB(A)
21%	60	dB(A)	21%	61	dB(A)	21%	63	dB(A)	21%	65	dB(A)

* SEER Conditions

Operating limits

Operating range for 30RBV

Evaporator Water Temperature	°C	Minimum	Maximum
Entering water temperature at start-up		6 ***	30
Leaving water temperature during operation		5 ***	18
Condenser Air Temperature	°C	Minimum	Maximum
Standard unit		-10 **	46

** For operation at an outdoor ambient temperature below 0°C (cooling mode and heating mode), the water freeze protection should be available and / or the water loop can be protected against frost by the installer, using an anti-freeze solution.
 *** Minimum leaving water temperature of 7°C and minimum entering water temperature of 7.5°C for air temperature of -10°C to 0°C for 30RBV 17-21

30RBV

Operating range 30RBV 17-21 units

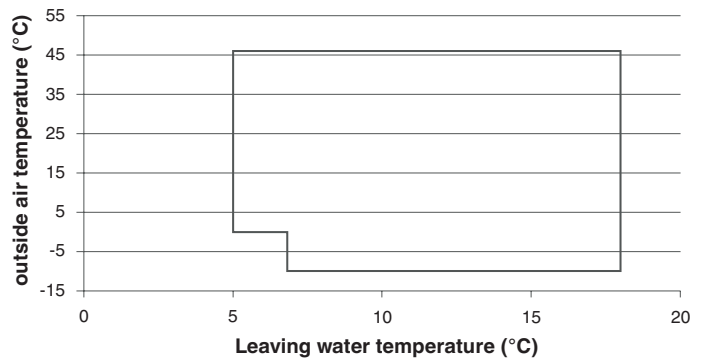

Operating range for 30RQV

Cooling Cycle			
Evaporator Water Temperature	°C	Minimum	Maximum
Entering water temperature at start-up		6	30
Leaving water temperature during operation		5	18
Condenser Air Temperature	°C	Minimum	Maximum
Standard unit		0	46
Heating Cycle			
Condenser Water Temperature	°C	Minimum	Maximum
Entering water temperature at start-up		10	45
Leaving water temperature during operation		20	60 / 57 *
Evaporator Air Temperature	°C	Minimum	Maximum
Standard unit		-20 **	30

* 60°C for 30RQV 17 and 57°C for 30RQV 21
 ** For operation at an outdoor ambient temperature below 0°C (cooling mode and heating mode), the water freeze protection should be available and / or the water loop can be protected against frost by the installer, using an anti-freeze solution.

30RQV (cooling mode)

Operating range 30RQV 17-21 units, Cooling Mode

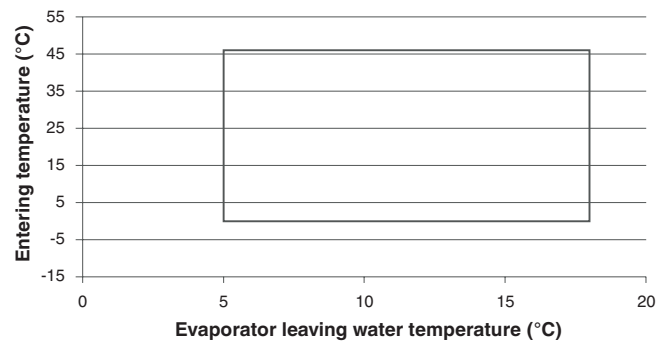

30RQV (heating mode)

Operating range 30RQV 17-21 units, Heating Mode

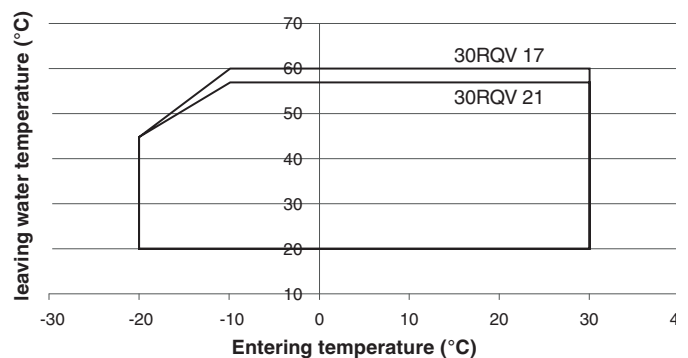

Available static system pressure

Available external static pressure for unit with fixed speed hydronic module 17 and 21kW

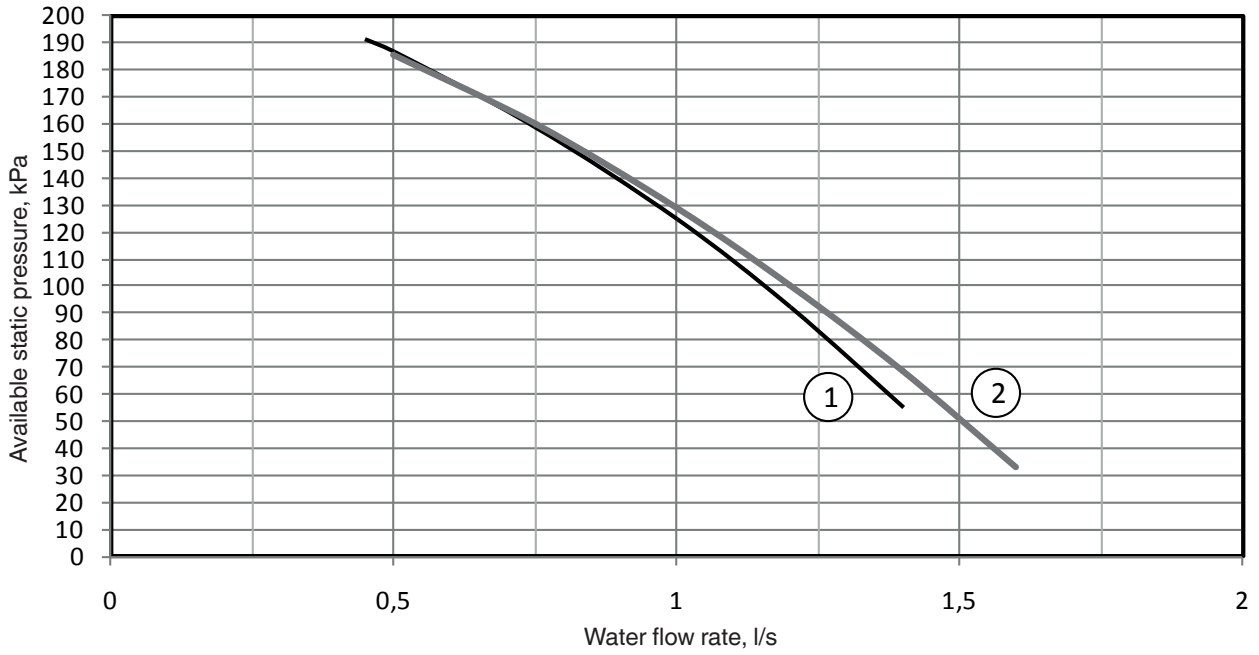

Legend

- 1. 30RBV-RQV 17
- 2. 30RBV-RQV 21

Available external static pressure for 17kW unit with variable speed hydronic module

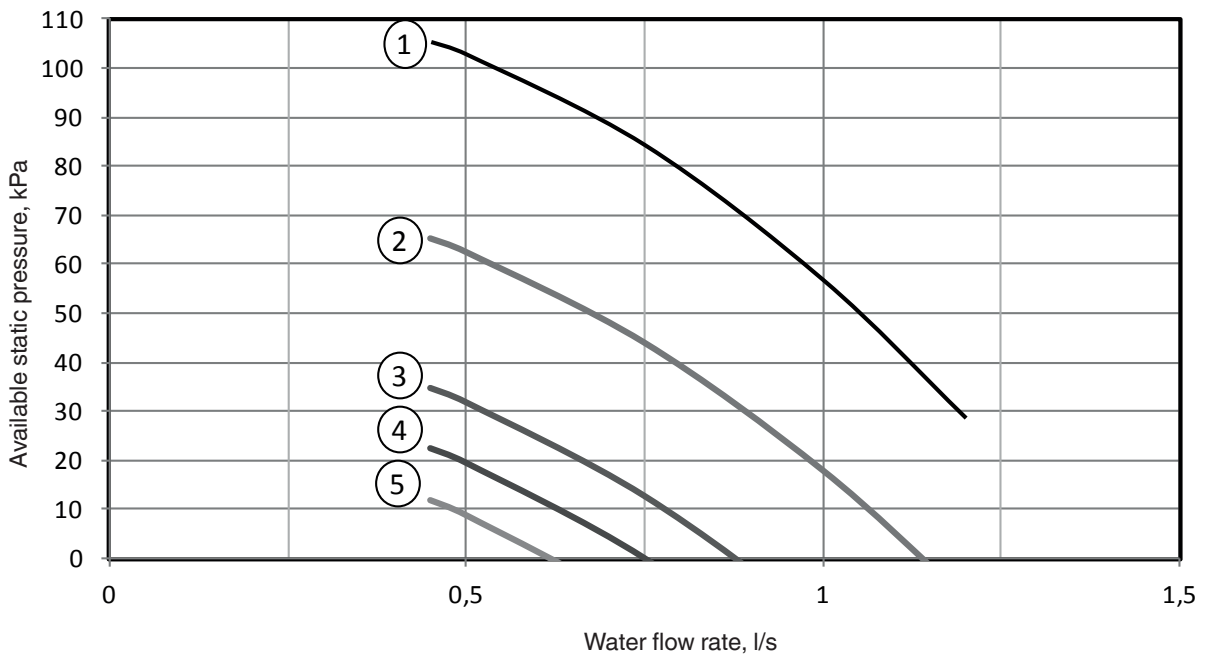

Legend

- 1. Pump Speed = 100%
- 2. Pump Speed = 75%
- 3. Pump Speed = 50%
- 4. Pump Speed = 38%
- 5. Pump Speed = 25%

Available external static pressure for 21kW unit with variable speed hydronic module

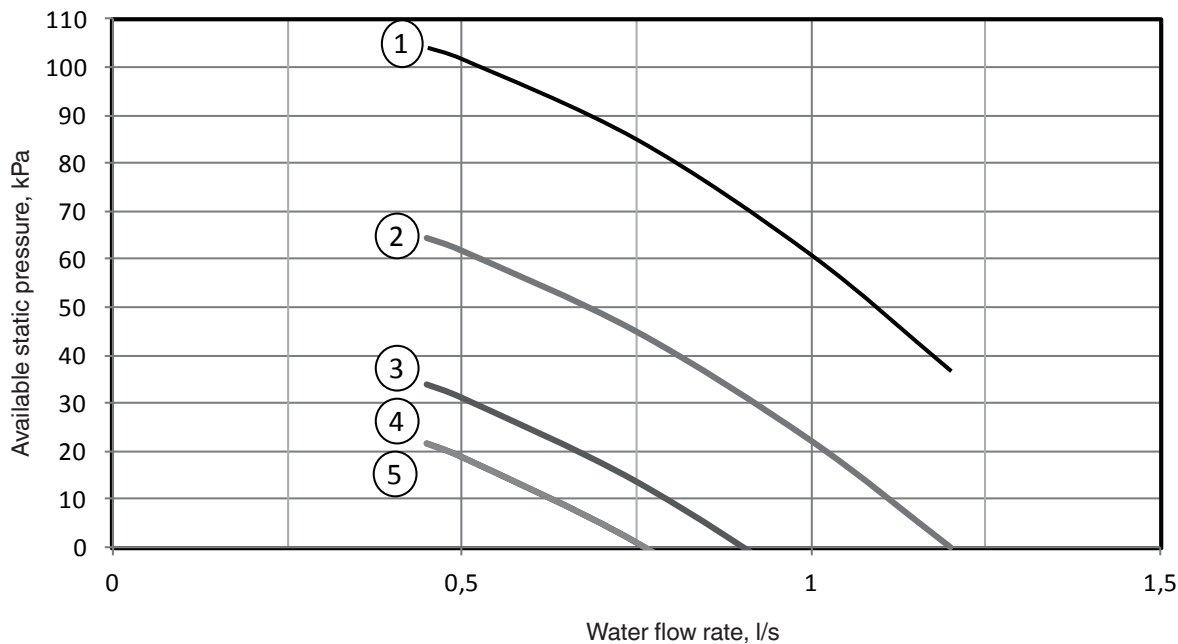

Legend

1. Pump Speed = 100%
2. Pump Speed = 75%
3. Pump Speed = 50%
4. Pump Speed = 38%
5. Pump Speed = 25%

System minimum water volume

$$\text{Vol(l)} = \text{CAP (kW)} \times \text{N}$$

Application	N
Air conditioning	3,5
Heating or domestic hot water application	6
Industrial process cooling	See note

Note : For industrial process cooling applications, where high stability of water temperature levels must be achieved, the values above must be increased. We recommend consulting the factory for these particular applications.

BPHE water flow rate

30RBV/RQV units without hydronic module		
	Minimum water flow rate, l/s	Maximum water flow rate, l/s
17	0,45	1,3
21	0,57	1,5

30RBV/RQV units with fixed speed hydronic module		
	Minimum water flow rate, l/s	Maximum water flow rate, l/s
17	0,45	1,4
21	0,57	1,6

30RBV/RQV units with variable speed hydronic module		
	Minimum water flow rate, l/s	Maximum water flow rate, l/s
17	0,45	1,2
21	0,57	1,2

System maximum water volume

Water maximum volume (L)		
3RBV/RQV 17-21		
Static pressure (bar)	1,5	3
Fresh water	200	50
Ethylen glycol 10%	150	28
Ethylen glycol 20%	110	28
Ethylen glycol 30%	90	23
Ethylen glycol 40%	76	19

Dimensions/clearances

30RBV/RQV 017-021

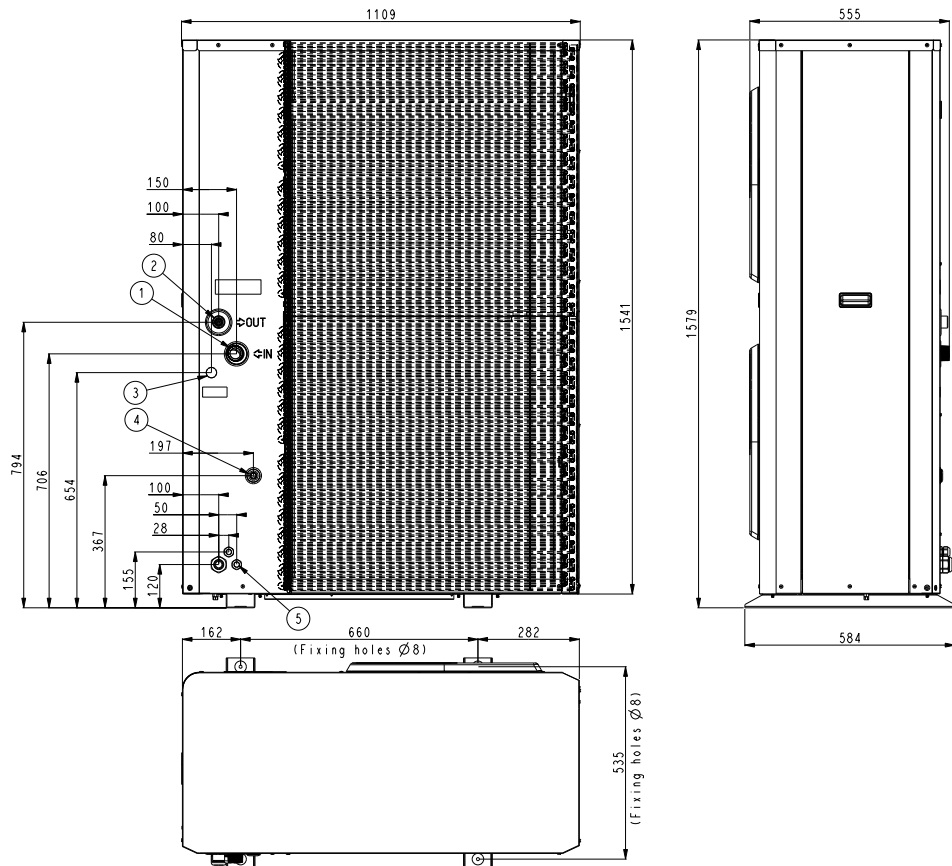

Legend

All dimensions are in mm

- 1. Water inlet
- 2. Water outlet
- 3. Fill kit connection
- 4. Safety valve outlet
- 5. Electrical connections

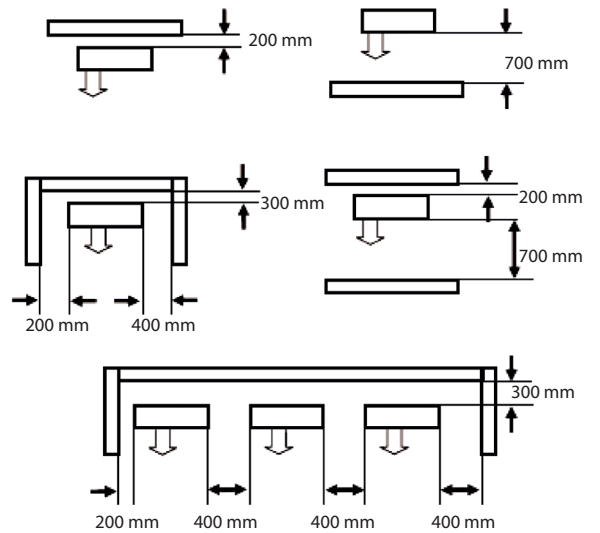
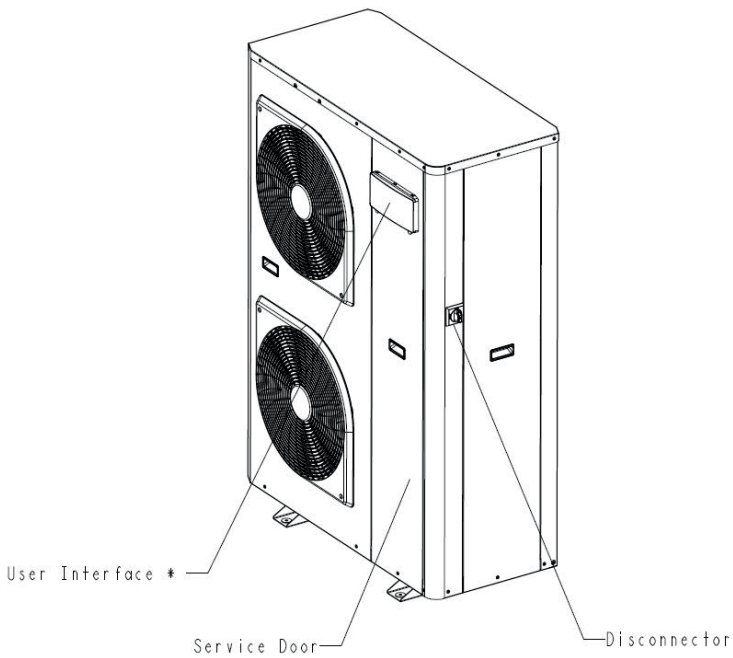

Cooling capacities in accordance with EN14511-3 : 2013



30RBV 17 Unit

LWT °C		Outside air temperature, °C																				
		10							15							25						
		Qc kW			EER kW/kW			q l/s	Qc kW			EER kW/kW			q l/s	Qc kW			EER kW/kW			q l/s
Nom	Min	Max	Nom	Min	Max	Nom	Nom	Min	Max	Nom	Min	Max	Nom	Nom	Min	Max	Nom	Nom	Min	Max	Nom	
30RBV 17	5	15,97	6,54	15,98	5,09	12,79	5,09	0,763	15,73	6,48	15,73	4,82	11,47	4,82	0,75	15,07	5,51	15,07	4,08	4,87	4,08	0,719
30RBV 17	7	16,89	7,36	16,89	5,25	26,33	5,25	0,807	16,64	6,93	16,64	4,99	12,98	4,99	0,795	15,99	6,20	15,99	4,26	6,29	4,26	0,764
30RBV 17	10	18,28	7,83	18,29	5,46	21,94	5,46	0,874	18,07	7,65	18,07	5,24	15,95	5,23	0,864	17,44	6,50	17,45	4,53	5,72	4,53	0,834
30RBV 17	15	20,77	13,60	20,77	5,80	7,56	5,80	0,995	20,98	8,59	20,98	5,94	15,50	5,95	1,005	20,06	7,91	20,06	5,01	8,31	5,01	0,961
30RBV 17	18	23,16	14,67	23,16	6,69	7,97	6,69	1,11	23,05	14,81	23,05	6,53	8,27	6,52	1,105	21,74	8,67	21,74	5,30	9,57	5,30	1,042

LWT °C		Outside air temperature, °C																				
		35							45													
		Qc kW			EER kW/kW			q l/s	Qc kW			EER kW/kW			q l/s							
Nom	Min	Max	Nom	Min	Max	Nom	Nom	Min	Max	Nom	Min	Max	Nom	Nom	Min	Max	Nom					
30RBV 17	5	14,41	5,71	15,43	3,09	3,43	2,98	0,688	12,90	7,68	12,92	2,41	2,46	2,41	0,62							
30RBV 17	7	15,60	6,13	16,36	3,25	3,69	3,09	0,745	13,70	8,20	13,72	2,51	2,60	2,51	0,65							
30RBV 17	10	16,68	6,81	17,82	3,42	4,12	3,26	0,798	14,96	9,02	14,98	2,66	2,81	2,66	0,72							
30RBV 17	15	19,17	8,03	20,45	3,75	4,99	3,55	0,918	17,23	10,51	17,25	2,92	3,20	2,92	0,83							
30RBV 17	18	21,61	8,84	22,14	4,02	5,63	3,73	1,036	18,68	11,48	18,71	3,08	3,45	3,08	0,90							

Legend

LWT Leaving water temperature, °C
 Qc Cooling capacity, kW
 Nom Nominal
 Min Minimum
 Max Maximum
 EER Energy Efficiency Ratio, kW/kW
 q Evaporator water flow rate, l/s

Application data

Standard units, refrigerant: R-410A
 Evaporator entering/leaving water temperature difference: 5 K or minimum mass flow rate
 Evaporator fluid: water
 Fouling factor: 0 m² K/W
 Performances in accordance with EN 14511-3:2011.

Cooling capacities

30RBV 21 Unit

LWT °C		Outside air temperature, °C																				
		10							15							25						
		Qc kW			EER kW/kW			q l/s	Qc kW			EER kW/kW			q l/s	Qc kW			EER kW/kW			q l/s
Nom	Min	Max	Nom	Min	Max	Nom	Nom	Min	Max	Nom	Min	Max	Nom	Nom	Min	Max	Nom	Nom	Min	Max	Nom	
30RBV 21	5	20,37	9,25	24,19	5,07	7,12	4,14	0,971	20,23	8,85	25,66	4,70	5,51	4,05	0,965	19,41	8,53	24,09	3,96	4,76	3,32	0,925
30RBV 21	7	21,48	9,78	25,88	5,18	7,40	4,39	1,025	21,37	9,36	27,34	4,83	5,73	4,24	1,020	20,57	9,06	25,49	4,12	5,01	3,41	0,982
30RBV 21	10	23,19	10,60	28,33	5,31	7,82	4,67	1,108	23,45	10,45	29,93	5,21	6,79	4,48	1,121	22,39	10,01	27,64	4,35	5,59	3,55	1,070
30RBV 21	15	27,32	12,07	32,94	6,32	8,50	5,13	1,308	27,23	12,20	34,07	5,88	8,24	4,71	1,304	25,65	11,63	31,49	4,72	6,52	3,75	1,228
30RBV 21	18	29,83	13,00	35,35	6,80	8,88	5,24	1,43	29,65	12,91	36,72	6,24	7,96	4,83	1,421	27,72	12,72	33,93	4,94	7,19	3,87	1,328

LWT °C		Outside air temperature, °C																				
		35							45													
		Qc kW			EER kW/kW			q l/s	Qc kW			EER kW/kW			q l/s							
Nom	Min	Max	Nom	Min	Max	Nom	Nom	Min	Max	Nom	Min	Max	Nom									
30RBV 21	5	17,73	9,08	22,97	3,06	3,52	2,63	0,845	15,84	8,82	17,04	2,34	2,40	2,28	0,76							
30RBV 21	7	18,63	9,67	24,32	3,12	3,71	2,71	0,889	16,85	9,40	18,11	2,44	2,52	2,37	0,80							
30RBV 21	10	20,52	10,59	26,44	3,37	4,03	2,83	0,981	18,43	10,31	19,78	2,59	2,71	2,50	0,88							
30RBV 21	15	23,57	12,25	30,17	3,68	4,59	3,02	1,128	21,24	11,94	22,76	2,84	3,05	2,73	1,02							
30RBV 21	18	25,51	13,33	32,56	3,87	4,95	3,12	1,223	23,04	12,99	24,66	3,00	3,27	2,87	1,10							

Legend

LWT Leaving water temperature, °C
 Qc Cooling capacity, kW
 Nom Nominal
 Min Minimum
 Max Maximum
 EER Energy Efficiency Ratio, kW/kW
 q Evaporator water flow rate, l/s

Application data

Standard units, refrigerant: R-410A
 Evaporator entering/leaving water temperature difference: 5 K or minimum mass flow rate
 Evaporator fluid: water
 Fouling factor: 0 m² K/W
 Performances in accordance with EN 14511-3:2011.

Cooling capacities in accordance with EN14511-3 : 2013



30RQV 17

LWT °C		Outside air temperature, °C																					
		10							15							25							
		Qc			EER				q	Qc			EER				q	Qc			EER		
kW			kW/kW				l/s	kW			kW/kW				l/s	kW			kW/kW				l/s
Nom Min Max			Nom Min Max				Nom	Nom Min Max			Nom Min Max				Nom	Nom Min Max			Nom Min Max				Nom
30RQV 17	5	15,34	13,05	15,34	5,04	4,72	5,04	0,73	15,06	9,65	15,06	4,26	5,48	4,26	0,72	14,16	8,78	14,16	3,67	4,18	3,67	0,68	
30RQV 17	7	16,25	13,84	16,25	5,20	4,98	5,20	0,78	15,97	10,31	15,98	4,43	6,07	4,43	0,76	15,31	9,40	15,31	3,93	4,47	3,93	0,73	
30RQV 17	10	17,63	7,77	17,63	5,44	7,20	5,44	0,84	17,39	6,06	17,39	4,67	8,92	4,66	0,83	16,74	5,14	16,74	4,20	4,34	4,20	0,80	
30RQV 17	15	20,13	8,29	20,13	5,79	7,30	5,79	0,96	19,94	6,81	19,94	5,05	8,84	5,05	0,95	19,37	6,00	19,37	4,66	5,19	4,66	0,93	
30RQV 17	18	21,68	8,92	21,69	5,98	7,50	5,98	1,04	21,54	6,94	21,55	5,26	8,88	5,26	1,03	21,04	6,84	21,46	4,94	7,45	4,93	1,01	

LWT °C		Outside air temperature, °C																				
		35							45													
		Qc			EER				q	Qc			EER				q					
kW			kW/kW				l/s	kW			kW/kW				l/s							
Nom Min Max			Nom Min Max				Nom	Nom Min Max			Nom Min Max				Nom							
30RQV 17	5	13,97	2,91	14,52	2,89	2,19	2,82	0,666	11,99	3,87	12,01	2,25	1,38	2,25	0,57							
30RQV 17	7	14,88	3,13	15,45	3,00	2,36	2,93	0,71	12,80	4,14	12,82	2,35	1,45	2,35	0,61							
30RQV 17	10	16,26	3,48	16,88	3,20	2,64	3,10	0,778	14,03	4,55	14,05	2,50	1,57	2,50	0,67							
30RQV 17	15	18,82	4,11	19,51	3,51	3,23	3,39	0,901	16,30	5,30	16,33	2,75	1,80	2,75	0,78							
30RQV 17	18	19,83	4,52	21,17	3,87	3,67	3,65	0,95	18,10	5,79	18,13	2,99	1,95	2,99	0,87							

Legend

LWT Leaving water temperature, °C
 Qc Cooling capacity, kW
 Nom Nominal
 Min Minimum
 Max Maximum
 EER Energy Efficiency Ratio, kW/kW
 q Evaporator water flow rate, l/s

Application data

Standard units, refrigerant: R-410A
 Evaporator entering/leaving water temperature difference: 5 K or minimum mass flow rate
 Evaporator fluid: water
 Fouling factor: 0 m² K/W
 Performances in accordance with EN 14511-3:2011.

Cooling capacities

30RQV 21 Unit

LWT °C		Outside air temperature, °C																					
		10							15							25							
		Qc			EER				q	Qc			EER				q	Qc			EER		
kW			kW/kW				l/s	kW			kW/kW				l/s	kW			kW/kW				l/s
Nom Min Max			Nom Min Max				Nom	Nom Min Max			Nom Min Max				Nom	Nom Min Max			Nom Min Max				Nom
30RQV 21	5	20,47	14,08	23,95	4,73	4,63	3,68	0,98	20,02	12,51	24,01	4,38	3,12	3,69	0,96	19,50	13,54	23,31	3,87	4,06	3,30	0,93	
30RQV 21	7	21,57	14,90	25,83	4,83	4,83	4,02	1,03	21,12	13,24	25,69	4,49	3,26	3,93	1,01	20,65	14,38	24,63	4,02	4,27	3,40	0,99	
30RQV 21	10	23,27	16,18	28,40	4,95	5,13	4,35	1,11	22,83	7,91	28,12	4,64	4,60	4,19	1,09	22,45	8,23	26,69	4,23	4,22	3,53	1,07	
30RQV 21	15	26,91	18,43	32,59	5,56	5,63	4,72	1,29	26,75	9,30	32,59	5,40	5,76	4,65	1,28	25,65	9,60	30,32	4,59	4,99	3,74	1,23	
30RQV 21	18	28,87	19,85	35,49	5,67	5,92	5,01	1,38	29,16	9,71	35,50	5,79	5,30	4,92	1,40	27,70	10,52	32,63	4,79	5,57	3,85	1,33	

LWT °C		Outside air temperature, °C																				
		35							45													
		Qc			EER				q	Qc			EER				q					
kW			kW/kW				l/s	kW			kW/kW				l/s							
Nom Min Max			Nom Min Max				Nom	Nom Min Max			Nom Min Max				Nom							
30RQV 21	5	17,70	8,14	21,82	2,96	3,14	2,57	0,84	14,86	6,37	16,08	2,25	2,21	2,22	0,71							
30RQV 21	7	18,58	8,67	23,08	3,10	3,33	2,65	0,89	15,79	6,79	17,07	2,34	2,33	2,30	0,75							
30RQV 21	10	20,43	9,50	25,03	3,09	3,42	2,77	0,98	17,21	7,45	18,60	2,47	2,51	2,43	0,82							
30RQV 21	15	23,40	11,00	28,49	3,36	3,91	2,95	1,12	19,76	8,62	21,34	2,70	2,83	2,65	0,95							
30RQV 21	18	25,81	11,97	30,67	3,80	4,24	3,05	1,24	21,38	9,38	23,08	2,83	3,03	2,77	1,02							

Legend

LWT Leaving water temperature, °C
 Qc Cooling capacity, kW
 Nom Nominal
 Min Minimum
 Max Maximum
 EER Energy Efficiency Ratio, kW/kW
 q Evaporator water flow rate, l/s

Application data

Standard units, refrigerant: R-410A
 Evaporator entering/leaving water temperature difference: 5 K or minimum mass flow rate
 Evaporator fluid: water
 Fouling factor: 0 m² K/W
 Performances in accordance with EN 14511-3:2011.

Heating capacities in accordance with EN14511-3 : 2013



30RQV 17 Unit

LWT °C		Outside air temperature, °C																				
		10 (9)							7 (6)							2 (1)						
		Qh			COP				q	Qh			COP				q	Qh			COP	
kW			kW/kW				l/s	kW			kW/kW				l/s	kW			kW/kW			l/s
Nom Min Max			Nom Min Max				Nom	Nom Min Max			Nom Min Max				Nom	Nom Min Max			Nom Min Max			Nom
30RQV 17	35	17,27	3,73	25,82	4,13	5,50	3,40	0,87	17,14	3,35	21,77	4,10	3,93	3,08	0,83	12,72	5,50	18,77	3,05	3,22	2,48	0,72
30RQV 17	45	16,25	4,95	25,47	3,33	3,88	2,83	0,82	16,16	4,47	20,44	3,40	2,87	2,51	0,78	12,03	5,17	18,01	2,50	3,02	2,04	0,68
30RQV 17	55	15,35	4,67	18,64	2,75	2,89	2,75	0,78	15,27	4,21	18,10	2,69	2,17	2,68	0,74	11,43	4,30	13,20	2,10	2,41	1,95	0,65
30RQV 17	60	14,69	4,65	15,66	2,49	2,60	2,44	0,74	14,74	3,87	15,30	2,58	1,80	2,57	0,72	11,07	4,16	11,37	1,92	2,17	1,90	0,63

LWT °C		Outside air temperature, °C																				
		-7 (-8)							-10 (-11)							-15 (-16)						
		Qh			COP				q	Qh			COP				q	Qh			COP	q
kW			kW/kW				l/s	kW			kW/kW				l/s	kW			kW/kW	l/s		
Nom Min Max			Nom Min Max				Nom	Nom Min Max			Nom Min Max				Nom	Nom Min Max			Nom Min Max	Nom		
30RQV 17	35	7,27	2,41	10,50	2,34	2,71	2,06	0,57	6,70	2,42	6,83	2,22	2,53	2,19	0,52	5,18	2,62	5,15	2,05	2,29	2,03	0,45
30RQV 17	45	6,91	2,29	10,10	1,96	2,20	1,71	0,54	6,42	2,86	6,60	1,87	2,08	1,85	0,50	4,90	2,46	4,93	1,71	1,88	1,71	0,45
30RQV 17	55	7,15	2,17	8,45	1,87	1,82	1,79	0,52	6,62	2,90	6,80	1,78	1,72	1,77	0,48	-	-	-	-	-	-	-
30RQV 17	60	6,95	2,15	7,06	1,72	1,70	1,69	0,50	6,45	2,93	6,58	1,65	1,63	1,63	0,47	-	-	-	-	-	-	-

LWT °C		Outside air temperature, °C						
		-20 (-21)						
		Qh			COP			
kW			kW/kW				l/s	
Nom Min Max			Nom Min Max				Nom	
30RQV 17	35	4,41	2,20	4,44	1,84	2,04	1,84	0,45
30RQV 17	45	4,23	2,13	4,26	1,57	1,73	1,57	0,45
30RQV 17	55	-	-	-	-	-	-	-
30RQV 17	60	-	-	-	-	-	-	-

Legend

LWT	Leaving water temperature, °C
Qh	Heating capacity, kW
Nom	Nominal
Min	Minimum
Max	Maximum
COP	Coefficient Of Performance, kW/kW
q	Condenser water flow rate, l/s

Application data

Standard units, refrigerant: R-410A
 Condenser entering/leaving water temperature difference: 5 K or minimum mass flow rate
 Condenser fluid: water
 Fouling factor: 0 m² K/W

Performances in accordance with EN 14511-3:2011.

Heating capacities

30RQV 21 Unit

		Outside air temperature, °C																				
		10 (9)							7 (6)							2 (1)						
		Qh			COP			q	Qh			COP			q	Qh			COP			q
LWT	°C	kW			kW/kW			l/s	kW			kW/kW			l/s	kW			kW/kW			l/s
		Nom	Min	Max	Nom	Min	Max	Nom	Nom	Min	Max	Nom	Min	Max	Nom	Nom	Min	Max	Nom	Min	Max	Nom
30RQV 21	35	22,88	8,78	32,72	4,48	3,80	3,62	1,09	21,10	7,56	22,17	4,10	4,37	2,94	1,01	15,62	7,27	19,91	2,90	3,08	2,47	0,90
30RQV 21	45	21,71	7,78	31,49	3,59	2,86	2,99	1,04	19,97	6,78	21,55	3,30	3,37	2,45	0,97	14,83	6,84	18,93	2,34	2,41	2,03	0,86
30RQV 21	55	20,47	7,24	24,92	2,92	2,21	2,73	0,99	19,07	6,31	23,24	2,69	2,63	2,53	0,92	13,70	6,37	17,02	1,90	1,91	1,83	0,79

		Outside air temperature, °C																				
		-7 (-8)							-10 (-11)							-15 (-16)						
		Qh			COP			q	Qh			COP			q	Qh			COP			q
LWT	°C	kW			kW/kW			l/s	kW			kW/kW			l/s	kW			kW/kW			l/s
		Nom	Min	Max	Nom	Min	Max	Nom	Nom	Min	Max	Nom	Min	Max	Nom	Nom	Min	Max	Nom	Min	Max	Nom
30RQV 21	35	10,39	6,50	15,31	2,51	2,74	2,22	0,69	9,56	5,82	10,30	2,37	2,55	2,35	0,64	7,57	4,94	7,58	2,15	2,25	2,15	0,58
30RQV 21	45	9,74	7,56	14,70	1,99	2,02	1,80	0,66	8,94	6,88	9,66	1,89	1,89	1,87	0,61	7,00	5,80	7,01	1,71	1,68	1,71	0,58
30RQV 21	55	9,03	7,07	11,28	1,60	1,60	1,55	0,62	8,24	6,38	8,98	1,52	1,50	1,52	0,58	-	-	-	-	-	-	-

		Outside air temperature, °C							
		-20 (-21)							
		Qh			COP			q	
LWT	°C	kW			kW/kW			l/s	
		Nom	Min	Max	Nom	Min	Max	Nom	
30RQV 17	35	6,32	4,11	6,40	1,93	1,98	1,92	0,58	
30RQV 17	45	5,84	4,75	5,85	1,54	1,49	1,54	0,58	
30RQV 17	60	-	-	-	-	-	-	-	

Legend

LWT	Leaving water temperature, °C
Qh	Heating capacity, kW
Nom	Nominal
Min	Minimum
Max	Maximum
COP	Coefficient Of Performance, kW/kW
q	Condenser water flow rate, l/s

Application data

Standard units, refrigerant: R-410A
 Condenser entering/leaving water temperature difference: 5 K or minimum mass flow rate
 Condenser fluid: water
 Fouling factor: 0 m² K/W

Performances in accordance with EN 14511-3:2011.



Order No.: 10128, 07.2016. Supersedes 10128, 03.2016
Manufacturer reserves the right to change any product specifications without notice.



Quality and Environment
Management Systems
Approval

Manufactured by: Carrier SCS, Montluel, France
Printed in the European Union