



United Technologies

PRO-DIALOG

AQUASNAP™



www.eurovent-certification.com
www.certiflash.com



Quality
Management
Systems



30RB 008-015

Nominal cooling capacity 8-14 kW

The new generation of Aquasnap liquid chillers was designed for commercial applications such as the air conditioning of offices and hotels etc.

The new Aquasnap units integrate the latest technological innovations:

- ozone-friendly refrigerant R410A
- scroll or rotary compressors
- low-noise fans
- auto-adaptive microprocessor control

The Aquasnap units are available with or without integrated hydronic module depending on the application. Aquasnap units equipped with a hydronic module integrated into the unit chassis, limit installation to straightforward operations like connection of the power supply and the water supply and the return piping.

Features

Quiet operation

- Compressors
 - Low-noise scroll or rotary compressors with low vibration levels
 - The compressors are placed on anti-vibration mountings and maintenance-free.
- Air heat exchanger section
 - The latest-generation low-noise fans are now even quieter and do not generate intrusive low-frequency noise
 - Rigid fan installation for reduced start-up noise

Advanced technology and performance

- The air management system, consisting of the propeller fan, orifice and air discharge grille, guarantees minimised sound levels.
- Wide temperature operating range: Aquasnap units can operate efficiently in extreme temperature conditions. To suit the requirements of all applications, the new Aquasnap units can work at low-ambient conditions in cooling mode (down to -10°C and up to 46°C outside temperature).

New patented fan blade shape and grille profile with low pressure drop

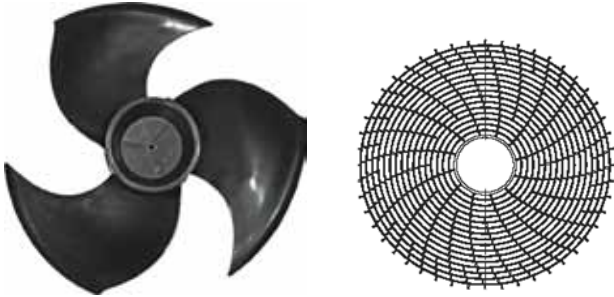

Fast and simple installation and service

- Easy access to all internal components: simply undo three screws to remove the complete front panel to access the refrigerant piping connections, control box and electrical connections, as well as the compressor and other key parts.
- Advanced circuit design and component selection has resulted in a compact unit with an exceptionally small footprint that is easy to transport even through narrow doors.
- Reduced operating weight and a handle on the unit panels to facilitate transport.
- 3 bar pressure relief valve as standard
- Internal expansion tank
- High-pressure refrigerant protection
- Water flow switch to ensure that the circuits operate with the correct water flow rate.
- Various power cable outlet options: pre-punched holes in the cabinet panels permit cable exit on the side, front or rear.
- An HMI graphic service interface can be used to monitor and set the unit operating parameters.
- All units are equipped with 1 inch gas MPT water connections.
- Option for an integrated hydronic module reduces space requirements and simplifies the installation. Only the power and the water supply and the return piping need to be connected.



- Specially shaped anchorage feet ensure correct and safe unit fixing to the foundation.

Economical operation

- Increased energy efficiency
 - The high energy efficiency of the Aquasnap units is the result of a long qualification and optimisation process.
 - Aquasnap units have Eurovent energy efficiency class A (size 008) or B (sizes 012 and 015)
- Reduced maintenance costs
 - Maintenance-free scroll or rotary compressors
 - Fast diagnosis of possible incidents and their history via the Pro-Dialog+ control
 - R410A refrigerant is easier to use than other refrigerant blends

Environmental care

- Ozone-friendly R410A refrigerant
 - Chlorine-free refrigerant of the HFC group with zero ozone depletion potential
 - Very efficient - gives an increased energy efficiency ratio (EER)
- Leak-tight refrigerant circuit
 - Brazed refrigerant connections for increased leak-tightness
 - Verification of pressure transducers and temperature sensors without transferring refrigerant charge
- The components of Aquasnap systems are free of any hazardous substances.
- The new packaging ensures high protection during transport and handling and is 100% recyclable.

Hydronic module

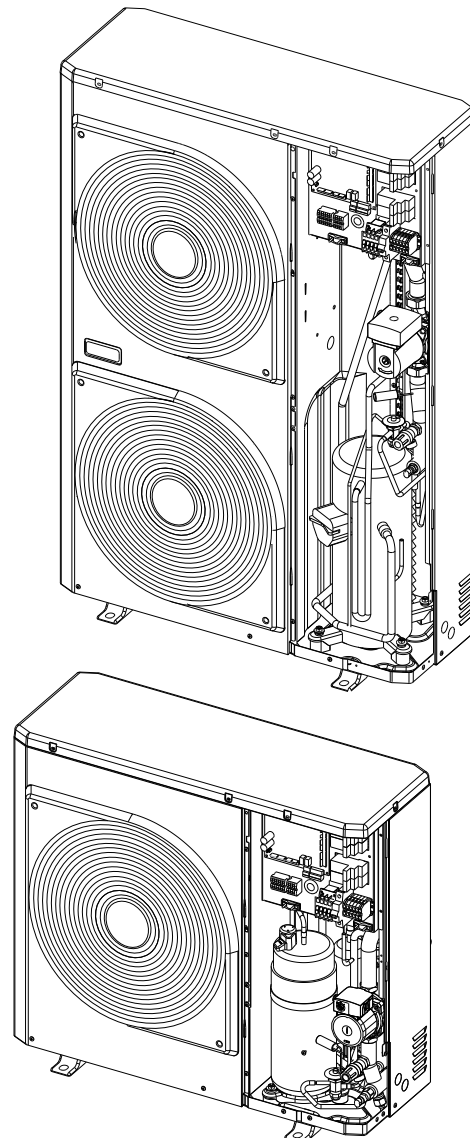

Superior reliability

- Auto-adaptive control
 - Control algorithm prevents excessive compressor cycling and permits reduction of the water quantity in the hydronic circuit (Carrier patent)
- Exceptional endurance tests
 - Corrosion resistance tests in salt mist in the laboratory
 - Accelerated ageing test on components that are submitted to continuous operation: compressor piping, fan supports
 - Transport simulation test in the laboratory on a vibrating table.
 - Packaging crash test to ensure that the units are adequately protected against accidental shocks.
- All units are tested at various stages on the production line for circuit leakage, electrical compliance, water and refrigerant pressures.
 - End-of-line test of all unit operating parameters.
 - Third-party testing and certification - all performances are certified by Eurovent and unit safety is certified by DEKRA.

Corrosion-resistant casing



User interfaces

- The Aquasnap can use the following user interfaces:
 - dry contacts
 - the Aquasnap Junior remote controller (option)

Pro-Dialog+ control

Pro-Dialog+ combines intelligence with operating simplicity. The control constantly monitors all machine parameters and precisely manages the operation of compressors, expansion devices, fans and of the water heat exchanger water pump for optimum energy efficiency.

- Energy management
 - Seven-day internal time schedule clock: permits unit on/off control and operation at a second set point
 - Set point reset based on the outside air temperature or the return water temperature or on the water heat exchanger delta T
 - Master/slave control of two units operating in parallel with operating time equalisation and automatic change-over in case of a unit fault.
 - Change-over based on the outside air temperature
- Integrated features
 - Night mode: capacity and fan speed limitation for reduced noise level

Type key

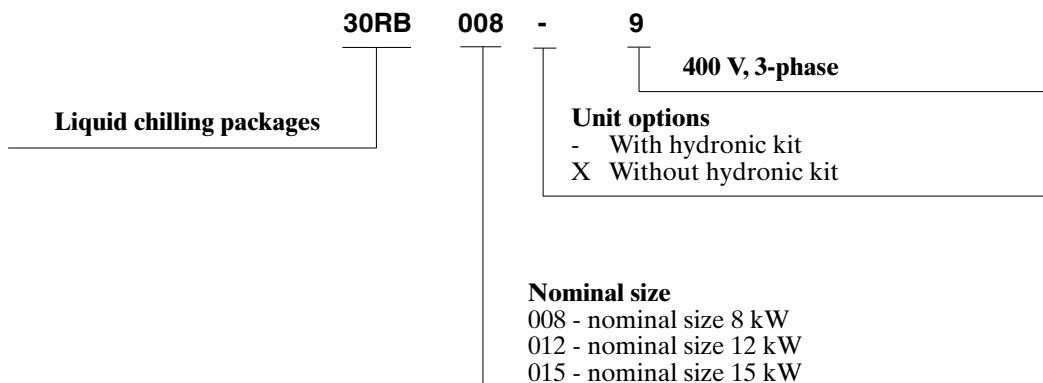

Option

Option	Description	Advantages	Use
Interface 30RAJ9002	Aquasnap Junior remote controller	ECO mode	All sizes

Hydronic module

The hydronic module reduces the installation time. The unit is factory-equipped with the main hydronic components required for the installation: screen filter, water pump, expansion tank, safety valve and pressure gauge.

The water heat exchanger and the hydronic module are protected against frost down to -10°C, using pump cycling.

The hydronic module is integrated into the unit without increasing its dimensions and saves the space normally used for the water pump.

Hydronic components

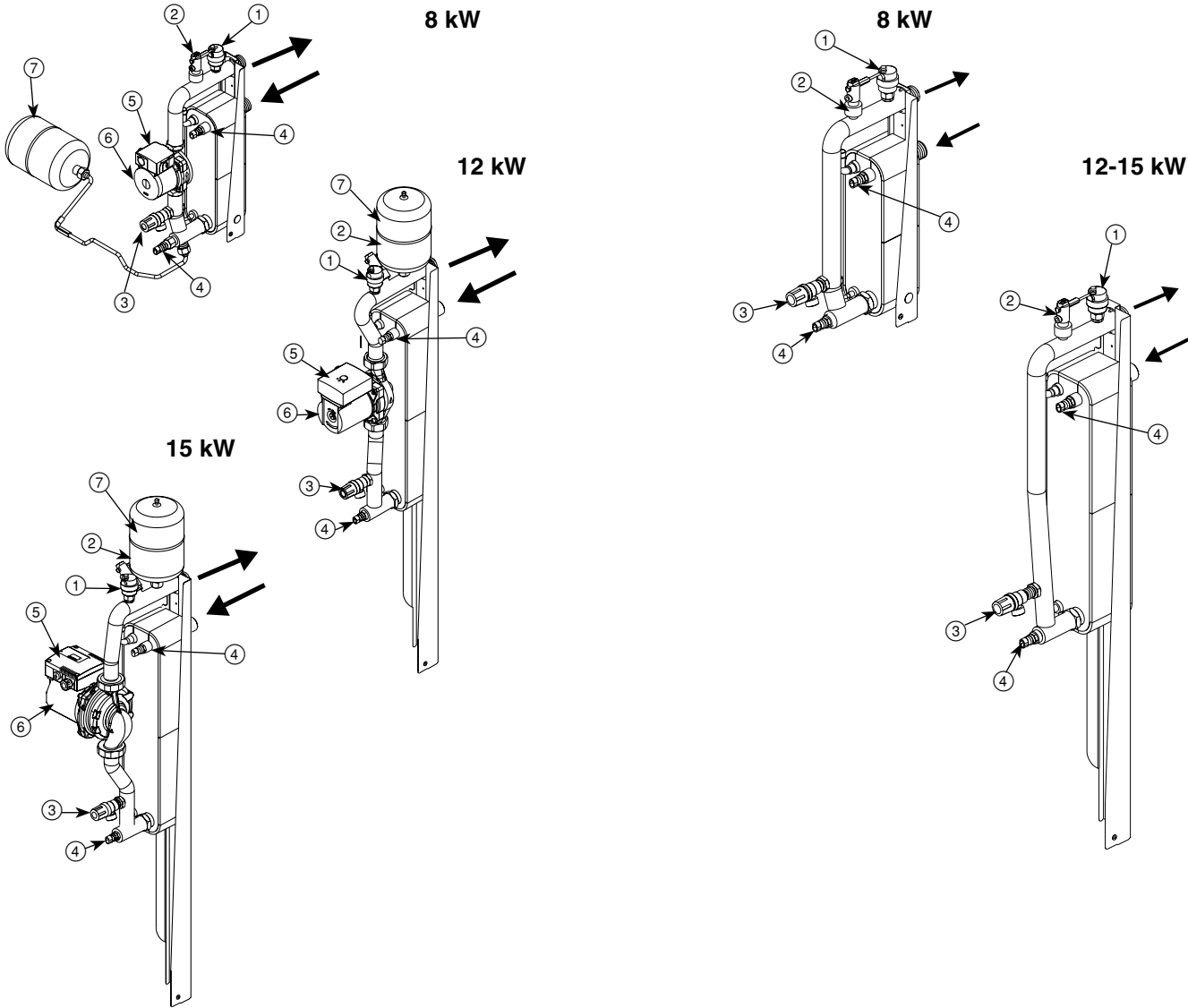

Legend

30RB__9

Integrated water circuit (with pump)

- 1 Automatic purge valve
- 2 Flow switch
- 3 Safety valve (1/2" outlet)
- 4 Temperature sensor
- 5 Circulation pump
- 6 Plug to unblock seized pump
- 7 Expansion tank

30RB__X9

Integrated water circuit (without pump)

- 1 Automatic valve with air vent
- 2 Flow switch
- 3 Safety valve (1/2" outlet)
- 4 Temperature sensor

Physical data

30RB		008	012	015
Air conditioning application as per EN14511-3:2011*				
Condition 1				
Nominal cooling capacity	kW	8.0	10.8	14.0
EER	kW/kW	3.10	2.93	2.91
Eurovent class, cooling		A	B	B
ESEER	kW/kW	3.30	3.24	3.09
Condition 2				
Nominal cooling capacity	kW	10.1	15.0	17.7
EER	kW/kW	3.70	3.65	3.43
Condition 3				
Nominal cooling capacity	kW	5.1	7.0	8.4
EER	kW/kW	2.24	1.95	1.90
Air conditioning application**				
Condition 1				
Nominal cooling capacity	kW	8.0	10.9	14.1
EER	kW/kW	3.17	3.01	3.00
Eurovent class, cooling		B	B	B
Condition 2				
Nominal cooling capacity	kW	10.2	15.1	17.9
EER	kW/kW	3.83	3.80	3.59
Condition 3				
Nominal cooling capacity	kW	5.1	7.0	8.5
EER	kW/kW	2.27	1.98	1.93
Operating weight (net)***				
Standard unit, with/without hydronic module	kg	75.5/73.3	114/108	116/110
Sound levels				
Sound power level****	dB(A)	68	70	71
Sound pressure level†	dB(A)	48	50	51
Dimensions				
Length x depth x height	mm	908 x 350 x 821	908 x 350 x 1363	908 x 350 x 1363
Compressor				
Expansion valve		One hermetic rotary compressor	One hermetic scroll compressor	One hermetic scroll compressor
Thermostatic expansion valve (TXV)				
Refrigerant charge R-410A				
	kg	2.15	2.63	3.18
Control				
Pro-Dialog+				
Fans				
Number/diameter	mm	1/495	2/495	2/495
Number of blades		3	3	3
Water heat exchanger				
Plate heat exchanger				
No. of plates		48	36	36
Design pressure	bar	45	45	45
Test pressure	bar	69	69	69
Air heat exchanger				
Copper tubes and aluminium fins				
Outside pipe diameter	mm	7	7	7
Number of rows		3	2	2
Number of pipes per row		36	60	60
Fin spacing	mm	1.41	1.41	1.41
Hydronic circuit				
Net water volume	l	1.0	2.3	2.3
Expansion tank capacity	l	2	2	2
Maximum water-side operating pressure	kPa	300	300	300
Water pressure drop, 30RBX version	kPa	15	21	33
Available static pressure, 30RB- version	kPa	34	53	70
Power input	kW	0.115	0.200	0.290
Nominal operating current drawn	A	0.45	0.70	1.30
Water connections, inlet/outlet (MPT gas)	in	1	1	1

* Eurovent-certified performances in accordance with standard EN14511-3:2011.

Condition 1: Cooling mode conditions: evaporator water entering/leaving temperature 12°C/7°C, outside air temperature 35°C, evaporator fouling factor 0 m2 K/W.

Condition 2: Cooling mode conditions: evaporator water entering/leaving temperature 23°C/18°C, outside air temperature 35°C, evaporator fouling factor 0 m2 K/W.

Condition 3: Cooling mode conditions: evaporator water entering/leaving temperature 0°C/-5°C, outside air temperature 35°C, evaporator fouling factor 0 m2 K/W, with 20% ethylene glycol.

** Gross performances, not in accordance with EN14511-3:2011. These performances do not take into account the correction for the proportional heating capacity and power input generated by the water pump to overcome the internal pressure drop in the heat exchanger.

Condition 1: Cooling mode conditions: evaporator water entering/leaving temperature 12°C/7°C, outside air temperature 35°C, evaporator fouling factor 0 m2 K/W.

Condition 2: Cooling mode conditions: evaporator water entering/leaving temperature 23°C/18°C, outside air temperature 35°C, evaporator fouling factor 0 m2 K/W.

Condition 3: Cooling mode conditions: evaporator water entering/leaving temperature 0°C/-5°C, outside air temperature 35°C, evaporator fouling factor 0 m2 K/W, with 20% ethylene glycol.

*** Weight shown is a guideline only. To find out the unit refrigerant charge, please refer to the unit nameplate.

**** In accordance with ISO 3741 (10⁻¹² W). Based on the following conditions: evaporator entering/leaving water temperature 12°C/7°C, outside air temperature 35°C.

† For information: The sound pressure level is measured in a hemispheric field at 4 m distance from the unit.

Electrical data

30RB/RQ		008	012	015
Power circuit				
Nominal power supply	V-ph-Hz	400-3-50 + neutral		
Voltage range	V	376-424		
Control circuit supply				
24 V via internal transformer				
Maximum start-up current (Un)*	A	30	66	73
Unit power factor at nominal capacity**		0.88	0.84	0.85
Maximum operating power input**	kW	3.1	4.4	5.5
Nominal unit operating current draw***	A	4.5	6.3	9.1
Power fuse current (gL fuse)	A	10	16	20
Power supply cable section	mm ²	H07RN-F - 5 x 2.5 mm ²	H07RN-F - 5 x 2.5 mm ²	H07RN-F - 5 x 2.5 mm ²
Maximum pump current (external pump or water circulator)	A	2	2	2
Number of fan motor capacitors (5 µF/450 V)		1	2	2
Power supply cable section, remote controller	mm ²	H03VV-F - 7 x 0.5 mm ²	H03VV-F - 7 x 0.5 mm	H03VV-F - 7 x 0.5 mm

* Maximum instantaneous start-up current (locked rotor current of the compressor).

** Power input, compressors and fans, at the unit operating limits (saturated suction temperature 10°C, saturated condensing temperature 65°C) and nominal voltage of 400 V (data given on the unit nameplate).

*** Standardised Eurovent conditions: water heat exchanger entering/leaving water temperature 12°C/7°C, outside air temperature 35°C.

Part load performances

With the rapid increase in energy costs and the care about environmental impacts of electricity production, the power consumption of air conditioning equipment has become an important topic. The energy efficiency of a unit at full load is rarely representative of the actual performance of the units, as on average a unit works less than 5% of the time at full load.

The heat load of a building depends on many factors, such as the outside air temperature, the exposure to the sun and the building occupancy.

Consequently it is preferable to use the average energy efficiency, calculated at several operating points that are representative for the unit utilisation.

ESEER (in accordance with EUROVENT)

The ESEER (European seasonal energy efficiency ratio) permits evaluation of the average energy efficiency at part load, based on four operating conditions defined by Eurovent. The ESEER is the average value of energy efficiency ratios (EER) at different operating conditions, weighted by the operating time.

ESEER (European seasonal energy efficiency ratio)

Load %	Air temperature °C	Energy efficiency	Operating time %
100	35	EER ₁	3
75	30	EER ₂	33
50	25	EER ₃	41
25	20	EER ₄	23
ESEER = EER ₁ x 3% + EER ₂ x 33% + EER ₃ x 41% + EER ₄ x 23%			

Note: Constant leaving water temperature 7°C.

Part load performances

30RB 008-015

30RB		008	012	015
ESEER	kW/kW	3.30	3.24	3.09

ESEER Calculations according to standard performances (in accordance with EN14511-3:2011) and certified by Eurovent.

Sound spectrum

30RB/RQ		Octave bands, Hz							Sound power levels	
		125	250	500	1000	2000	4000	8000		
008	dB	71	70	65	64	57	55	49	dB(A)	68
012	dB	73	69	67	66	60	57	50	dB(A)	70
015	dB	76	71	68	66	61	61	55	dB(A)	71

Operating limits

Evaporator water flow rate

30RB	Flow rate, l/s		
	Minimum	Maximum*	Maximum**
008	0.12	0.24	0.38
012	0.12	0.52	0.52
015	0.12	0.88	0.62

* Maximum flow rate at an available pressure of 50 kPa (unit with hydronic module)

** Maximum flow rate at condition 1 - evaporator water entering/leaving temperature 12°C/7°C, outside air temperature 35°C.

Operating range

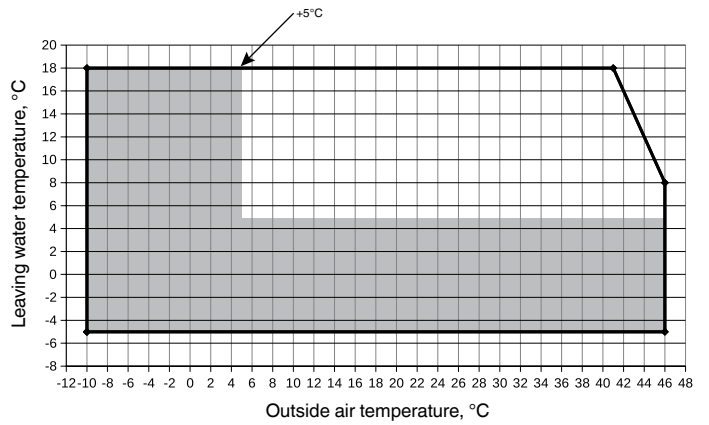

■ Operating range with anti-freeze solution and Pro-Dialog configuration.

Available static system pressure (units with hydronic module)

30RB 008-9

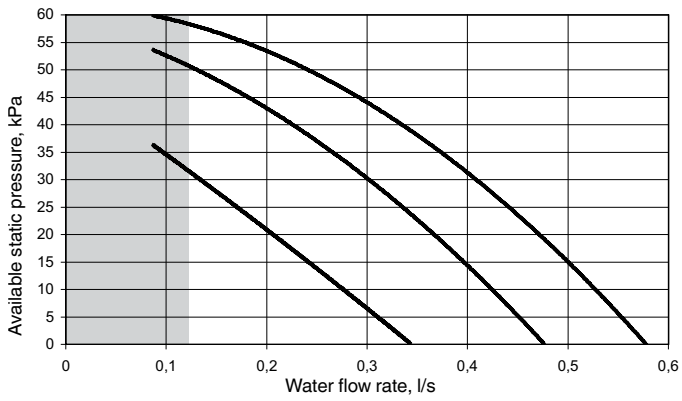

30RB 012-9

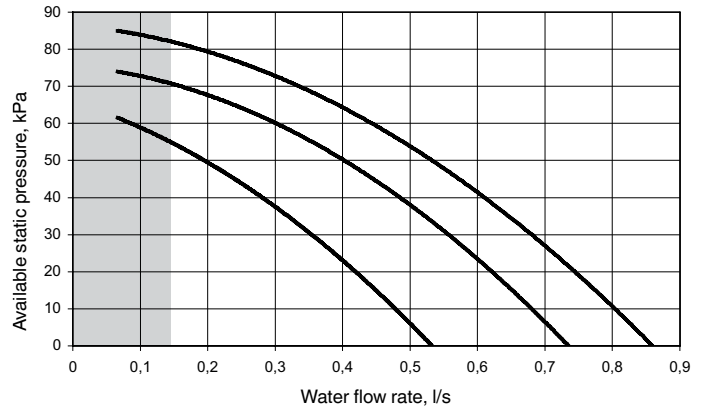

30RB 015-9

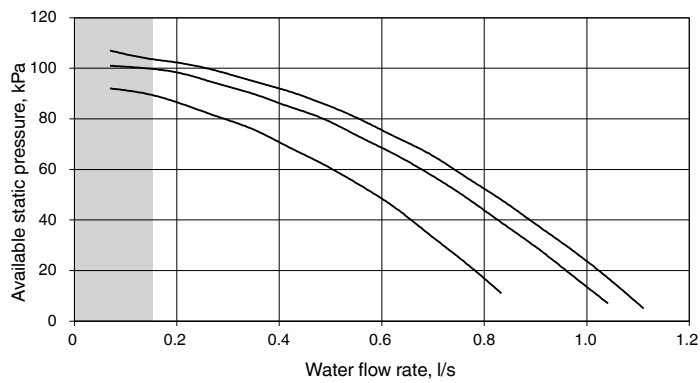

Pressure drop curves (units without hydronic module)

30RB 008X9

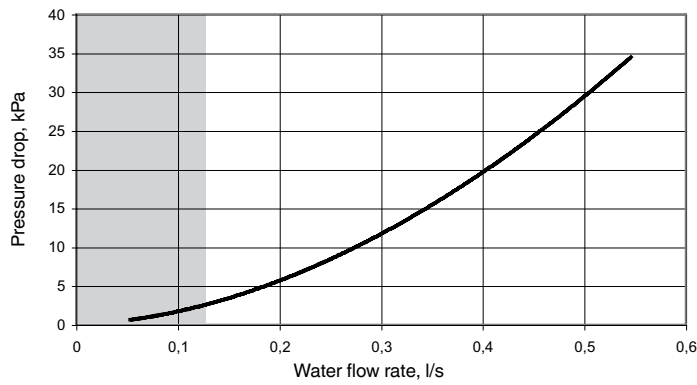

30RB 012X9/30RB 015X9

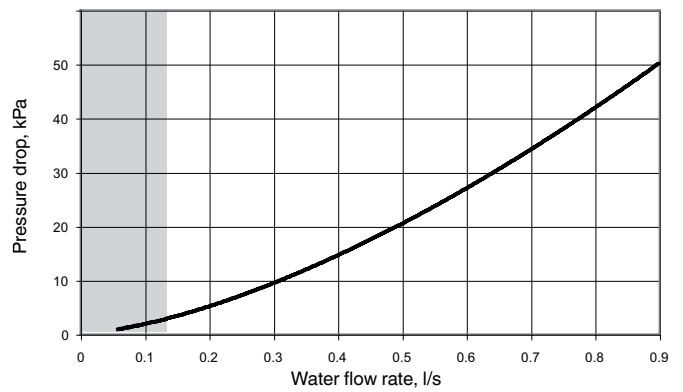

Dimensions, mm

30RB 012-015

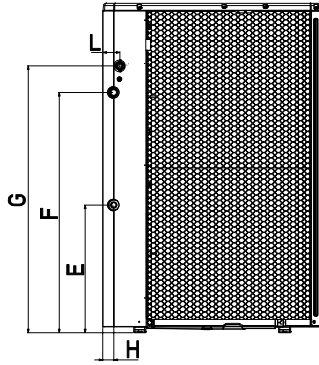
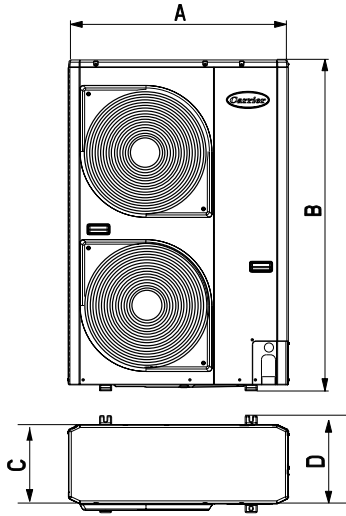

30RB 008

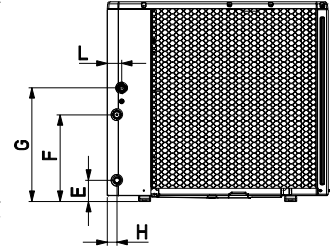
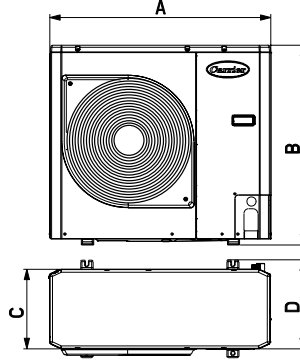

30RB	A	B	C	D	E	F	G	H	L	Net weight, kg	Gross weight, kg
008-9 with hydronic module	908	821	326	350	87	356	466	40	60	75.5	82.5
008X9 without hydronic module	908	821	326	350	87	356	466	40	60	73.5	80.5
012-9 with hydronic module	908	1363	326	350	529	995	1105	44	69	114	121
012X9 without hydronic module	908	1363	326	350	529	995	1105	44	69	108	114
015-9 with hydronic module	908	1363	326	350	529	995	1105	44	69	116	123
015X9 without hydronic module	908	1363	326	350	529	995	1105	44	69	110	116

Clearances, mm

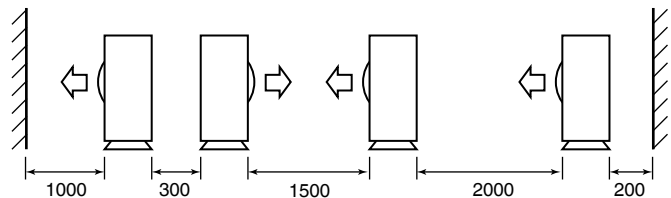
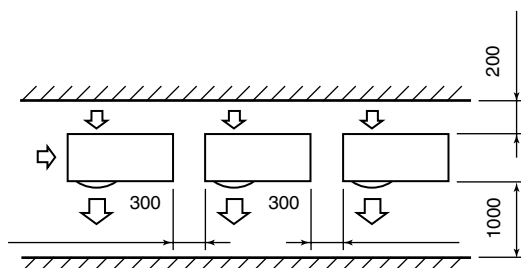
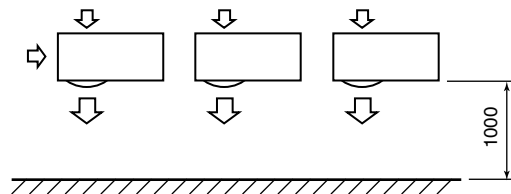
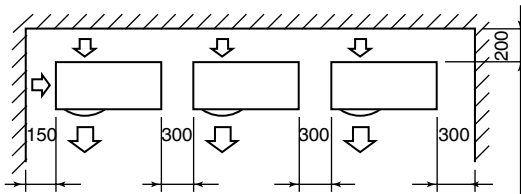
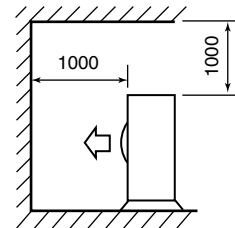
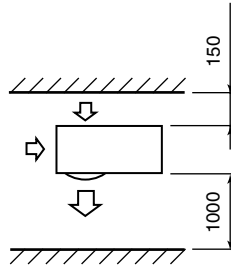
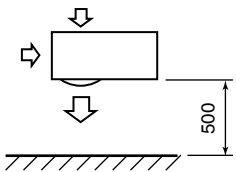
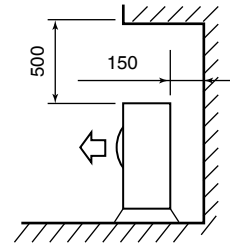
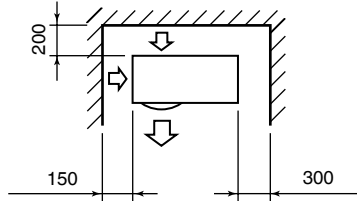
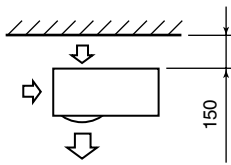

Recommended hydronic circuit installation

Typical water circuit diagram, 30RB units with integrated water pump

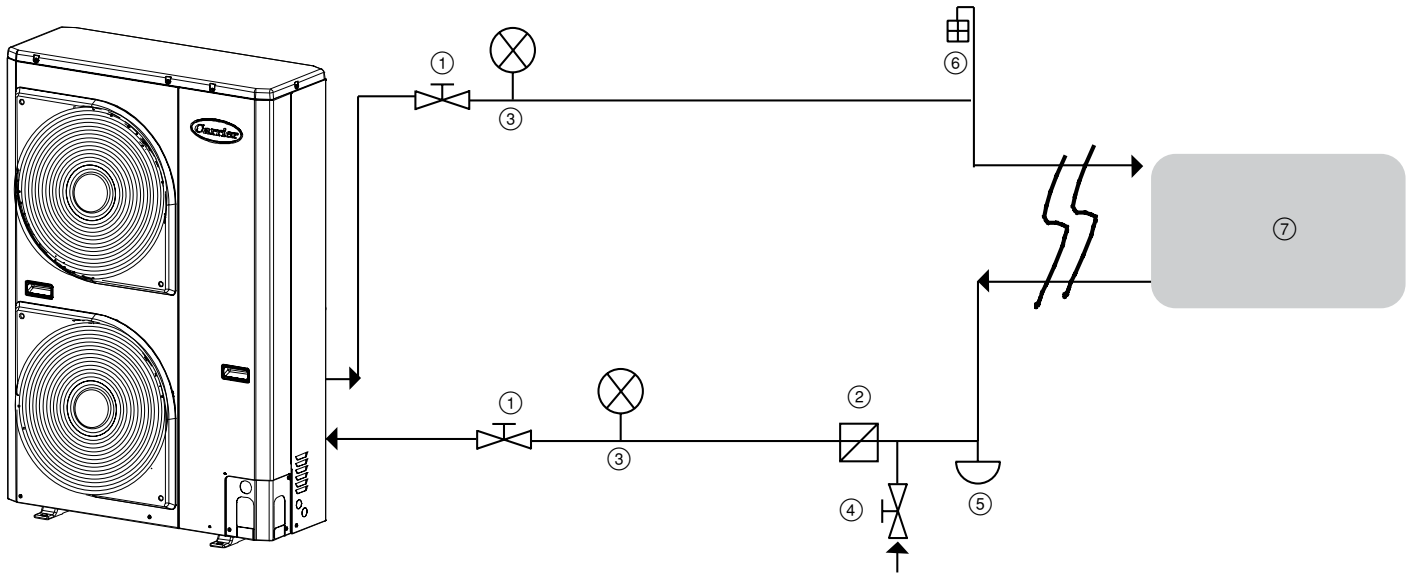

Legend

- 1 Shut-off valves
- 2 Line filter for water (10 mesh/inch)
- 3 Pressure gauges
- 4 Charge valve
- 5 System drain valve (at the lowest point of the circuit)
- 6 Air vent valve (in the highest part of the circuit)
- 7 Customer system

Typical water circuit diagram, 30RB units without integrated water pump

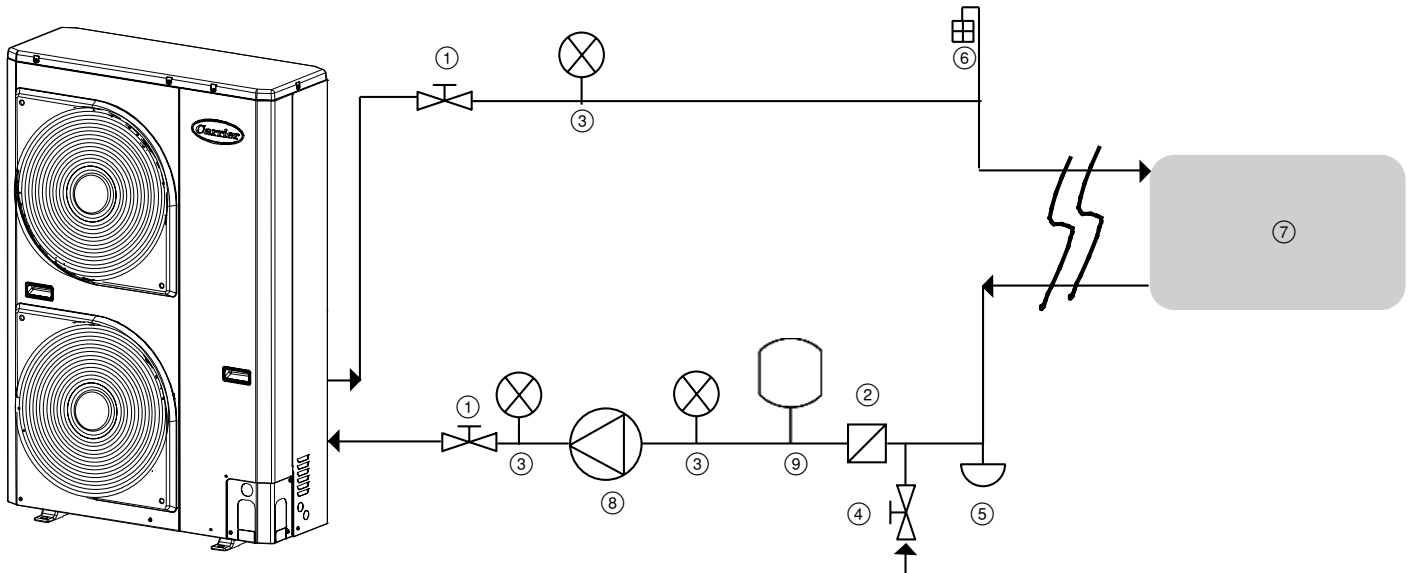

Legend

- 1 Shut-off valves
- 2 Line filter for water (10 mesh/inch)
- 3 Pressure gauges
- 4 Charge valve
- 5 System drain valve (at the lowest point of the circuit)
- 6 Air vent valve (in the highest part of the circuit)
- 7 Customer system
- 8 Water circulation pump
- 9 Expansion tank

Cooling capacities in accordance with EN14511-3 : 2011

LWT °C		Condenser entering air temperature, °C																																							
		-10				-5				0				5				10				15				20															
		Qc kW	EER kW/kW	q l/s	Δp kPa	Qc kW	EER kW/kW	q l/s	Δp kPa	Qc kW	EER kW/kW	q l/s	Δp kPa	Qc kW	EER kW/kW	q l/s	Δp kPa	Qc kW	EER kW/kW	q l/s	Δp kPa	Qc kW	EER kW/kW	q l/s	Δp kPa	Qc kW	EER kW/kW	q l/s	Δp kPa												
008 -5	012	015	008 0	012	015	008 5	012	015	008 7	012	015	008 10	012	015	008 15	012	015	008 18	012	015	008 -5	012	015	008 0	012	015	008 5	012	015	008 7	012	015	008 10	012	015	008 15	012	015	008 18	012	015

LWT °C		Condenser entering air temperature, °C																																							
		25				30				35				40				45				46																			
		Qc kW	EER kW/kW	q l/s	Δp kPa	Qc kW	EER kW/kW	q l/s	Δp kPa	Qc kW	EER kW/kW	q l/s	Δp kPa	Qc kW	EER kW/kW	q l/s	Δp kPa	Qc kW	EER kW/kW	q l/s	Δp kPa	Qc kW	EER kW/kW	q l/s	Δp kPa	Qc kW	EER kW/kW	q l/s	Δp kPa	Qc kW	EER kW/kW	q l/s	Δp kPa								
008 -5	012	015	008 0	012	015	008 5	012	015	008 7	012	015	008 10	012	015	008 15	012	015	008 18	012	015	008 -5	012	015	008 0	012	015	008 5	012	015	008 7	012	015	008 10	012	015	008 15	012	015	008 18	012	015

Legend
LWT Leaving water temperature, °C
Qc Cooling capacity, kW
EER Energy efficiency ratio, kW/kW
q Evaporator water flow rate, l/s
Δp Evaporator pressure drop, kPa

Application data
Standard units, refrigerant: R-410A
Evaporator entering/leaving water temperature difference: 5 K
Evaporator fluid: chilled water
Fouling factor: 0 m² K/W

Performances in accordance with EN14511-3:2011.

